

**Sensing range**  
5 / 8 mm

Inductive sensor

- Broad supply voltage range in AC and DC
- Robust brass housing, nickel-plated, with fine thread M18 x 1 mm
- Enclosure rating IP 67

Dimensional drawing

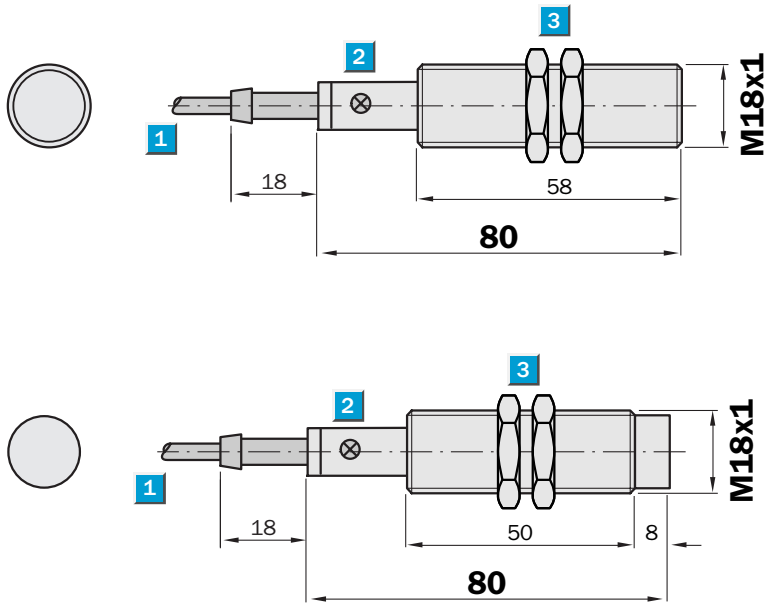

- 1 Connection
- 2 Display LED
- 3 Fastening nuts (2 x); width across 24, metal



Connection type

IM18-05BU0-ZU0  
IM18-08NU0-ZU0

IM18-05BUS-ZU0  
IM18-08NUS-ZU0

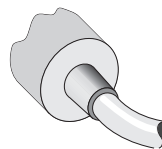
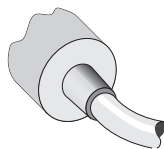

2 x 0.5 mm<sup>2</sup>

2 x 0.5 mm<sup>2</sup>

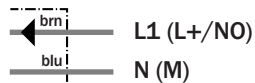
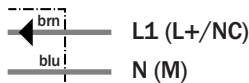

See chapter Accessories  
Mounting systems

Technical data		IM18-	05BUO -ZUO	05BUS -ZUO	08NUO -ZUO	08NUS -ZUO						
<b>Sensing range <math>S_n</math></b>	8 mm											
	5 mm											
<b>Electrical configuration</b>	AC/DC 2-wire											
<b>Supply voltage <math>V_s</math></b>	AC/DC 20 ... 250 V											
Voltage drop $V_d$ AC/DC	$\leq 6.5$ V / $\leq 6$ V											
<b>Continuous current <math>I_a</math></b>	$\leq 350$ mA AC (... + 50 °C)											
	$\leq 250$ mA AC (... + 80 °C)											
	$\leq 100$ mA DC											
Short duration current $I_k$	2.2 A (20 ms/0.5 Hz)											
Min. load current	5 mA											
Residual current	$\leq 2.5$ mA (250 V AC)											
	$\leq 1.3$ mA (110 V AC)											
	$\leq 0.8$ mA (24 V DC)											
Time delay before availability $t_v$	$\leq 8$ ms											
Hysteresis H, of $s_r$	1 ... 15 %											
Repeatability R	$\leq 10$ % ( $U_b$ and $T_a$ constant) <sup>1)</sup>											
Temperature drift, of $s_r$	$\pm 10$ %											
EMC	According to EN 60947-5-2											
<b>Output function</b>	Normally open											
	Normally closed											
<b>Installation</b>	Non-flush											
	Flush											
<b>Connection type</b>	Cable, PVC/PUR, 2 m											
Enclosure rating	IP 67 <sup>2)</sup>											
<b>VDE protection class</b>	<input type="checkbox"/>											
Max. switching frequency AC/DC	25 Hz / 100 Hz											
Dimensions	M18 x 1 <sup>3)</sup>											
<b>Power-up pulse suppression</b>	✓											
Shock/vibration stress	30 g, 11 ms/10 ... 55 Hz, 1 mm											
Ambient operating temperature $T_a$	-25 °C ... +80 °C											
Housing material	Brass nickel-plated, plastic											
Tightening torque	35 Nm											

<sup>1)</sup> of  $s_r$

<sup>2)</sup> according to EN 60529

<sup>3)</sup> thread diameter x pitch (mm)

#### Order information

Type	Order no.
IM18-05BUO-ZUO	7 902 123
IM18-05BUS-ZUO	7 902 122
IM18-08NUO-ZUO	7 902 125
IM18-08NUS-ZUO	7 902 124