

Multi-Cell LiPo Charging

Created by Bill Earl



Guide Contents

Guide Contents	2
Overview	3
Products Used:	4
Simple Balance Charger	5
Wiring:	5
Charging Mode:	6
Run Mode:	6
Fast Multi-Cell Charger	8
Wiring:	8
Charge Mode:	9
Run Mode:	9
High-Capacity Portable 5v Power	11

Overview



Lithium Polymer Batteries pack a lot of power in a small package. But they can be tricky to charge safely. The Adafruit LiPo Chargers all provide a charging cycle designed to safely charge 3.7v Lithium Polymer cells. But what if your project needs more than 3.7v?

Simply pumping more voltage into a multi-cell pack is risky. If the cells become unbalanced, some will end up with more of a charge than others. When put into service, the cells with the higher charge will end up working harder than the other cells. This will have an adverse effect on the capacity of the pack. Over time, it can result in damage and/or failure of one or more cells. And LiPo failures have been known to be quite spectacular.



This tutorial shows how to **safely** charge multiple cells while maintaining a balanced charge.



Products Used:

The examples in this tutorial are based on the Adafruit [USB / DC LiPo Charger](http://adafru.it/280) (<http://adafru.it/280>). But it will work equally well with our [USB LiPo Charger V1.2](http://adafru.it/259) (<http://adafru.it/259>).

The batteries shown in the photos are [2600 mAh cells](http://adafru.it/328) (<http://adafru.it/328>). But these examples will also work fine with our [1300 mAh](http://adafru.it/258) (<http://adafru.it/258>), [4400 mAh](http://adafru.it/354) (<http://adafru.it/354>) or [6600 mAh](http://adafru.it/353) (<http://adafru.it/353>) cells.

Simple Balance Charger



This charger assures that the cells are 'balanced' at all times by charging them in parallel. When the cells are connected in parallel, any difference in charge level is equalized and they appear as a single cell to the charger. At all times during the charge, the cells are at equal charge levels.

This circuit will work with the [USB / DC LiPo Charger \(http://adafru.it/280\)](http://adafru.it/280) or the [USB LiPo Charger V1.2 \(http://adafru.it/259\)](http://adafru.it/259) .

Wiring:

To accomplish this, we must disconnect the cells from the load. We use a 3-pole double-throw switch to simultaneously disconnect the load, connect the charger and switch the cells from a series to a parallel configuration. Charger output can be taken from any of the battery terminals via soldered connection or a JST connector.

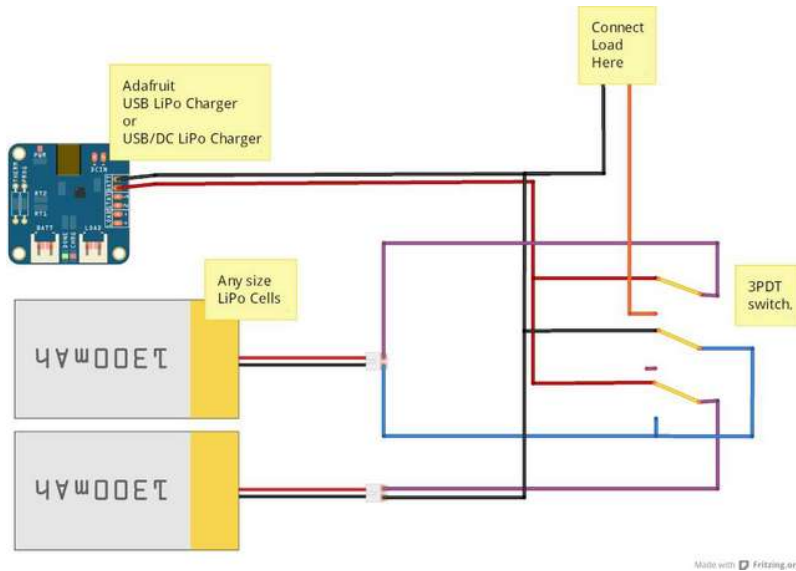

Charging Mode:

In charging mode, the cells are connected in parallel to the BATTERY IN terminals of the charger. The positive side of the Load output is disconnected during the charge.

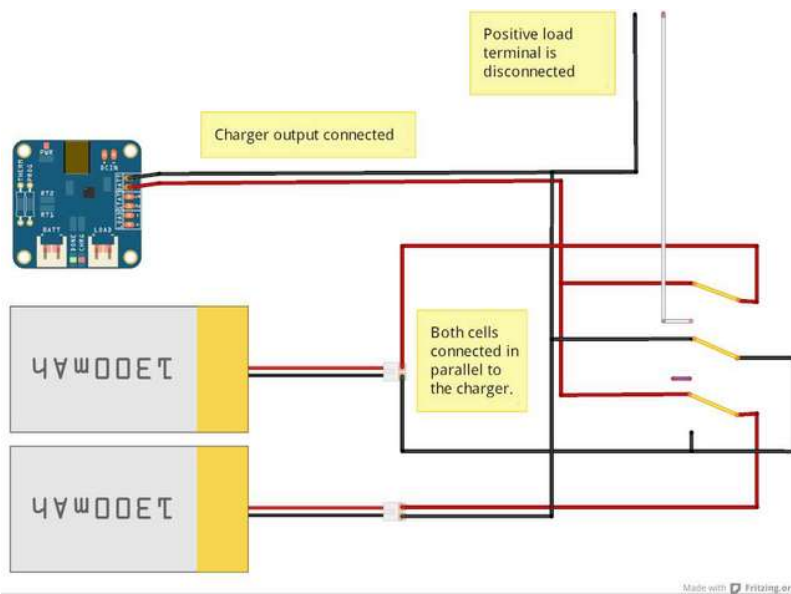

Run Mode:

In run mode, the positive connection to the BATTERY IN terminal is disconnected and the batteries are re-connected into a series configuration. The positive output is re-connected to supply 7.4v to the load.

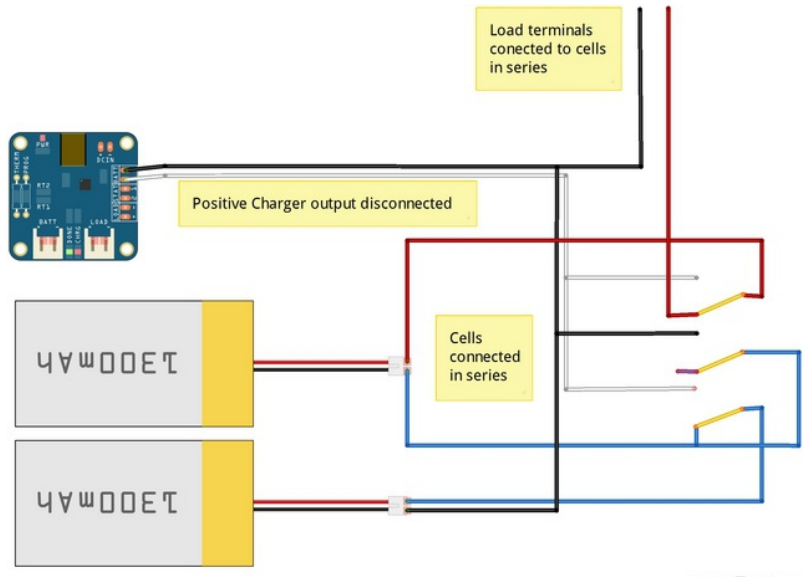

Made with  Fritzing.org

Fast Multi-Cell Charger



The limitation of the Simple Balance Charger is that the charger output is divided among multiple cells. The recharge time is limited by the maximum charge current of a single charger. To speed up the charge, we can use more than one charger.

Unlike the Simple Balance Charger, the cells are not directly connected while in "Charge" mode. This means that the cells may not be balanced through the entire charge cycle. With the Fast Multi-Cell Charger, it is best to wait until all cells are fully charged. This will assure that they are 'balanced' at 4.2v before switching to "Run" mode.

Wiring:

For the fast charger, we use one charge controller per LiPo cell. Again, we use a 3-pole double-throw switch to alternate between Charge and Run modes. The system is wired as shown in the diagram below:

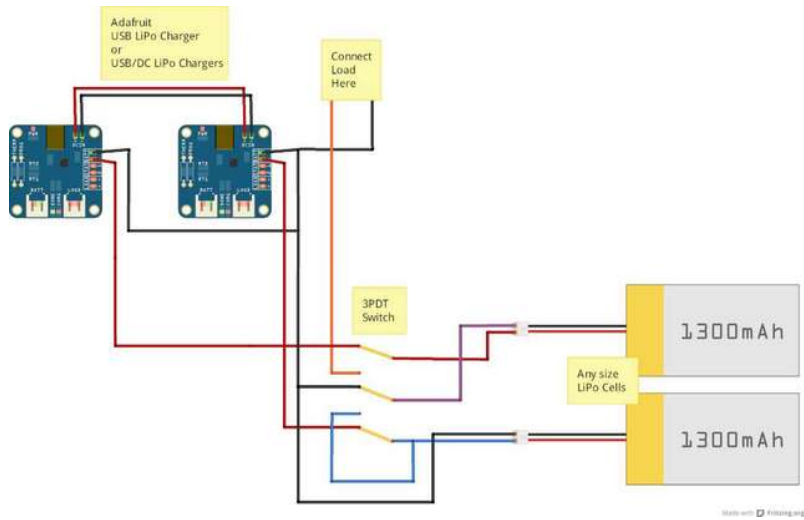

Charge Mode:

In Charge Mode, the cells are disconnected from each other and from the load. Each cell is connected to a dedicated charger.

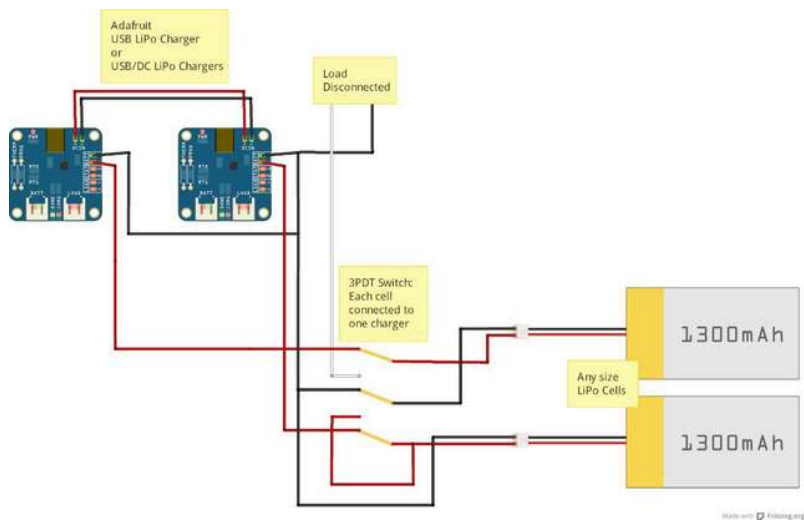

Run Mode:

In Run Mode, the cells are disconnected from the chargers. The cells are connected in a series configuration and connected to the load.

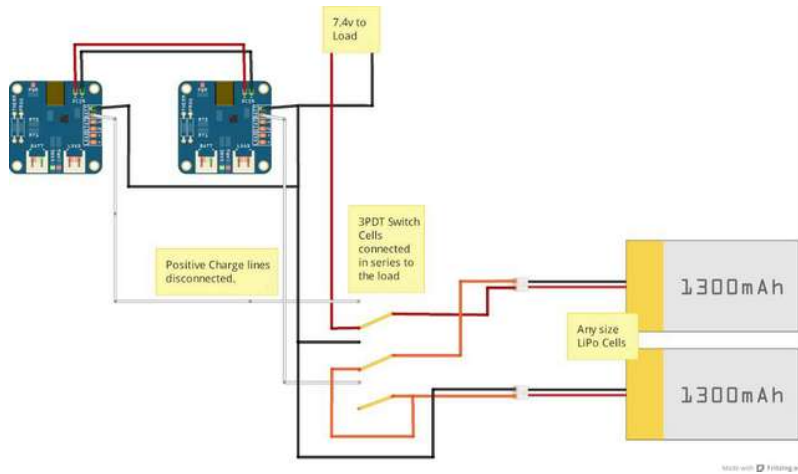

Since the cells are not guaranteed to be balanced during the fast-charge, it is best to wait until both cells are fully charged before switching to Run mode.

High-Capacity Portable 5v Power

A two cell LiPo pack will put out between 6 and 8.4v depending on its state of charge. This is too much for many applications. By adding a voltage regulator to the output, you can construct a 5v supply to power your projects.



Either charging circuit can be paired with one of our [high-efficiency DC/DC voltage converter](http://adafru.it/1065) (<http://adafru.it/1065>)s to make a portable high-capacity rechargeable 5v power pack for your Arduino, Raspberry Pi, or LED strip project. These "buck" converters operate at up to 94% efficiency - assuring that you get the longest possible run-time from your portable power system.

