

LM2438 Monolithic Triple 13.5 ns CRT Driver

General Description

The LM2438 is an integrated high voltage CRT driver circuit designed for use in color monitor applications. The IC contains three high input impedance, wide band amplifiers which directly drive the RGB cathodes of a CRT. Each channel has its gain internally set to -14 and can drive CRT capacitive loads as well as resistive loads present in other applications, limited only by the package's power dissipation.

The IC is packaged in an industry standard 9-lead TO-220 molded plastic power package. See Thermal Considerations section.

Features

- Well matched with LM1279 video preamp
- 0V to 5V input range
- Stable with 0–20 pF capacitive loads and inductive peaking networks
- Convenient TO-220 staggered lead package style
- Standard LM243X Family Pinout which is designed for easy PCB layout

Applications

- 1024 x 768 displays up to 60 Hz refresh
- Pixel clock frequencies up to 60 MHz
- Monitors using video blanking

Schematic and Connection Diagrams

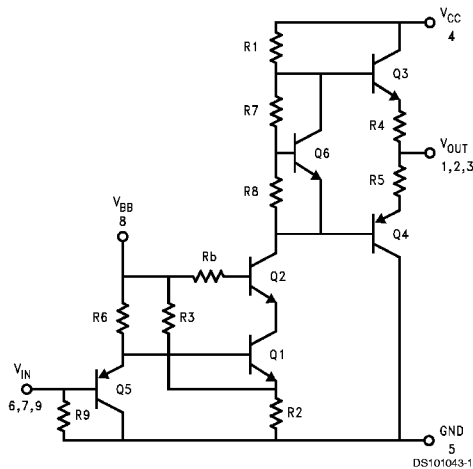
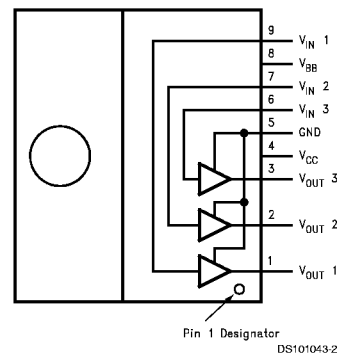

FIGURE 1. Simplified Schematic Diagram
(One Channel)



Note: Tab is at GND

Top View
Order Number LM2438T

Absolute Maximum Ratings (Notes 1, 3)

If Military/Aerospace specified devices are required, please contact the National Semiconductor Sales Office/Distributors for availability and specifications.

Supply Voltage (V_{CC})	+90V
Bias Voltage (V_{BB})	+16V
Input Voltage (V_{IN})	0V to 6V
Storage Temperature Range (T_{STG})	-65°C to +150°C

Lead Temperature (Soldering, <10 sec.)	300°C
ESD Tolerance, Human Body Model	2 kV
Machine Model	250V

Operating Ranges (Note 2)

V_{CC}	+60V to +85V
V_{BB}	+8V to +15V
V_{IN}	+0V to +5V
V_{OUT}	+15V to +75V
Case Temperature	-20°C to +100°C
Do not operate the part without a heat sink.	

Electrical Characteristics

(See Figure 2 for Test Circuit)

Unless otherwise noted: $V_{CC} = +80V$, $V_{BB} = +12V$, $C_L = 8$ pF, $T_C = 50^\circ C$;

DC Tests: $V_{IN} = 2.8 V_{DC}$;

AC Tests: Output = 40 V_{PP} (25V–65V) at 1 MHz.

Symbol	Parameter	Conditions	LM2438			Units
			Min	Typical	Max	
I_{CC}	Supply Current	All Three Channels, No AC Input Signal, No Output Load		18		mA
I_{BB}	Bias Current	All Three Channels		11		mA
V_{OUT}	DC Output Voltage	No AC Input Signal, $V_{IN} = 1.35V$	62	65	68	V_{DC}
A_V	DC Voltage Gain	No AC Input Signal	-12	-14	-16	
ΔA_V	Gain Matching	(Note 4), No AC Input Signal		1.0		dB
LE	Linearity Error	(Notes 4, 5), No AC Input Signal		8		%
t_R	Rise Time	(Note 6), 10% to 90%		13.9		ns
t_F	Fall Time	(Note 6), 90% to 10%		14.2		ns
OS	Overshoot	(Note 6)		5		%

Note 1: Absolute Maximum Ratings indicate limits beyond which damage to the device may occur.

Note 2: Operating ratings indicate conditions for which the device is functional, but do not guarantee specific performance limits. For guaranteed specifications and test conditions, see the Electrical Characteristics. The guaranteed specifications apply only for the test conditions listed. Some performance characteristics may change when the device is not operated under the listed test conditions.

Note 3: All voltages are measured with respect to GND, unless otherwise specified.

Note 4: Calculated value from Voltage Gain test on each channel.

Note 5: Linearity Error is the variation in dc gain from $V_{IN} = 1.0V$ to $V_{IN} = 4.6V$.

Note 6: Input from signal generator: $t_r, t_f < 1$ ns.

AC Test Circuit

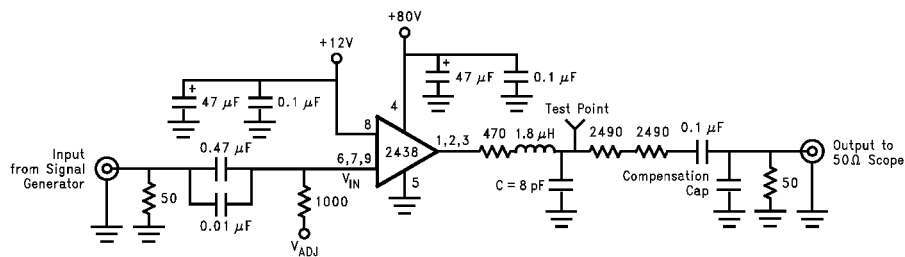

Note: 8 pF load includes parasitic capacitance.

FIGURE 2. Test Circuit (One Channel)

Figure 2 shows a typical test circuit for evaluation of the LM2438. This circuit is designed to allow testing of the LM2438 in a 50Ω environment without the use of an expensive FET probe. The two 2490Ω resistors form a 200:1 divider with the 50Ω resistor and the oscilloscope. A test point is included for easy use of an oscilloscope probe. The compensation capacitor is used to compensate the stray capacitance of the two 2490Ω resistors to achieve flat frequency response.

Typical Performance Characteristics ($V_{CC} = +80 V_{DC}$, $V_{BB} = +12 V_{DC}$, $C_L = 8 pF$, $V_{OUT} = 40 V_{PP}$ (25V–65V), Test Circuit - Figure 2 unless otherwise specified)

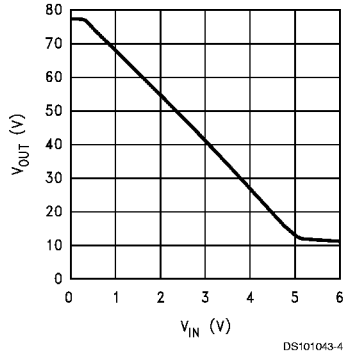

FIGURE 3. V_{OUT} vs V_{IN}

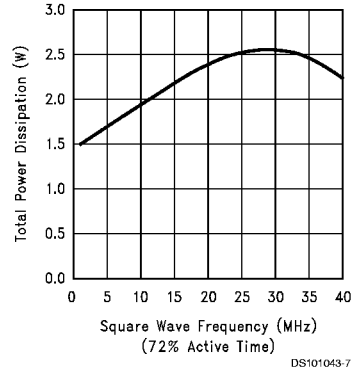

FIGURE 6. Power Dissipation vs Frequency

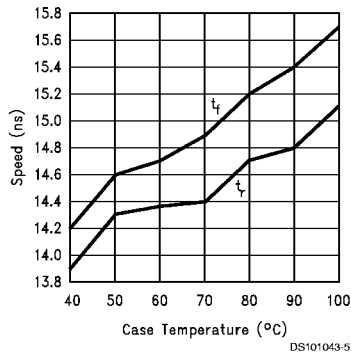

FIGURE 4. Speed vs Temp.

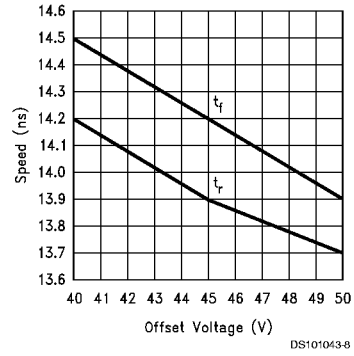

FIGURE 7. Speed vs Offset

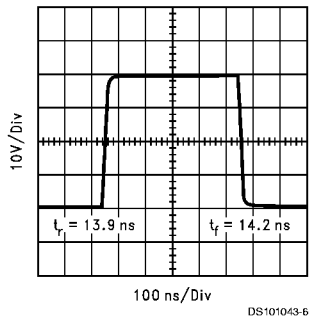

FIGURE 5. LM2438 Pulse Response

Typical Performance Characteristics ($V_{CC} = +80 V_{DC}$, $V_{BB} = +12 V_{DC}$, $C_L = 8 pF$, $V_{OUT} = 40 V_{PP}$
 (25V–65V), Test Circuit - Figure 2 unless otherwise specified) (Continued)

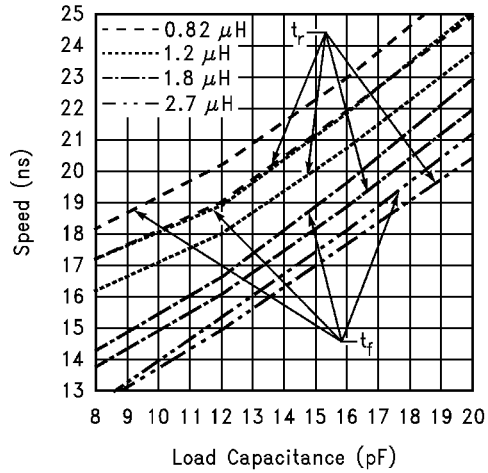

FIGURE 8. Speed vs Load Capacitance for Various Inductances

DS101043-9

Theory of Operation

The LM2438 is a high voltage monolithic three channel CRT driver suitable for high resolution display applications. The LM2438 operates with 80V and 12V power supplies. The part is housed in the industry standard 9-lead TO-220 molded plastic power package.

The circuit diagram of the LM2438 is shown in *Figure 1*. The PNP emitter follower, Q5, provides input buffering. Q1 and Q2 form a fixed gain cascode amplifier with resistors R1 and R2 setting the gain at -14 . Emitter followers Q3 and Q4 isolate the high output impedance of the cascode stage from the capacitance of the CRT cathode which decreases the sensitivity of the device to load capacitance. Q6 provides biasing to the output emitter follower stage to reduce cross-over distortion at low signal levels.

Figure 2 shows a typical test circuit for evaluation of the LM2438. This circuit is designed to allow testing of the LM2438 in a 50Ω environment without the use of an expensive FET probe. In this test circuit, the two $2.49\text{ k}\Omega$ resistors form a 200:1 wideband, low capacitance probe when connected to a 50Ω coaxial cable and a 50Ω load (such as a 50Ω oscilloscope input). The input signal from the generator is ac coupled to the base of Q5.

Application Hints

INTRODUCTION

National Semiconductor (NSC) is committed to provide application information that assists our customers in obtaining the best performance possible from our products. The following information is provided in order to support this commitment. The reader should be aware that the optimization of performance was done using a specific printed circuit board designed at NSC. Variations in performance can be realized due to physical changes in the printed circuit board and the application. Therefore, the designer should know that component value changes may be required in order to optimize performance in a given application. The values shown in this document can be used as a starting point for evaluation purposes. When working with high bandwidth circuits, good layout practices are also critical to achieving maximum performance.

IMPORTANT INFORMATION

The LM2438 performance is targeted for the XGA (1024 x 768, 60 Hz refresh) resolution market. The application circuits shown in this document to optimize performance and to protect against damage from CRT arcover are designed specifically for the LM2438. If another member of the LM243X family is used, please refer to its datasheet.

POWER SUPPLY BYPASS

Since the LM2438 is a wide bandwidth amplifier, proper power supply bypassing is critical for optimum performance. Improper power supply bypassing can result in large overshoot, ringing or oscillation. $0.1\ \mu\text{F}$ capacitors should be connected from the supply pins, V_{CC} and V_{BB} , to ground, as close to the LM2438 as is practical. Additionally, a $47\ \mu\text{F}$ or larger electrolytic capacitor should be connected from both supply pins to ground reasonably close to the LM2438.

ARC PROTECTION

During normal CRT operation, internal arcing may occasionally occur. Spark gaps, in the range of 200V, connected from the CRT cathodes to CRT ground will limit the maximum volt-

age, but to a value that is much higher than allowable on the LM2438. This fast, high voltage, high energy pulse can damage the LM2438 output stage. The application circuit shown in *Figure 9* is designed to help clamp the voltage at the output of the LM2438 to a safe level. The clamp diodes, D1 and D2, should have a fast transient response, high peak current rating, low series impedance and low shunt capacitance. FDH400 or equivalent diodes are recommended. Do not use 1N4148 diodes for the clamp diodes. D1 and D2 should have short, low impedance connections to V_{CC} and ground respectively. The cathode of D1 should be located very close to a separately decoupled bypass capacitor (C3 in *Figure 9*). The ground connection of D2 and the decoupling capacitor should be very close to the LM2438 ground. This will significantly reduce the high frequency voltage transients that the LM2438 would be subjected to during an arcover condition. Resistor R2 limits the arcover current that is seen by the diodes while R1 limits the current into the LM2438 as well as the voltage stress at the outputs of the device. R2 should be a $\frac{1}{2}\text{W}$ solid carbon type resistor. R1 can be a $\frac{1}{4}\text{W}$ metal or carbon film type resistor. Having large value resistors for R1 and R2 would be desirable, but this has the effect of increasing rise and fall times. Inductor L1 is critical to reduce the initial high frequency voltage levels that the LM2438 would be subjected to. The inductor will not only help protect the device but it will also help minimize rise and fall times as well as minimize EMI. For proper arc protection, it is important to not omit any of the components shown in *Figure 9*.

Application Hints (Continued)

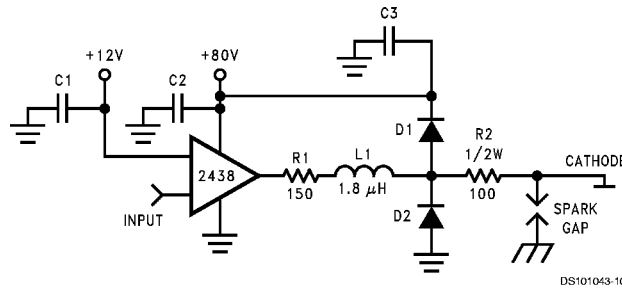

FIGURE 9. One Channel of the LM2438 with the Recommended Application Circuit

OPTIMIZING TRANSIENT RESPONSE

Referring to Figure 9, there are three components (R1, R2 and L1) that can be adjusted to optimize the transient response of the application circuit. Increasing the values of R1 and R2 will slow the circuit down while decreasing overshoot. Increasing the value of L1 will speed up the circuit as well as increase overshoot. It is very important to use inductors with very high self-resonant frequencies, preferably above 300 MHz. Ferrite core inductors from J.W. Miller Magnetics (part #78F1R8K) were used for optimizing the performance of the device in the NSC application board. The values shown in Figure 9 can be used as a good starting point for the evaluation of the LM2438. Using a variable resistor for R1 will simplify finding the value needed for optimum performance in a given application. Once the optimum value is determined the variable resistor can be replaced with a fixed value.

EFFECT OF LOAD CAPACITANCE

Figure 8 shows the effect of increased load capacitance on the speed of the device. This demonstrates the importance of knowing the load capacitance in the application. Figure 8 also shows the effect inductance has on the rise and fall times.

EFFECT OF OFFSET

Figure 7 shows the variation in rise and fall times when the output offset of the device is varied from 40 to 50 V_{DC}. The rise time shows a maximum variation relative to the center data point (45 V_{DC}) of about 2%. The fall time shows a variation of about 2% relative to the center data point.

THERMAL CONSIDERATIONS

Figure 4 shows the performance of the LM2438 in the test circuit shown in Figure 2 as a function of case temperature. The figure shows that the rise time of the LM2438 increases by approximately 5% as the case temperature increases from 50°C to 100°C. This corresponds to a speed degradation of 1% for every 10°C rise in case temperature. The fall time increases by approximately 7.5% as the case temperature increases from 50°C to 100°C. This corresponds to a speed degradation of 1.5% for every 10°C rise in case temperature.

Figure 6 shows the maximum power dissipation of the LM2438 vs. Frequency when all three channels of the device are driving an 8 pF load with a 40 V_{p-p} alternating one pixel on, one pixel off signal. The graph assumes a 72% active time (device operating at the specified frequency) which is typical in a monitor application. The other 28% of the time

the device is assumed to be sitting at the black level (65V in this case). This graph gives the designer the information needed to determine the heat sink requirement for his application. The designer should note that if the load capacitance is increased the AC component of the total power dissipation will also increase.

The LM2438 case temperature must be maintained below 100°C. If the maximum expected ambient temperature is 70°C and the maximum power dissipation is 2.6W (from Figure 6, 30 MHz bandwidth) then a maximum heat sink thermal resistance can be calculated:

$$R_{TH} = \frac{100^{\circ}\text{C} - 70^{\circ}\text{C}}{2.6\text{W}} = 11.5^{\circ}\text{C/W}$$

This example assumes a capacitive load of 8 pF and no resistive load.

TYPICAL APPLICATION

A typical application of the LM2438 is shown in Figure 11. Used in conjunction with an LM1279, a complete video channel from monitor input to CRT cathode can be achieved. Performance is ideal for 1024 x 768 resolution displays with pixel clock frequencies up to 60 MHz. Figure 11 is the schematic for the NSC demonstration board that can be used to evaluate the LM1279/2438 combination in a monitor.

PC BOARD LAYOUT CONSIDERATIONS

For optimum performance, an adequate ground plane, isolation between channels, good supply bypassing and minimizing unwanted feedback are necessary. Also, the length of the signal traces from the preamplifier to the LM2438 and from the LM2438 to the CRT cathode should be as short as possible. The following references are recommended:

Ott, Henry W., "Noise Reduction Techniques in Electronic Systems", John Wiley & Sons, New York, 1976.

"Video Amplifier Design for Computer Monitors", National Semiconductor Application Note 1013.

Pease, Robert A., "Troubleshooting Analog Circuits", Butterworth-Heinemann, 1991.

Because of its high small signal bandwidth, the part may oscillate in a monitor if feedback occurs around the video channel through the chassis wiring. To prevent this, leads to the video amplifier input circuit should be shielded, and input circuit wiring should be spaced as far as possible from output circuit wiring.

Application Hints (Continued)

NSC DEMONSTRATION BOARD

Figure 12 shows the routing and component placement on the NSC LM1279/2438 demonstration board. The schematic of the board is shown in Figure 11. This board provides a good example of a layout that can be used as a guide for future layouts. Note the location of the following components:

- C54, C56— V_{CC} bypass capacitor, located very close to pin 4 and ground pins
- C43, C44— V_{BB} bypass capacitors, located close to pin 8 and ground
- C53, C55—Additional V_{CC} bypass capacitors, near LM2438 and V_{CC} clamp diodes. Very important for arc protection.

The routing of the LM2438 outputs to the CRT is very critical to achieving optimum performance. Figure 13 shows the routing and component placement from pin 1 of the LM2438

to the red cathode. Note that the components are placed so that they almost line up from the output pin of the LM2438 to the red cathode pin of the CRT connector. This is done to minimize the length of the video path between these two components. Note also that D16, D17, R21 and D9 are placed to minimize the size of the video nodes that they are attached to. This minimizes parasitic capacitance in the video path and also enhances the effectiveness of the protection diodes. The anode of protection diode D17 is connected directly to a section of the the ground plane that has a short and direct path to the LM2438 ground pins. The cathode of D16 is connected to V_{CC} very close to decoupling capacitor C53 (see Figure 1.3) which is connected to the same section of the ground plane as D17. The diode placement and routing is very important for minimizing the voltage stress on the LM2438 during an arc-over event. Lastly, notice that S1 is placed very close to the red cathode and is tied directly to CRT ground.

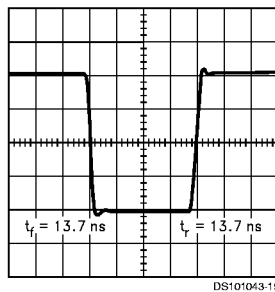
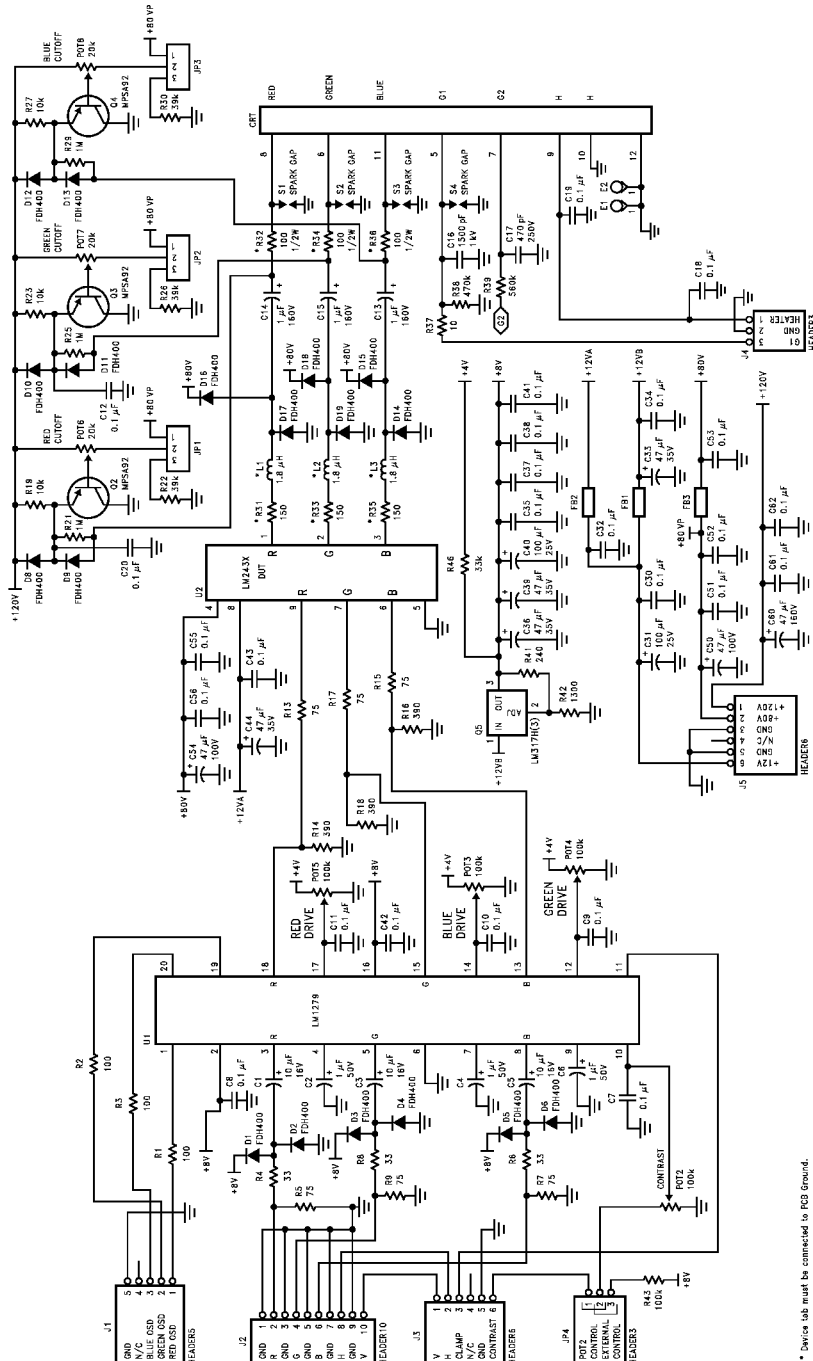

FIGURE 10. Waveform at Cathode with LM1279/243X Demo Board

Application Hints (Continued)



DS00043-11

FIGURE 11. LM1279/243X Demonstration Board Schematic

* Device tab must be connected to PCB Ground.

Application Hints (Continued)

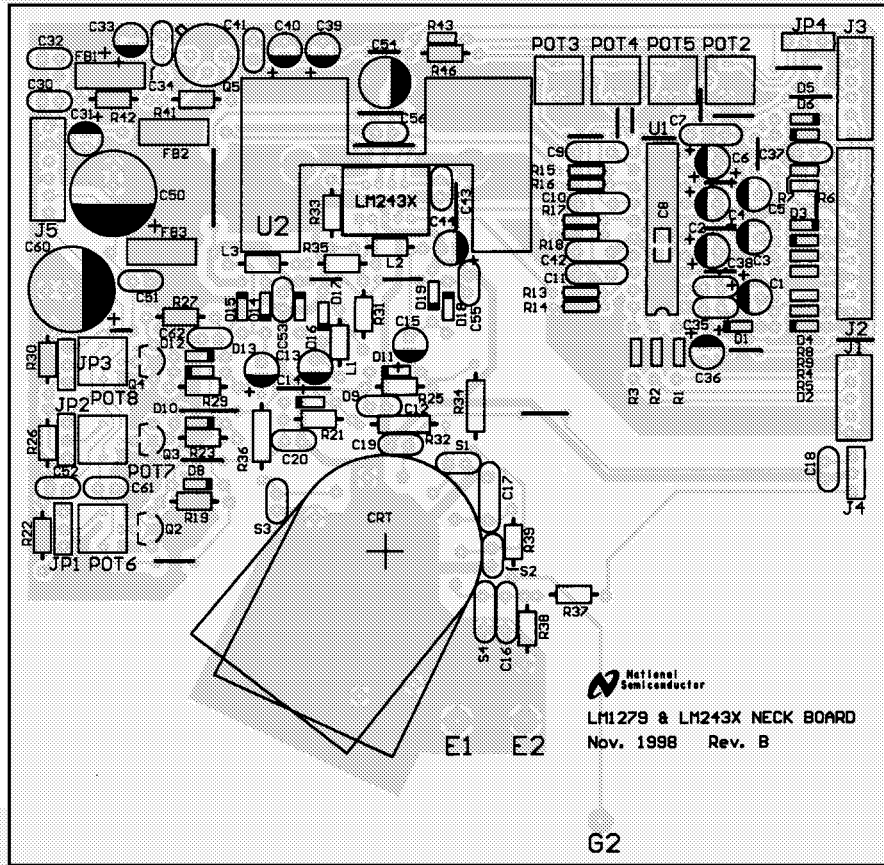
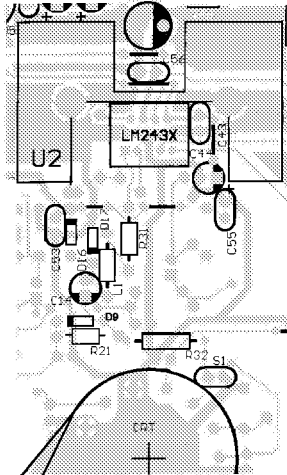

FIGURE 12. LM1279/243X Demo Board Layout

DS101043-13

Application Hints (Continued)



DS101043-14

FIGURE 13. Trace Routing and Component Placement for Red Channel Output

Physical Dimensions inches (millimeters) unless otherwise noted

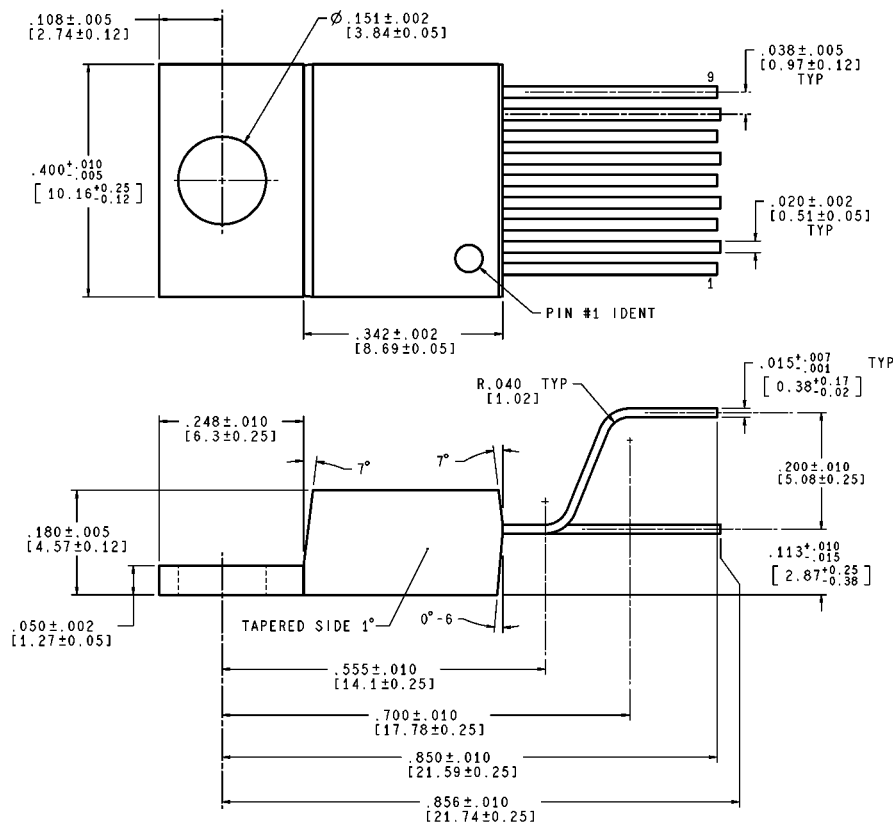

CONTROLLING DIMENSION IS INCH
VALUES IN [] ARE MILLIMETERS

TA09A (Rev C)

CONTROLLING DIMENSION IS INCH
VALUES IN [] ARE MILLIMETERS

NS Package Number TA09A
Order Number LM2438T

LIFE SUPPORT POLICY

NATIONAL'S PRODUCTS ARE NOT AUTHORIZED FOR USE AS CRITICAL COMPONENTS IN LIFE SUPPORT DEVICES OR SYSTEMS WITHOUT THE EXPRESS WRITTEN APPROVAL OF THE PRESIDENT AND GENERAL COUNSEL OF NATIONAL SEMICONDUCTOR CORPORATION. As used herein:

1. Life support devices or systems are devices or systems which, (a) are intended for surgical implant into the body, or (b) support or sustain life, and whose failure to perform when properly used in accordance with instructions for use provided in the labeling, can be reasonably expected to result in a significant injury to the user.
2. A critical component is any component of a life support device or system whose failure to perform can be reasonably expected to cause the failure of the life support device or system, or to affect its safety or effectiveness.

 National Semiconductor Corporation
Americas
Tel: 1-800-272-9959
Fax: 1-800-737-7018
Email: support@nsc.com
www.national.com

National Semiconductor Europe
Fax: +49 (0) 1 80-530 85 86
Email: europe.support@nsc.com
Deutsch Tel: +49 (0) 1 80-530 85 85
English Tel: +49 (0) 1 80-532 78 32
Français Tel: +49 (0) 1 80-532 93 58
Italiano Tel: +49 (0) 1 80-534 16 80

National Semiconductor Asia Pacific Customer Response Group
Tel: 65-2544466
Fax: 65-2504466
Email: sea.support@nsc.com

National Semiconductor Japan Ltd.
Tel: 81-3-5639-7560
Fax: 81-3-5639-7507