

PREPARED BY: <i>Yuji Asoh</i>	<b>SHARP</b>	SPEC No. LA1-05016
APPROVED BY: <i>Shiolenko Gabunski</i>		FILE No.
	MOBILE LIQUID CRYSTAL DISPLAY GROUP	ISSUED: May.30th.2005
	SHARP CORPORATION	PAGE : 19 pages
	<b>SPECIFICATION</b>	APPLICABLE GROUP
		MOBILE LIQUID CRYSTAL DISPLAY GROUP

DEVICE SPECIFICATION FOR  
**TFT-LCD module**  
 MODEL No. LQ057Q3DC12

CUSTOMER'S APPROVAL

DATE \_\_\_\_\_

BY \_\_\_\_\_

PRESENTED

BY *Hiroshi Hamada* \_\_\_\_\_

H. HAMADA  
 Department General manager  
 Engineering Department. 1  
 Mobile LCD Design Center. 1  
 Mobile Liquid Crystal Display Group  
**SHARP CORPORATION**



**NOTICE**

This publication is the proprietary of SHARP and is copyrighted, with all rights reserved. Under the copyright laws, no part of this publication may be reproduced or transmitted in any form or by any means, electronic or mechanical for any purpose, in whole or in part, without the express written permission of SHARP. Express written permission is also required before any use of this publication may be made by a third party.

The application circuit examples in this publication are provided to explain the representative applications of SHARP's devices and are not intended to guarantee any circuit design or permit any industrial property right or other rights to be executed. SHARP takes no responsibility for any problems related to any industrial property right or a third party resulting from the use of SHARP's devices, except for those resulting directly from device manufacturing processes.

In the absence of confirmation by device specification sheets, SHARP takes no responsibility for any defects that occur in equipment using any of SHARP's devices, shown in catalogs, data books, etc. Contact SHARP in order to obtain the latest device specification sheets before using any SHARP's device.

SHARP reserves the right to make changes in the specifications, characteristics, data, materials, structures and other contents described herein at any time without notice in order to improve design or reliability. Contact SHARP in order to obtain the latest specification sheets before using any SHARP's device. Manufacturing locations are also subject to change without notice.

Observe the following points when using any device in this publication. SHARP takes no responsibility for damage caused by improper use of the devices.

The devices in this publication are designed for general electronic equipment use.

The appropriate design measures should be taken to ensure reliability and safety when SHARP's devices are used for equipment such as:

- Transportation control and safety equipment (i.e., aircraft, trains, automobiles, etc.)
- Traffic signals • Gas leakage sensor breakers • Alarm equipment • Various safety devices etc.

SHARP's devices shall not be used for equipment that requires extremely high level of reliability, such as:

- Military and space applications      • Nuclear power control equipment
- Medical equipment for life support

Contact a SHARP representative, in advance, when intending to use SHARP's devices for any "specific" applications other than those recommended by SHARP.

Contact and consult with a SHARP representative if there are any questions about the contents of this publication.

### 1. Application

This specification applies to color TFT-LCD module, LQ057Q3DC12.

### 2. Summary and Features

This module is a color active matrix LCD module incorporating amorphous silicon TFT (Thin Film Transistor). It is composed of a color TFT-LCD panel, driver ICs, control circuit (PWB), FPC, front and back polarizer, sealed case, backlight unit. Graphics and texts can be displayed on a  $320 \times \text{RGB} \times 240$  dots panel with 262,144 colors by suitable control supplying from the outside.

It isn't composed DC/AC inverter for a backlight drive.

- The input of QVGA and VGA signal is possible.
- Wide Viewing Angle technology is adopted. (The most suitable viewing angle is in the 12 o'clock direction.)
- By adopting an active matrix drive, a picture with high contrast is realized.
- Reflection due to external light is minimized through the use of a low reflection black matrix.
- A thin, light and compact module is accomplished through the use of COG mounting technology.
- Through the use of high color purity color filter and TN-normally white mode excelled in color reproducibility, an image with highly natural color reproduction is realized.
- High viewing angle and high brightness (500cd/m<sup>2</sup>).
- An inverted video display in the vertical / horizontal directions is possible.
- This module is adapted to RoHS compliance.

### 3. Mechanical specifications

table 3-1

Parameter	Specifications	Units
Screen size	14.4 (5.7 inch) diagonal	cm
Active area	115.2 (H) × 86.4 (V)	mm
Display format	320(H) × 240(V)	pixels
	(1 pixel = R + G + B dots)	
Dot pitch	0.360 (H) × 0.360 (V)	mm
Pixel configuration	R,G,B Stripe configuration	
Display mode	Normally white	
Outline dimension 【Note1-1】	144.0 (W) × 104.6 (H) × 13.0(D)	mm
Mass	220 ± 20	g
Surface treatment (Surface hardness)	Hard coat (3H)	

【Note 1-1】

A connector of backlight is excepted.

A figure of outline dimension is shown in Fig. 1.

## 4. Input terminal

## 4-1. TFT-LCD panel driving part

CN1 Used connector: FH12-33S-0.5SH(55) (HIROSE ELECTRIC CO., LTD.)

Table 4-1 Functional table of CN1 terminals

Pin No.	Symbol	Description	Polarity
1	GND	ground	
2	CK	Clock signal for sampling each data signal	
3	Hsync	Horizontal synchronous signal	Negative
4	Vsync	Vertical synchronous signal	Negative
5	GND	ground	
6	R0	RED data signal(LSB)	
7	R1	RED data signal	
8	R2	RED data signal	
9	R3	RED data signal	
10	R4	RED data signal	
11	R5	RED data signal(MSB)	
12	GND	ground	
13	G0	GREEN data signal(LSB)	
14	G1	GREEN data signal	
15	G2	GREEN data signal	
16	G3	GREEN data signal	
17	G4	GREEN data signal	
18	G5	GREEN data signal(MSB)	
19	GND	ground	
20	B0	BLUE data signal(LSB)	
21	B1	BLUE data signal	
22	B2	BLUE data signal	
23	B3	BLUE data signal	
24	B4	BLUE data signal	
25	B5	BLUE data signal(MSB)	
26	GND	ground	
27	ENAB	Signal to settle the horizontal display position 【Note4-1】	Positive
28	Vcc	+3.3V power supply	
29	Vcc	+3.3V power supply	
30	R/L	Selection signal for horizontal scanning direction 【Note4-2】 ("L" : Normally, "H" : Right-and-Left reversal)	
31	U/D	Selection signal for vertical scanning direction 【Note4-2】 ("H" : Normally, "L" : Up-and-Down reversal)	
32	V/Q	Selection signal for VGA or QVGA ("H" : VGA, "L" : QVGA)	
33	GND	ground	

【Note 4-1】 The horizontal display start timing is settled in accordance with a rising timing of ENAB signal. In case ENAB is fixed "Low", the horizontal start timing is determined as described in Fig7. Don't keep ENAB "High" during operation.

【Note 4-2】

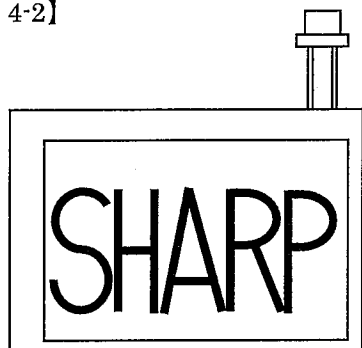

R/L = L, U/D = H

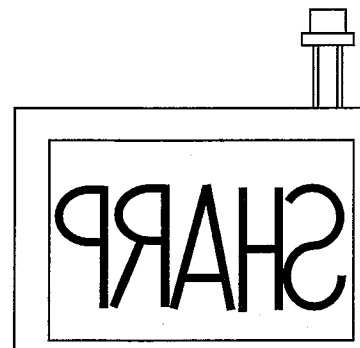

R/L = H, U/D = H

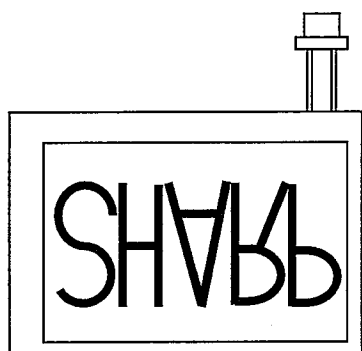

R/L = L, U/D = L

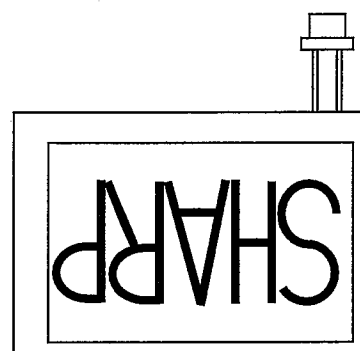

R/L = H, U/D = L

#### 4-2. Backlight fluorescent tube driving part

CN2 Used connector : BHR-03VS-1 (JST Co., Ltd.)

Suitable connector : SM02(8.0)B-BHS-1N-TB (JST Co., Ltd.)

Table 4-2 Functional table of CN2 terminals

Terminal No.	symbol	function	Color of FL cable
1	V <sub>LOW</sub>	input terminal (Low Voltage Side)	White
2	NC	Non connection	--
3	V <sub>HIGH</sub>	input terminal (High Voltage Side)	Red

#### 5. Absolute maximum ratings

Table 5-1

Parameter	Symbol	Condition	Ratings	Unit	Note
Input voltage	V <sub>I</sub>	T <sub>a</sub> =25°C	-0.3 ~ +6.0V	V	【Note 5-1】
+3.3V power supply voltage	V <sub>CC</sub>	T <sub>a</sub> =25°C	0 ~ +4.0	V	
Storage temperature	T <sub>stg</sub>	--	-30 ~ +80	°C	【Note 5-2,3】
Operating temperature (Panel surface temperature)	T <sub>opr1</sub>	--	-10 ~ +70	°C	【Note5-2,3,4】
Operating temperature (Ambient temperature)	T <sub>opr2</sub>	--	-10 ~ +70	°C	【Note 5-5】

【Note 5-1】 CK, R0~R5, G0~G5, B0~B5, Hsync, Vsync, ENAB, R/L, U/D, V/Q

【Note 5-2】 This rating applies to all parts of the module and should not be exceeded.

【Note 5-3】 Maximum wet-bulb temperature is less than 39°C. Condensation of dew must be avoided as electrical current leaks will occur, causing a degradation of performance specifications.

【Note 5-4】 The operating temperature only guarantees operation of the circuit. For contrast, speed response, and other factors related to display quality, judgment is done using the ambient temperature T<sub>a</sub> = +25°C.

【Note 5-5】 Ambient temperature when the backlight is lit (reference value).

6. Electrical characteristics

6-1. TFT-LCD panel driving section

Table 6-1.

Ta=25°C

Parameter		Symbol	MIN	TYP	MAX	Unit	Remarks
+3.3V power supply	Supply voltage	V <sub>cc</sub>	+3.0	+3.3	+3.6	V	【Note 6-1】
	Current dissipation	I <sub>cc</sub>	—	130	160	mA	【Note 6-2】
Permissible input ripple		V <sub>RF</sub>	—	—	100	MV <sub>pp</sub>	V <sub>cc</sub> =+3.3V
Input Low voltage		V <sub>IL</sub>	0	—	0.3V <sub>cc</sub>	V	【Note 6-3】
Input High voltage		V <sub>IH</sub>	0.7V <sub>cc</sub>	—	+5.5	V	
Input leak current (Low)		I <sub>OL</sub>	—	—	10	μA	V <sub>I</sub> =0V 【Note 6-3】
Input leak current (High)		I <sub>OH1</sub>	—	—	10	μA	V <sub>I</sub> =3.3~5.0V 【Note 6-4】
		I <sub>OH2</sub>	—	—	100	μA	V <sub>I</sub> =3.3~5.0V 【Note 6-5】

【Note 6-1】

V<sub>cc</sub> turn-on/off conditions.

- t1 ≤ 20ms
- 0 < t2 ≤ 50ms
- 0 < t3 ≤ 1s
- 1s < t4

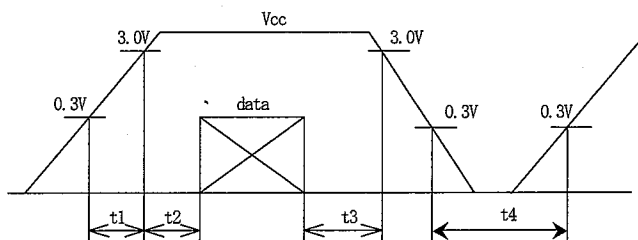

V<sub>cc</sub>-dip conditions

- 1) 2.4V < V<sub>cc</sub> < 3.0V

t<sub>d</sub> ≤ 20msec

- 2) At V<sub>cc</sub> < 2.4V

V<sub>cc</sub>-dip conditions should also follow the V<sub>cc</sub> turn-on/off conditions.

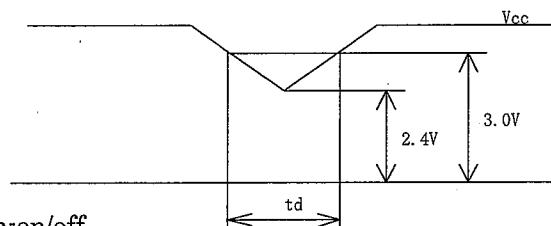

【Note 6-2】 V<sub>cc</sub> = 3.3V, V/Q = "H"

Typical current situation: Timing; Typical, 64-gray-bar pattern.

Max current situation: Timing; Typical, Vertical stripe pattern alternating

0 gray scale (GS0) with 42 gray scale (GS42) every 1 dot.

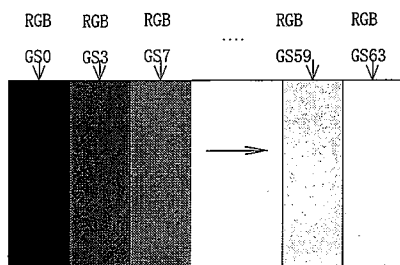

Typical current situation

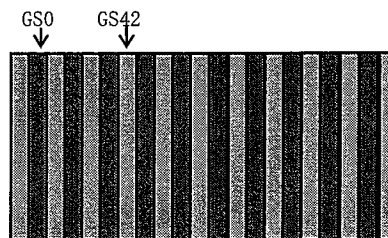

Max current situation

【Note 6-3】 CK,R0~R5,G0~G5,B0~B5,Hsync,Vsync,ENAB,R/L,U/D,V/Q

【Note 6-4】 CK,R0~R5,G0~G5,B0~B5,Hsync,Vsync,R/L,U/D

【Note 6-5】 ENAB, V/Q

## 6-2. Backlight driving section

The backlight system is an edge-lighting type with single CCFT (Cold Cathode Fluorescent Tube). The characteristics of Lamp are shown in the following table.

Table 6-2

Parameter	Symbol	MIN	TYP	MAX	Unit	Remarks	
lamp voltage	V L	620	690	760	Vrms	I L = 5 mArms	
lamp current	I L	4.5	5.0	5.5	mArms	ordinary state	
lamp power	WL	—	3.5	—	W	ratings	
lamp frequency	f L	30	—	60	kHz		
kick-off voltage	Ta=+25°C	V S	—	—	1350	Vrms	A shield is connected to GND.
	Ta=-10°C		—	—	1470		

( Inverter : HIU-288 [ Output condenser : 22pF ] TOSHIBA HARISON LIGHTING co. Ltd.)

## 【Caution】

Use the inverter providing symmetrical sine-wave in positive/negative polarity with no spike. A shield(module's metal shield) should be connected to GND of inverter circuit.

## 7. Timing Characteristics of input signals

Timing diagrams of input signal are shown in Fig.7

### 7-1. Timing characteristics

Table 7-1

Parameter	Symbol	MIN	TYP	MAX	Unit	Remarks
Clock frequency	1/Tc	—	25.18	28.33	MHz	V/Q = H
		—	6.3	7.0		V/Q = L
Duty ratio	TH/T	40	50	60	%	
Data Setup time	Tds	5	—	—	ns	
		10	—	—		
Horizontal sync. signal Cycle	TH	30.0	31.8	—	μs	V/Q = H
		770	800	900	clock	
	TH	50.0	63.6	—	μs	V/Q = L
		360	400	450	clock	
Pulse width	THp	2	96	200	clock	
Vertical sync. signal Cycle	TV	515	525	560	line	V/Q = H
		251	262	280		V/Q = L
	Pulse width	TVp	2	—	34	line
Horizontal display period	THd	320	320	320	clock	
Hsync-Clock phase difference	THc	10	—	Tc-10	ns	
Hsync-Vsync phase difference	TVh	0	—	TH-THp	μs	
Vertical display start position	TVs	34	34	34	line	V/Q = H
		7	7	7		V/Q = L

Note) In case of lower frequency, the deterioration of display quality, flicker etc., may be occurred.

### 7-2. Horizontal display position

The horizontal display position is determined by the rising edge of ENAB signal.

Table 7-2

Parameter	symbol	Min.	Typ.	Max.	Unit	Remark
Enable signal Setup time	Tes	5	—	Tc-10	ns	
	Tep	2	320	TH-10		clock
Hsync-Enable signal phase difference	The	44	—	TH-664	clock	V/Q = H
		2	—	TH-340		V/Q = L

Note) When ENAB is fixed "Low", the display starts from the following data as shown in Fig.7.

V/Q = "H" C104 (clock) V/Q = "L" C52 (clock)



7-3. Vertical display position

The Vertical display start position (TVs) is fixed 34 line (V/Q = H) and 7 line (V/Q = L).  
 ENAB signal has no relation to the vertical display position.

7-4. Input Data Signals and Display Position on the screen

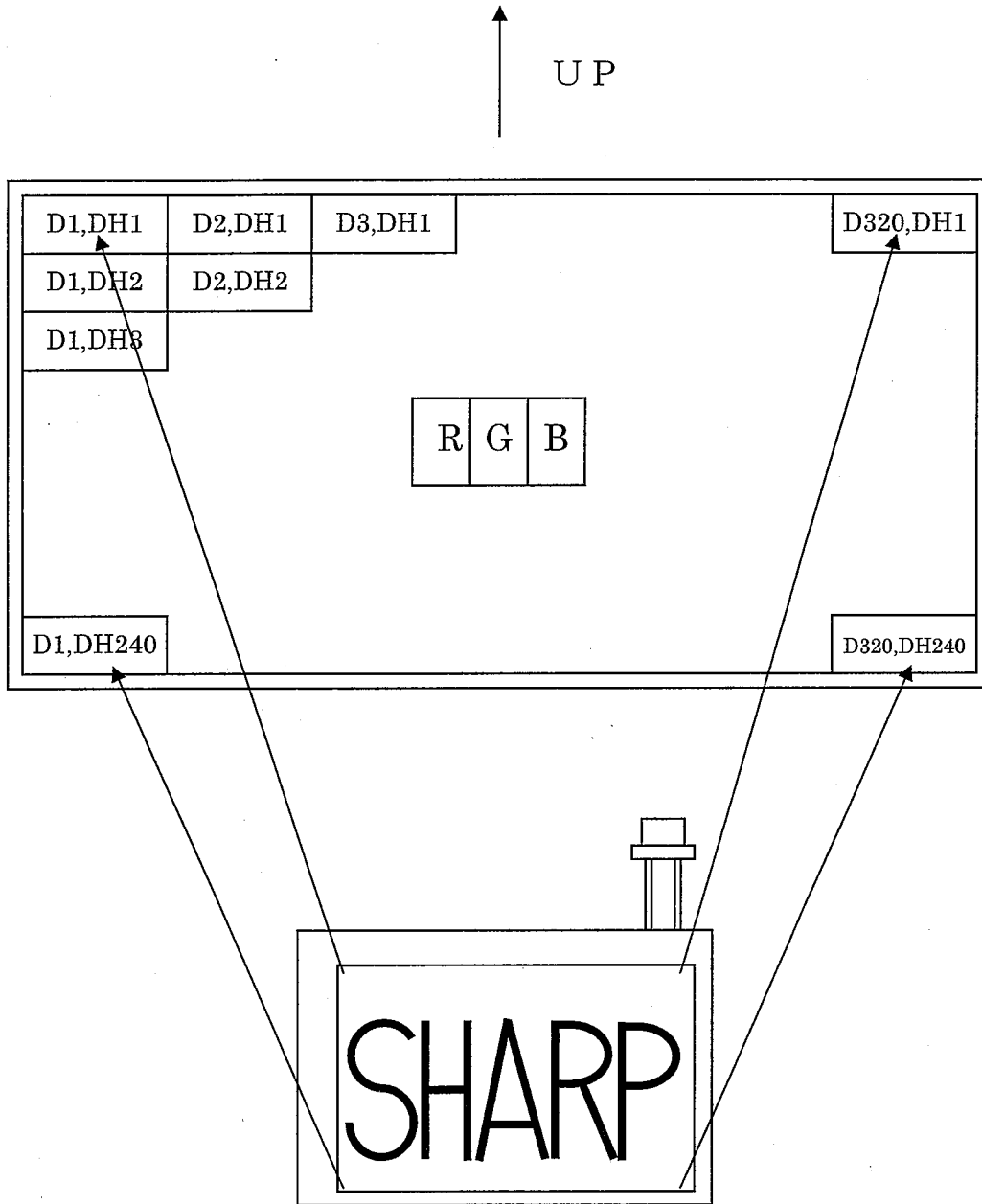

Display position of input data (H,V)

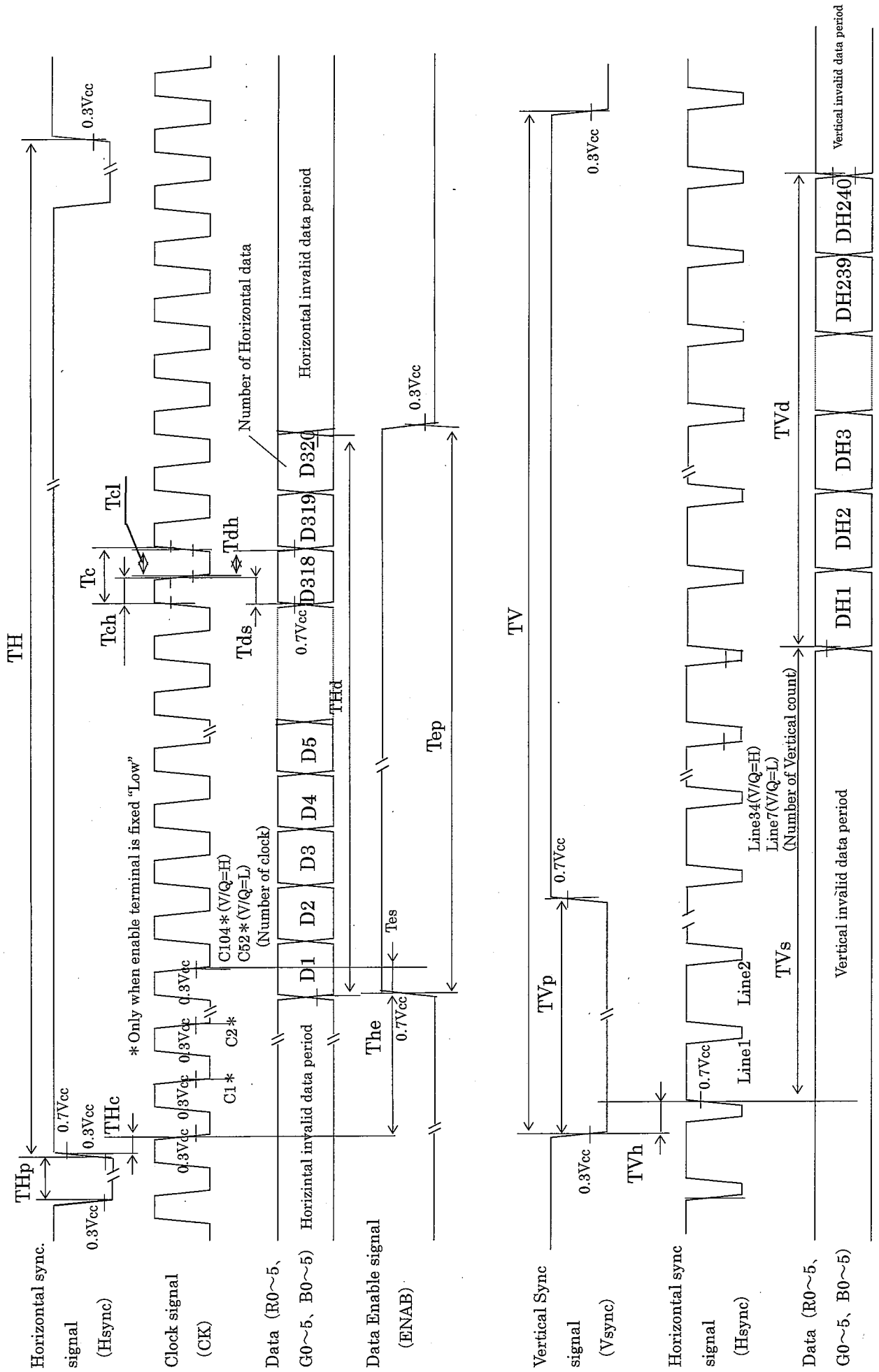

Fig 7. Input signal waveforms

(8) Input Signals, Basic Display Color and Gray Scale of Each Color

Colors & Gray scale	Data signal																			
	Gray Scale	R0	R1	R2	R3	R4	R5	G0	G1	G2	G3	G4	G5	B0	B1	B2	B3	B4	B5	
Basic color	Black	—	0	0	0	0	0	0	0	0	0	0	0	0	0	0	0	0	0	0
	Blue	—	0	0	0	0	0	0	0	0	0	0	0	0	1	1	1	1	1	1
	Green	—	0	0	0	0	0	0	1	1	1	1	1	1	0	0	0	0	0	0
	Cyan	—	0	0	0	0	0	0	1	1	1	1	1	1	1	1	1	1	1	1
	Red	—	1	1	1	1	1	1	0	0	0	0	0	0	0	0	0	0	0	0
	Magenta	—	1	1	1	1	1	1	0	0	0	0	0	0	1	1	1	1	1	1
	Yellow	—	1	1	1	1	1	1	1	1	1	1	1	1	0	0	0	0	0	0
	White	—	1	1	1	1	1	1	1	1	1	1	1	1	1	1	1	1	1	1
Gray Scale of red	Black	GS0	0	0	0	0	0	0	0	0	0	0	0	0	0	0	0	0	0	0
	↑	GS1	1	0	0	0	0	0	0	0	0	0	0	0	0	0	0	0	0	0
	Darker	GS2	0	1	0	0	0	0	0	0	0	0	0	0	0	0	0	0	0	0
	↑	↓			↓					↓					↓					
	↓	↓			↓					↓					↓					
	Brighter	GS61	1	0	1	1	1	1	0	0	0	0	0	0	0	0	0	0	0	0
	↓	GS62	0	1	1	1	1	1	0	0	0	0	0	0	0	0	0	0	0	0
	Red	GS63	1	1	1	1	1	1	0	0	0	0	0	0	0	0	0	0	0	0
Gray Scale of green	Black	GS0	0	0	0	0	0	0	0	0	0	0	0	0	0	0	0	0	0	0
	↑	GS1	0	0	0	0	0	0	1	0	0	0	0	0	0	0	0	0	0	0
	Darker	GS2	0	0	0	0	0	0	0	1	0	0	0	0	0	0	0	0	0	0
	↑	↓			↓					↓					↓					
	↓	↓			↓					↓					↓					
	Brighter	GS61	0	0	0	0	0	0	1	0	1	1	1	1	0	0	0	0	0	0
	↓	GS62	0	0	0	0	0	0	0	1	1	1	1	1	0	0	0	0	0	0
	Green	GS63	0	0	0	0	0	0	1	1	1	1	1	1	0	0	0	0	0	0
Gray Scale of bleu	Black	GS0	0	0	0	0	0	0	0	0	0	0	0	0	0	0	0	0	0	0
	↑	GS1	0	0	0	0	0	0	0	0	0	0	0	0	1	0	0	0	0	0
	Darker	GS2	0	0	0	0	0	0	0	0	0	0	0	0	0	1	0	0	0	0
	↑	↓			↓					↓					↓					
	↓	↓			↓					↓					↓					
	Brighter	GS61	0	0	0	0	0	0	0	0	0	0	0	0	1	0	1	1	1	1
	↓	GS62	0	0	0	0	0	0	0	0	0	0	0	0	0	1	1	1	1	1
	Bleu	GS63	0	0	0	0	0	0	0	0	0	0	0	0	1	1	1	1	1	1

0 :Low level voltage    1 :High level voltage

Each basic color can be displayed in 64 gray scales from 6 bit data signals. According to the combination of total 18 bit data signals, the 262,144-color display can be achieved on the screen.

## 9. Optical characteristics

Table 9-1

Ta=25°C, VCC = +3.3V

Parameter	Symbol	Condition	Min	Typ	Max	Unit	Remarks	
Viewing angle range	$\theta_{21}, \theta_{22}$	CR $\geq$ 5	60	65	—	° (degree)	【Note 9-1】	
	$\theta_{11}$		60	65	—	° (degree)		
	$\theta_{12}$		35	40	—	° (degree)		
Contrast ratio	CRmax	Optimal viewing angle	250	350	—		【Note 9-2】	
Response time	Rise	$\tau_r$	—	8	20	ms	【Note 9-3】	
	Fall							$\tau_d$
White chromaticity	x	IL=5mArms	0.263	0.313	0.363		【Note 9-4】	
	y		0.279	0.329	0.379			
Luminance	Y		350	500	—	cd/m <sup>2</sup>		
lamp life time	+25°C	-	continuation	40,000	50,000	—	hour	【Note 9-5】

Lamp test in the module is made with the following inverter:

HIU-288 [ Output condenser : 22pF ] TOSHIBA HARISON LIGHTING co. Ltd.

※ The optical specifications are measured 30 minute after turing lamp on and in a dark room or equivalent condition, according to the method shown in Fig.9-1 below.

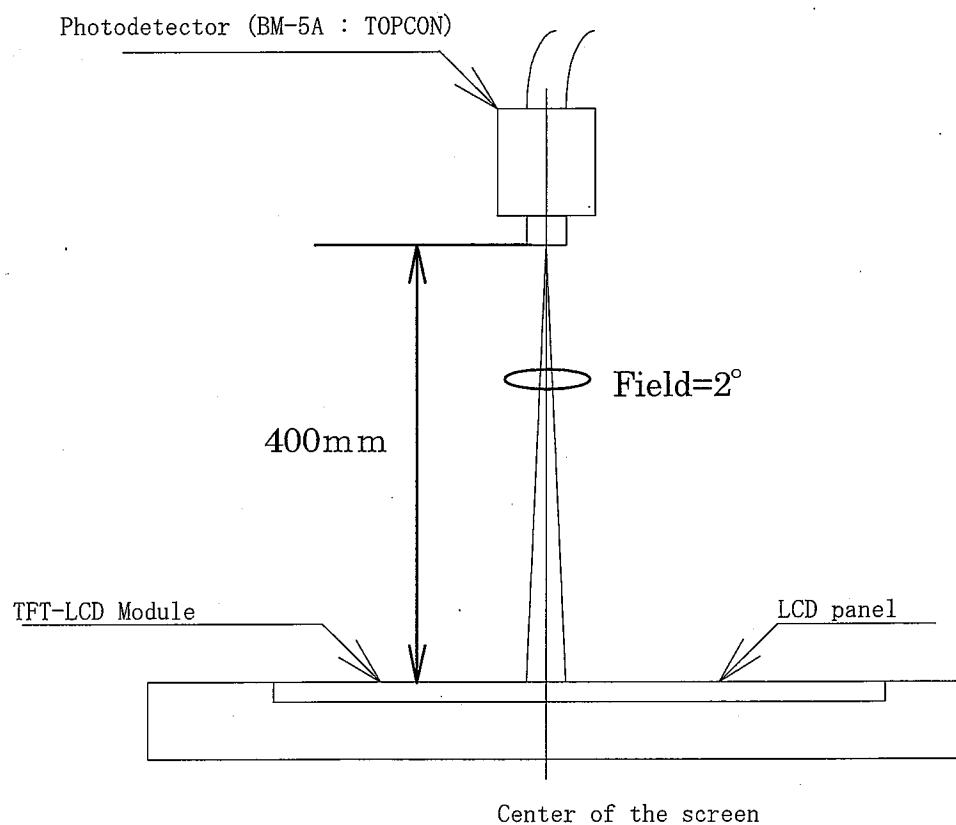
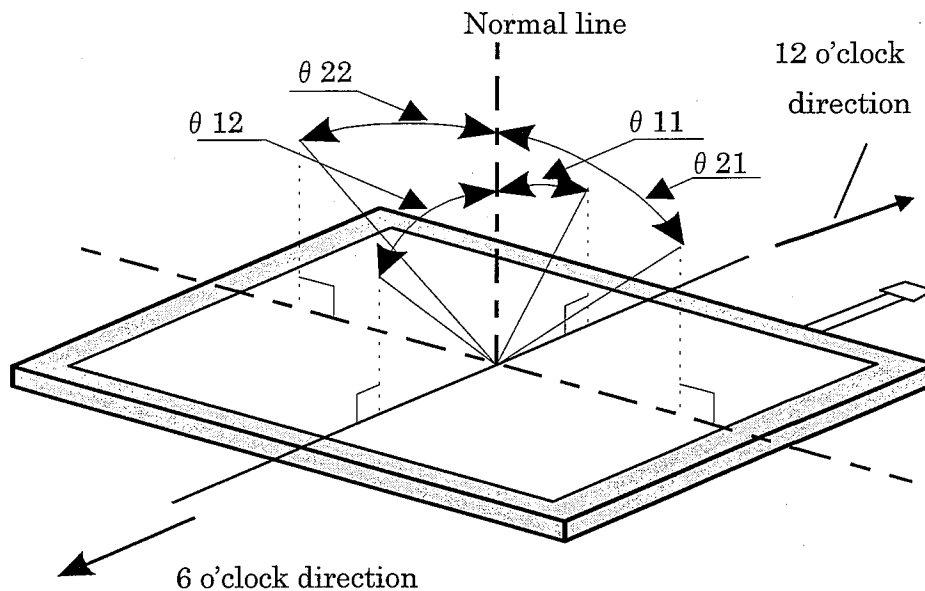

Fig.9-1 Optical characteristics measurement method

【Note 9-1】 Viewing angle range is defined as follows.



The best viewing angle of this module is slightly leaned to 12 o'clock from normal line.  
 Where  $\theta_{11} > \theta_{max}$ , gray scale is reversed partially.  
 Where  $\theta_{11} < \theta_{max}$ , or in  $\theta_{12}$  direction, gray scale isn't reversed.

【Note 9-2】 Contrast ratio is defined as follows:

$$\text{Contrast ratio(CR)} = \frac{\text{Luminance (brightness) with all pixels white}}{\text{Luminance (brightness) with all pixels black}}$$

※ Measurement point : Center of the active area

【Note 9-3】 Response time is obtained by measuring the transition time of photo detector output, when input signals are applied so as to make the area "black" to and from "white".

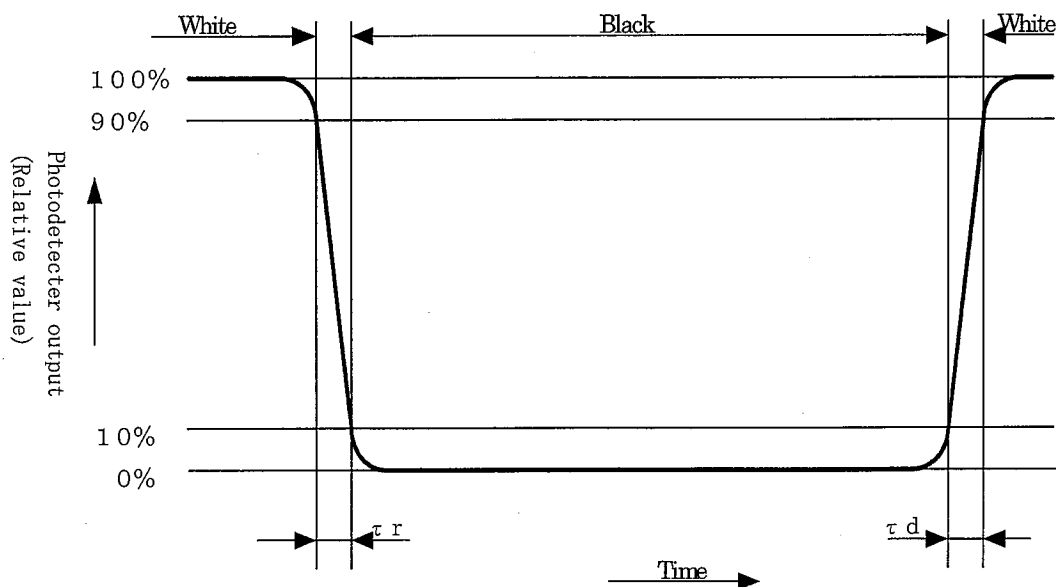

【Note 9-4】 This parameter should be measured at the center of the screen and 30 minutes after turn-on.  
 Inverter frequency: 49kHz  
 The characteristics are measured when the driver circuit is not powered.

【Note 9-5】 The data for lamp is for your reference, because lamp is consumable component.  
 a) Lamp life time is defined by either 1 or 2 below.  
 (Continuous turning on at  $T_a=25^\circ\text{C}$ ,  $I_L=5\text{mA rms}$ )

- ① When a brightness of lamp surface become 50% of the initial value under the standard condition.
  - ② When a kick-off voltage in  $T_a = -10^\circ\text{C}$  exceeded maximum value(1470 Vrms) at the output of inverter circuitry.
- b) In case of operating under lower temp. environment, the lamp exhaustion is accelerated and the brightness becomes lower.  
(Continuous operating for around 1 month under lower temp. condition may reduce the brightness to half of the original brightness.)

## 10. Handling instructions

### 10-1. Mounting of modules

- ① The TFT-LCD module is designed to be mounted on equipment using the mounting tabs in the four corners of the module at the rear side. On mounting the module, as the nominal diameter 3.0mm tapping screw (fastening torque is 0.25 through 0.30 N·m) is recommended, be sure to fix the module on the same plane, taking care not to wrap or twist the module. The depth of tapping screw embedded into LCD module must be less than 5mm.

The pressing module, (ex. touching switch etc.) causes disordered image. So taking care for pressure not to conduct directly to LCD module.

- ② Please power off the module before you connect or disconnect input connector.
- ③ Connect the metallic shielding cases of the module and the ground pattern of the inverter circuit firmly. If that connection is not perfect, there may be a possibility that the following problems happen.
  - a) The noise from the backlight unit will increase.
  - b) The output from inverter circuit will be unstable.
  - c) In some cases, a part of module will heat up.

### 10-2. Precautions in mounting

- ① Polarizer which is made of soft material and susceptible to flaw must be handled carefully.
- ② Method of removing dust from polarizer.
  - Blow off dust with N2 blower for which static electricity preventive measure has been taken.
  - Since the polarizer is easily damaged, wiping should be avoided. If the panel has stain or finger grease, we recommend to use adhesive tape to softly remove them from the panel. Inevitable, wipe off by cleaning cloth for a lens with carefully, breathing on it.
- ③ When metal part of the TFT-LCD module (shielding lid and rear case) is soiled, wipe it with soft dry cloth. For stubborn dirties, wipe the part, breathing on it.
- ④ Wipe off water drop or finger grease immediately. Long contact with water may cause discoloration or spots.
- ⑤ TFT-LCD module uses glass which breaks or cracks easily if dropped or bumped on hard surface. handle with care.
- ⑥ Since CMOS LSIs are incorporated in this module, take care of electrostatic and earth human body while handling.

### 10-3. Caution of product design

The notes and cautions below should be followed when product is designed with this module.

- ① The LCD module should be protected against water salt-water by the waterproof cover.
- ② Take enough shielding countermeasure not to interfere to peripheral electric device.

### 10-4. Others

- ① Do not expose the module to direct sunlight or intensive ultraviolet rays for many hours; liquid crystal is deteriorated by ultraviolet rays.
- ② If stored at the temperature lower than rated temperature, the liquid crystal may freeze and it may cause LCD panel damage. If storage temperature exceeds the specified rating, the molecular orientation of the liquid crystal may change to that of a liquid, and they may not revert to their original state. Store the module in normal room temperature.
- ③ The voltage of beginning electric discharge may over the normal voltage because of leakage current from approach conductor by to draw lump lead line around.
- ④ If LCD panel breaks, there may be a possibility that the liquid crystal escapes from the panel. If the liquid crystal drip into the eyes or mouth washes it out immediately.
- ⑤ The caution to other ordinal electronic component should be followed also.

## 11. Shipping requirements

- a) Number of layers of cartons in pile : 12 layers max.
- b) Maximum number of product contained: 20 units per 1 carton.
- c) Carton size : 442mm(W) × 390mm(H) × 170mm(D)
- d) Total mass ( for 20 units ) : Approximately 5.5 k g
- e) Carton stock environment :
  - ① Temperature 0°C to 40°C
  - ② Humidity 60%RH or less
  - ③ Atmosphere Harmful gases such as acid and alkali which corrode electric components and wires must not be detected.
  - ④ Storage period Approximately 3 months
  - ⑤ Opening of package To prevent TFT-LCD module from being damaged by electrostatic, adjust the humidity to 50%RH or higher and provide an appropriate measure for electrostatic earthing before opening the package.

## 12. Others

- a) Adjusting volumes have been set optimally before shipment. Therefore, do not change any adjusted values. If adjusted values are changed, the specifications described here may not be satisfied.
- b) Disassembled the module, it may cause malfunction.
- c) Be careful since image retention may occur when a fixed pattern is displayed for a long time.
- d) Input/Output connector for TFT-LCD panel driving part  
Used connector : FH12-33S-0.5SH(55) (HIROSE ELECTRIC CO., LTD.)
  - 1) Fit FPC : Refer to the following figure
  - 2) Keeping power of terminal : 0.9N/pin or more  
[ Every terminal is pulled out  $25 \pm 3$ mm/minute ]
  - 3) Endurance of insert/pull out : Less than double of the initial resistance value  
[ The electrical resistance value of the contact changed by the repeated insertion/pulling out by 20 times to and from the matching FPC ]

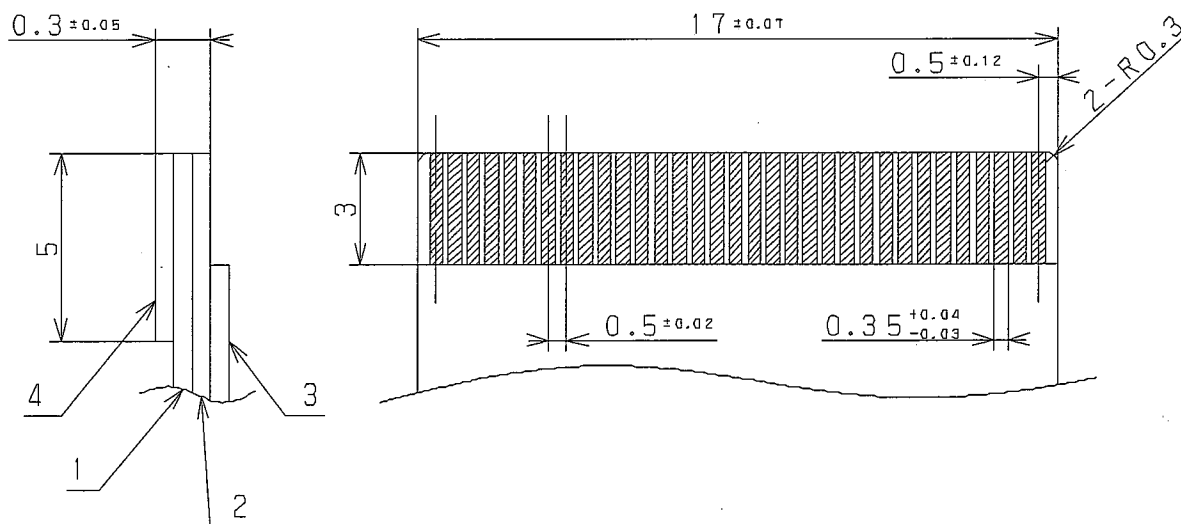

No.	Parameter	Material
1	Base material	Polyimide or the equivalent [ 25um thickness ]
2	Copper leaf	Copper leaf [ 35um thickness ] gold leaf [ 2um or more thickness ]
3	Coverlay	Polyimide or the equivalent
4	Reinforced sheet	Polyester, polyimide or the equivalent [ 188um thickness ]

Fit FPC for Input/Output connector : 0.5mm pitch



## 13. Reliability Test Conditions for TFT-LCD Module

Table 13-1

No.	Test items	Test conditions
1	High temperature storage test	Leaves the module at $T_a = +80^\circ\text{C}$ for 240h <span style="float: right;">【Note 1】</span>
2	Low temperature storage test	Leaves the module at $T_a = -30^\circ\text{C}$ for 240h <span style="float: right;">【Note 1】</span>
3	High temperature and high humidity operating test	Operates the module at $T_p = +40^\circ\text{C}$ , 95%RH for 240h (No condensation) <span style="float: right;">【Note 1】</span>
4	High temperature operating test	Operates the module at $T_p = +70^\circ\text{C}$ for 240h <span style="float: right;">【Note 1】</span>
5	Low temperature operating test	Operates the module at $T_a = -10^\circ\text{C}$ for 240h <span style="float: right;">【Note 1】</span> (The lifetime of a CCFT is not included)
6	Strength against ESD	$\pm 200\text{V} \cdot 200\text{pF}(0\Omega)$ 1 time for each terminals
7	Shock test (non-operating)	$490\text{m/s}^2 \cdot 6\text{ms}$ , $\pm X$ ; $\pm Y$ ; $\pm Z$ 3 times for each direction (JIS C0041, A-7 Condition C)
8	Vibration test (non-operating)	Frequency : $5 \sim 57\text{Hz}$ , Stroke : $0.15\text{mm}$ Frequency : $58 \sim 500\text{Hz}$ , Acceleration : $9.8\text{m/s}^2$ Sweep cycle : 11 minutes X,Y,Z 1 hours for each directions (total 3 hours) <span style="float: right;">【Note 2】</span> (JIS D1601)
9	Thermal shock test	$T_a = -30^\circ\text{C} \sim +80^\circ\text{C}$ , 200 cycles (0.5h) (0.5h)

## 【Result evaluation criteria】

Under the display quality test conditions with normal operation state, these shall be no change which may affect practical display function.

【Note 1】  $T_a$ = Ambient temperature,  $T_p$ = Panel surface temperature

【Note 2】 X,Y,Z directions are shown as follows:

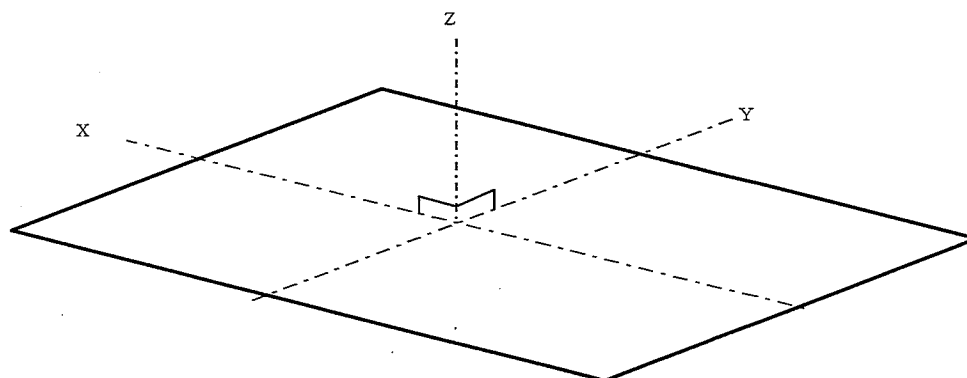

SHARP

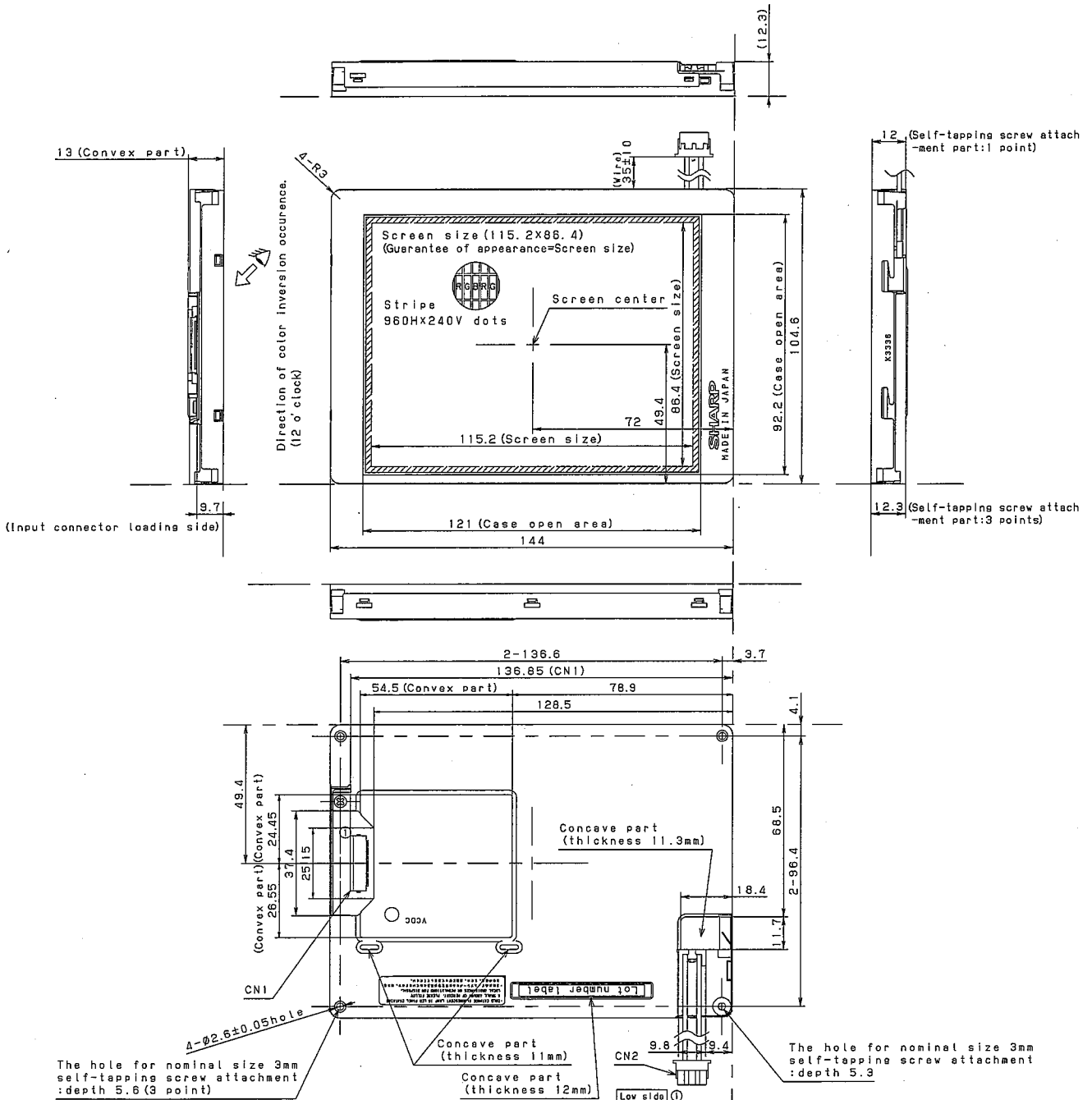

① Input terminal arrangement

GND	CK	Hsync	Vsync	GND	R0	R1	R2	R3	R4	R5	GND	G0	G1	G2	G3	G4	G5	GND	B0	B1	B2	B3	B4	B5	GND	ENAB	Vcc	R/L	U/D	V/Q	GND
-----	----	-------	-------	-----	----	----	----	----	----	----	-----	----	----	----	----	----	----	-----	----	----	----	----	----	----	-----	------	-----	-----	-----	-----	-----

- 1) Take care in set design to hide the scratches and bubbles appeared on the polarizer or other flame area which is located outside of active area.
- 2) CN1: I/O connector is FH12-33S-0.5SH (55) (HIROAE electric)  
CN2: CCFT connector is BHR-03VS-1 (JST)
- 3) The whole curvature is not included thickness direction.
- 4) Recommendation screw is nominal size 3mm tapping, amount of invasion: 5mm.

unit:mm  
General tolerance is ±0.5

Please do not copy this material and do not disclose this to third party.

DATE	05.05.25	SCALE	1/1		
MODEL	LIQ0157IQ3D112111				
DRAWING NO	LCM1-015012151	size	A2	No.	DATE
SHARP CO. LTD			REVISION		
MOBILE LCD DESIGN CENTER I			ENGINEERING DEPT. I		

Fig. 1 DIMENSIONS OF THE MODULE

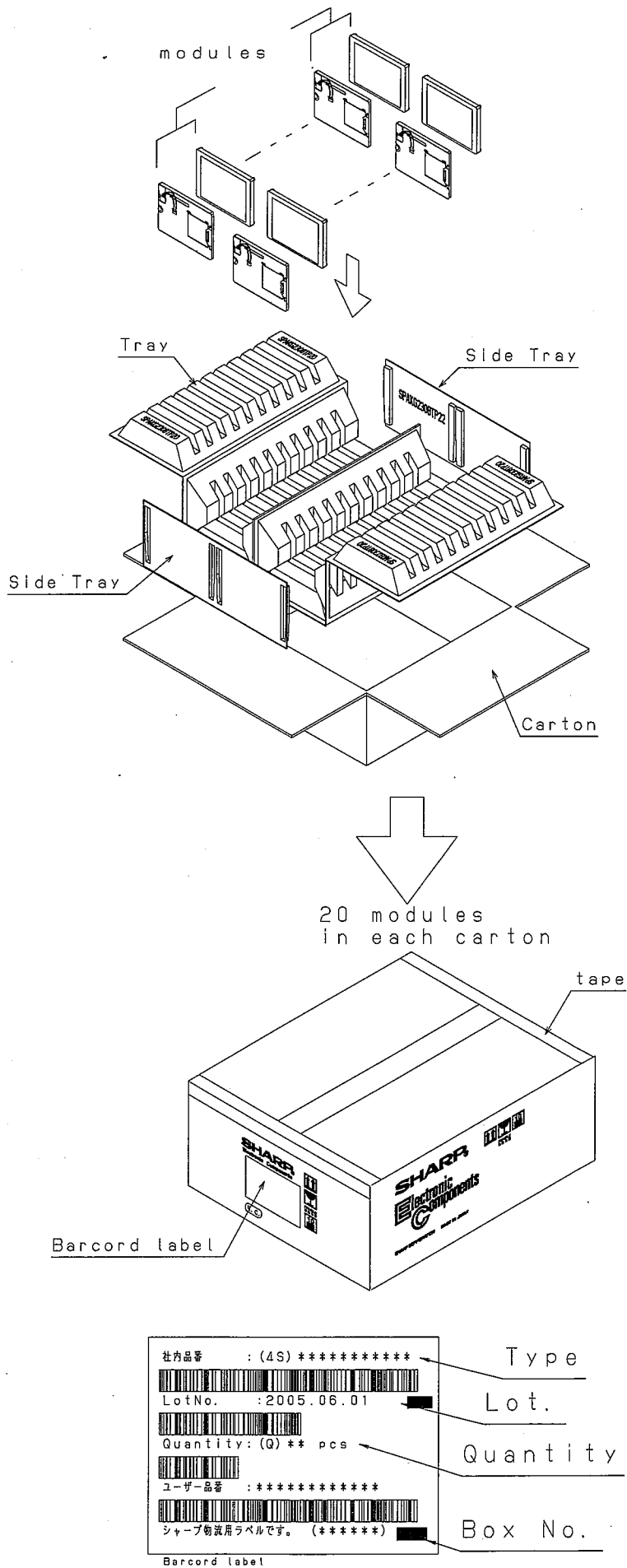

Fig.2-PACKING FORM