

# MAXIM

## CMOS Micropower Inverting Switching Regulator

MAX634/MAX4391

### General Description

Maxim's MAX634 and MAX4391 CMOS DC-DC regulators are designed for simple, efficient, inverting DC-DC converter circuits. The MAX634 and MAX4391 switching regulators provide all control and power handling functions in a compact 8 pin package: a 1.25V bandgap reference, an oscillator, a comparator for output voltage regulation, and a 525mA P-channel output MOSFET. A second comparator is also provided for convenient low battery detection.

The operating current is typically 100 $\mu$ A and is nearly independent of output switch current and duty cycle, thus ensuring high efficiency even in low power battery operated systems. Operating in the inverting configuration, the MAX634 and MAX4391 can convert a positive input voltage in the range of +3V to 16.5V to any negative output voltage up to -20V.

These devices are pin compatible enhancements of the Raytheon bipolar circuit, RC4391. Improvements include significantly higher efficiency, extended low voltage operation and improved output voltage accuracy (MAX634).

Maxim manufactures a broad line of DC-DC converters, including the MAX635, MAX636, and MAX637; which reduce the external component count in fixed -5V, -12V, and -15V output DC-DC converter circuits. See Table 2 on the last page of this data sheet for a summary of other Maxim DC-DC converters.

### Applications

- High Efficiency Battery Powered DC-DC Converters
- Board Level, Local Power Supply Generation
- Regulated Negative Output Power Supplies
- +5V to  $\pm$ 12V or  $\pm$ 15V Power Conversion
- Regulated Voltage Inverters

### Pin Configuration

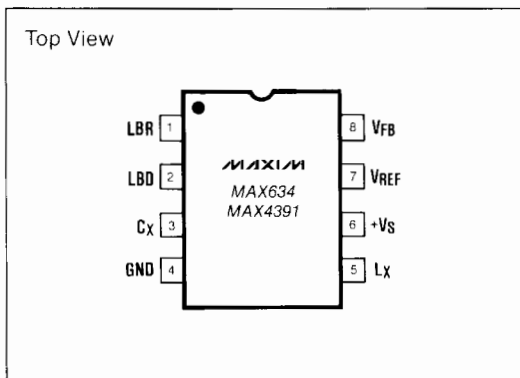

### Features

- ◆ Converts Positive Voltage to Negative Voltage
- ◆ Low Operating Current—100 $\mu$ A
- ◆ Compact 8 Pin MiniDIP and SO Packages
- ◆ High Efficiency—85% Typical
- ◆ Low Battery Detector
- ◆ 4% Output Voltage Accuracy (MAX634)
- ◆ +3V to +16.5V Input Voltage Range
- ◆ Adjustable Output Voltage
  - Up to -20V with Simple Coil
  - Virtually Unlimited Voltage with Transformer

### Ordering Information

PART	TEMP. RANGE	PACKAGE
MAX634C/D	0°C to +70°C	Dice
MAX634CPA	0°C to +70°C	8 Lead Plastic DIP
MAX634CSA	0°C to +70°C	8 Lead Small Outline
MAX634EPA	-40°C to +85°C	8 Lead Plastic DIP
MAX634ESA	-40°C to +85°C	8 Lead Small Outline
MAX634EJA	-40°C to +85°C	8 Lead CERDIP
MAX634MJA	-55°C to +125°C	8 Lead CERDIP
MAX4391C/D	0°C to +70°C	Dice
MAX4391CPA	0°C to +70°C	8 Lead Plastic DIP
MAX4391CSA	0°C to +70°C	8 Lead Small Outline
MAX4391EPA	-40°C to +85°C	8 Lead Plastic DIP
MAX4391ESA	-40°C to +85°C	8 Lead Small Outline
MAX4391EJA	-40°C to +85°C	8 Lead CERDIP
MAX4391MJA	-55°C to +125°C	8 Lead CERDIP

### Typical Operating Circuit

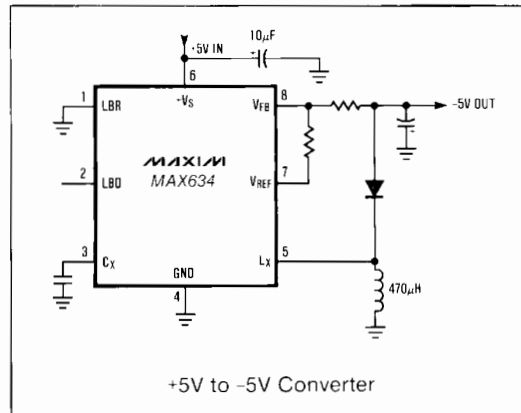

## CMOS Micropower Inverting Switching Regulator

### ABSOLUTE MAXIMUM RATINGS

Supply Voltage (Note 1)	+18V
Storage Temperature Range	-65°C to +160°C
Lead Temperature (Soldering, 10 seconds)	+300°C
Operating Temperature Range	
MAX634C, MAX4391C	0°C to -70°C
MAX634E, MAX4391E	-40°C to +85°C
MAX634M, MAX4391M	-55°C to +125°C

Power Dissipation	
Plastic DIP (derate 8.33mW/°C above +50°C)	625mW
Small Outline (derate 6mW/°C above +50°C)	450mW
CERDIP (derate 8mW/°C above +50°C)	800mW
Input Voltage, Pins 1, 3, 8 (Note 2)	-0.3V to $+V_S + 0.3V$
$I_X$ Output Current	525mA Peak
LBD Output Current	50mA

Stresses above those listed under "Absolute Maximum Ratings" may cause permanent damage to the device. These are stress ratings only, and functional operation of the device at these or any other conditions above those indicated in the operational sections of the specifications is not implied. Exposure to absolute maximum ratings conditions for extended periods may affect device reliability.

### ELECTRICAL CHARACTERISTICS

( $+V_S = +6.0V$ ,  $T_A = +25^\circ C$ , unless otherwise noted)

PARAMETER	SYMBOL	CONDITIONS	MAX634			MAX4391			UNITS
			MIN.	TYP.	MAX.	MIN.	TYP.	MAX.	
Supply Voltage (Note 1)	$+V_S$		2.3		16.5	4.0		16.5	V
Supply Current	$I_{IN}$	No External Loads $+V_S = 4.0V$ $+V_S = 16.5V$		70 150	150 500		90 170	250 500	$\mu A$
Output Voltage	$V_{OUT}$	$V_{OUT\ nom} = -5.0V$ $V_{OUT\ nom} = -15.0V$	-5.20 -15.70		-4.80 -14.30	-5.35 -15.85		-4.65 -14.15	V
Line Regulation (Note 4)		$V_{OUT\ nom} = -5.0V$ $V_{IN} = 5.0V$ to 15V			2.0			3.0	% $V_{OUT}$
Load Regulation (Note 4)		$V_{OUT\ nom} = -5.0V$ $+V_S = 4.5V$ , $C_X = 350pF$ $P_{LOAD} = 0mW$ to 75mW $V_{OUT\ nom} = -15.0V$ $+V_S = 4.5V$ , $C_X = 350pF$ $P_{LOAD} = 0mW$ to 75mW			0.4 0.14			0.4 0.14	% $V_{OUT}$
Reference Voltage			1.22	1.25	1.28	1.18	1.25	1.32	V
Switch Current	$I_{SW}$	Pin 5 = 5.0V	75	150		75	150		mA
Switch Leakage Current	$I_{CO}$	Pin 5 = -18V, $+V_S = 6V$		0.01	1.0		0.01	5.0	$\mu A$
Capacitor Charging Current	$I_{CX}$			30			30		$\mu A$
$C_X$ + Threshold Voltage				$+V_S - 0.1$			$+V_S - 0.1$		V
$C_X$ - Threshold Voltage				0.1			0.1		V
Operating Frequency Range (Note 3)	$F_O$		0.1		75	0.1		75	kHz
Low Battery Output Current	$I_{LBD}$	$V_B = 0.4V$ , $V_I = 1.1V$	500	1000		250	600		$\mu A$
Low Battery Output Leakage	$I_{LBDO}$	$V_B = 16.5V$ , $V_I = 1.4V$		0.01	3.0		0.01	5.0	$\mu A$
Low Battery Input Threshold	$V_{LBR}$			1.25			1.25		V
Low Battery Input Bias Current	$I_{LBR}$			0.01	10		0.01	10	nA
Feedback Input Bias Current	$I_{FB}$			0.01	10		0.01	10	nA
Efficiency		Figure 2		80			80		%

**Note 1:** In addition to the Absolute Maximum rating of +18V, the input voltage also must not exceed  $24 - |-V_{OUT}|$ .

**Note 2:** The input voltage limit may be exceeded provided input current is limited to less than 1mA.

**Note 3:** The operating frequency range is guaranteed by design and verified with sample testing.

**Note 4:** Guaranteed by correlation with DC pulse measurements.

# CMOS Micropower Inverting Switching Regulator

**MAX634/MAX4391**

## ELECTRICAL CHARACTERISTICS

(+V<sub>S</sub> = +6.0V, full operating temperature range unless otherwise noted)

PARAMETER	SYMBOL	CONDITIONS	MAX634			MAX4391			UNITS
			MIN.	TYP.	MAX.	MIN.	TYP.	MAX.	
Supply Voltage (Note 5)	+V <sub>S</sub>		2.6		16.5	4.0		16.5	V
Supply Current	I <sub>IN</sub>	No External Loads +V <sub>S</sub> = 4.0V +V <sub>S</sub> = 16.5V			150 500			250 500	μA
Reference Voltage	V <sub>REF</sub>		1.18	1.25	1.32	1.13	1.25	1.36	V
Output Voltage	V <sub>OUT</sub>	V <sub>OUT nom</sub> = -5.0V V <sub>OUT nom</sub> = -15.0V	-5.25 -16.0		-4.75 -14.0	-5.5 -16.5		-4.5 -13.5	V
Line Regulation		V <sub>OUT nom</sub> = -5.0V +V <sub>S</sub> = 5.0V to 15V			3.0			4.0	%V <sub>OUT</sub>
Load Regulation		V <sub>OUT nom</sub> = -5.0V +V <sub>S</sub> = 4.5V, C <sub>X</sub> = 350pF P <sub>LOAD</sub> = 0mW to 75mW V <sub>OUT nom</sub> = -15.0V +V <sub>S</sub> = 4.5V, C <sub>X</sub> = 350pF P <sub>LOAD</sub> = 0mW to 75mW			0.5 0.3			0.5 0.3	%V <sub>OUT</sub>
Switch Leakage Current	I <sub>CO</sub>	Pin 5 = -18V, +V <sub>S</sub> = 6V		0.01	20			30	μA
Low Battery Output Current	I <sub>LBD</sub>	V <sub>B</sub> = 0.4V, V <sub>I</sub> = 1.1V	500			250			μA
Low Battery Output Leakage	I <sub>LBD0</sub>	V <sub>B</sub> = 16.5V, V <sub>I</sub> = 1.4V			3			5	μA

**Note 5:** In addition to the Absolute Maximum rating of +18V, the input voltage also must not exceed 24 - |V<sub>OUT</sub>|.

## Pin Description

PIN	NAME	FUNCTION
1	LBR	Low Battery Detection comparator input. The LBD output, pin 2, sinks current when this pin is below the low battery detector threshold of 1.25V.
2	LBD	The Low Battery Detector output is an open drain N-channel MOSFET which sinks current when the LBR input, pin 1, is below 1.25V.
3	C <sub>X</sub>	An external capacitor connected between this terminal and ground sets the oscillator frequency. 47pF = 40kHz
4	GND	Ground.
5	L <sub>X</sub>	External Inductor output driver. The internal P-channel MOSFET which drives this pin has an output resistance of 8Ω and a peak current rating of 525mA.

PIN	NAME	FUNCTION
6	+V <sub>S</sub>	The positive supply voltage, from +3V to +16.5V (MAX634). The total voltage difference between the negative output voltage and the positive input voltage must be less than 24V.
7	V <sub>REF</sub>	The Voltage REference output is 1.25V, generated by an on-chip bandgap reference.
8	V <sub>FB</sub>	The output voltage is set by an external resistive divider connected to the Voltage Feedback input, pin 8. The MAX634/MAX4391 will pulse the L <sub>X</sub> output whenever the voltage at this terminal is above Ground.

# CMOS Micropower Inverting Switching Regulator

## Typical Operating Characteristics

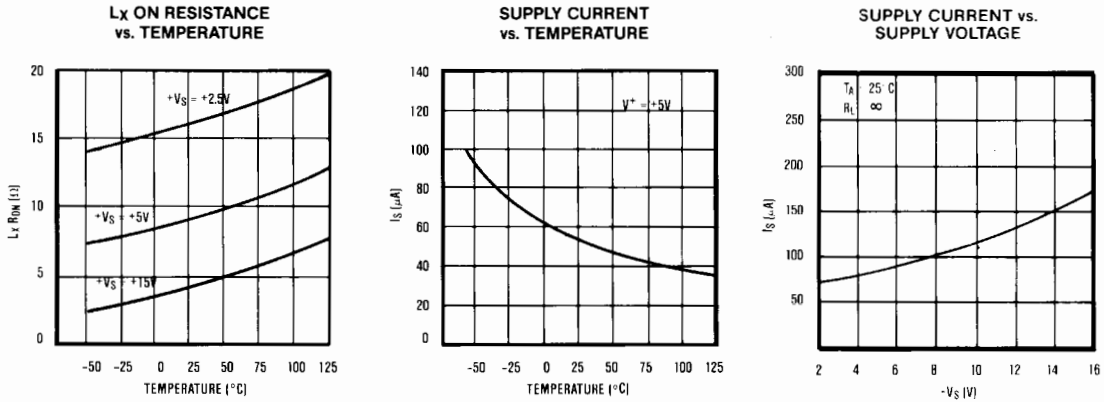

### Detailed Description

#### Principle of Operation

Figure 1 shows a simplified buck-boost voltage inverter, sometimes called an inverting or flyback converter. When the switch is closed a charging current flows through the inductor, creating a magnetic field. When the switch opens, the current continues to flow through the inductor in the same direction as the charging current. Since the switch is now open, the current must flow through the diode, thereby charging the capacitor with a negative voltage. The current linearly decays to zero and the magnetic field collapses as the energy stored in the inductor is transferred to the output filter capacitor.

The MAX634 controls the magnitude of the negative output voltage by turning the switch on and off only when the output voltage has fallen below the desired value.

#### Basic Circuit Operation

Figure 2 shows the standard circuit for converting a positive input voltage into a negative voltage. When the feedback voltage at pin 8 is above ground, the P-channel MOSFET at pin 5 turns on during the next low-going period of the oscillator. The P-channel MOSFET delivers current to the external inductor, storing energy in its magnetic field. When the oscillator output goes high, the P-channel MOSFET turns off, and the "kickback" of the inductor pulls current through diode D1, negatively charging the output filter capacitor, C1. This cycle repeats until the output voltage pulls the feedback input, pin 8, below ground.

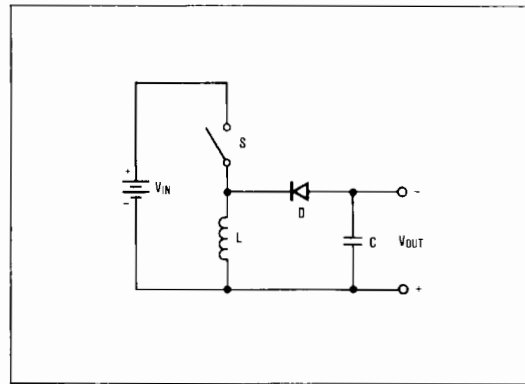

Figure 1. Simplified Voltage Inverter

The NOR gate latch prevents high frequency oscillations by not allowing L<sub>X</sub> to switch repeatedly during an oscillator cycle.

The output voltage is determined by the internal 1.25V reference and the ratio of the resistors R1 and R2.

$$V_{OUT} = 1.25V \times \frac{R1}{R2}$$

Capacitor C1 is the output filter capacitor. The capacitance and ESR (equivalent series resistance) of C1 determine the output ripple. C2 and C3 are bypass capacitors; while C<sub>X</sub> sets the oscillator frequency.

# CMOS Micropower Inverting Switching Regulator

MAX634/MAX4391

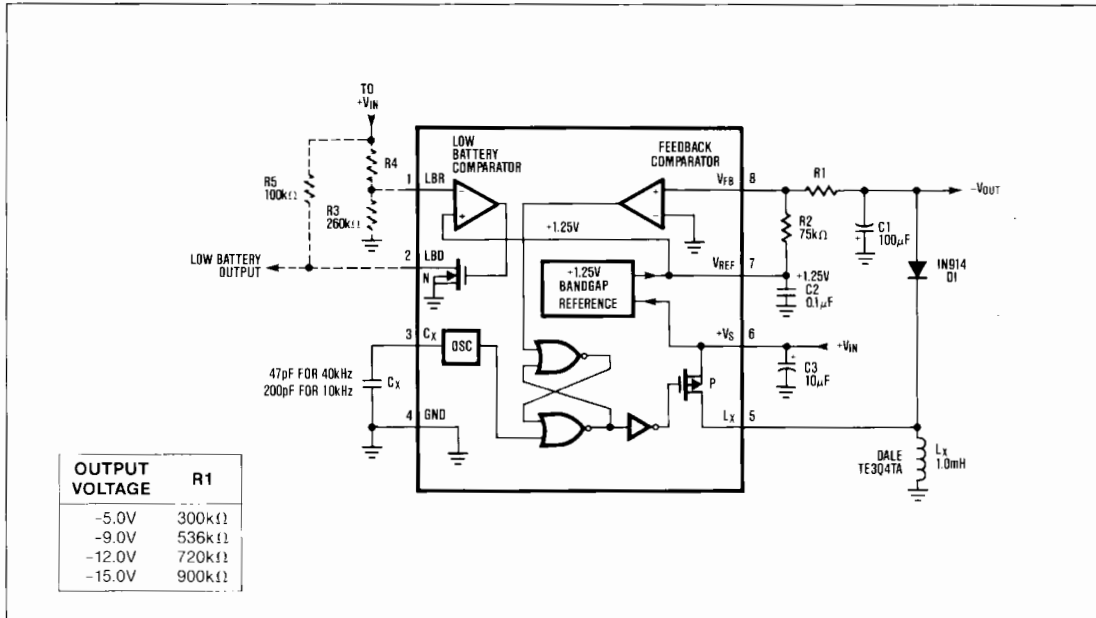

Figure 2. Standard Application Circuit

## Oscillator

The MAX634/MAX4391 oscillator uses only one external component, a capacitor  $C_X$  connected between pin 3 and Ground. A value of 47pF sets the oscillator frequency to approximately 40kHz.

The oscillator can also be externally driven with a CMOS gate which swings from ground to  $+V_S$ . The  $L_X$  output is always off when the  $C_X$  pin is externally driven high.

## Low Battery Detector

The Low Battery Detector (LBD) Output (pin 2, Figure 2) sinks current whenever the input voltage at Low Battery Resistor (pin 1) is less than +1.25V. The LBR input is a high impedance CMOS input, with less than 10nA leakage current. The LBD output is an open drain N-channel MOSFET with about 500Ω of output resistance. The operating voltage of the low battery detector can be adjusted using an external voltage divider as shown in Figure 2. If hysteresis is desired, add a resistor between pins 1 and 2.

$$V_{LOBATT} = 1.25V \times \left(1 + \frac{R4}{R3}\right) \text{ or,}$$

$$R4 = R3 \times \left(\frac{V_{LOBATT}}{1.25V} - 1\right)$$

where  $V_{LOBATT}$  is the operating voltage of the low battery detector, and  $R3$  is usually between 10kΩ and 10MΩ, with a typical value being 470kΩ.

## External Component Selection

### Inductor Value

The available output current from an inverting DC-DC voltage converter is determined by the value of the external inductor, the output voltage, the input voltage, and the operating frequency. The inductor must 1) have the correct inductance, 2) be able to handle the peak currents, and 3) have acceptable series resistance and core losses.

$$L_{MAX} = \frac{(V_{IN} T_{ON})^2 f}{2 P_{OUT}}$$

$$L_{MIN} = \frac{V_{IN} T_{ON}}{I_{MAX}}$$

where  $I_{MAX}$  is the maximum allowable peak  $L_X$  current (525mA).

Contrary to what most people would expect at first glance, reducing the inductor value increases the available output current: lower L increases the peak current, thereby increasing the available power. If the inductance is too high, the MAX634/MAX4391 will not be able to deliver the desired output power,

## CMOS Micropower Inverting Switching Regulator

even with the  $L_X$  output turned on with each oscillator cycle. The available output power can be increased by either decreasing the inductance or by decreasing the frequency. Decreasing the frequency increases the on period of the  $L_X$  output, thereby increasing the peak inductor current, which in turn increases the available output power since the output power is proportional to the square of the peak inductor current.

The most common MAX634 circuit is the buck-boost voltage inverter (Figure 2). When the P-channel output device is on, the current in the inductor linearly rises since:

$$\frac{di}{dt} = \frac{V}{L}$$

At the end of the on period the current is

$$I_{pk} = \frac{V_{IN} T_{on}}{L} = \frac{5V \times 50\mu s}{1mH} = 250mA$$

assuming a 10kHz, 50% duty cycle oscillator and  $+V_S = 5V$

The energy in the coil is:

$$E = \frac{1}{2} L I_{pk}^2 = 31.2\mu J$$

At maximum load this cycle is repeated 10,000 times per second, and the power transferred through the coil is  $10,000 \times 31.2\mu J = 312mW$ . If the output voltage is  $-5V$ , then  $312/5 = 62.5mA$  of output current is available, ignoring losses and component tolerances. In a practical circuit, 50mA of output current is available at  $-5V$ .

The external inductor required by the MAX634/MAX4391 is readily obtained from a variety of suppliers. (See Table 1.)

### Types of Inductors

#### Molded Inductors

These are cylindrically wound coils which look similar to 1 watt resistors. They have the advantages of low cost and ease of handling, but have higher resistance, higher losses, and lower power handling capability than other types.

#### Potted Toroidal Inductors

A typical 1mH, 0.82 ohm potted toroidal inductor (Dale TE-3Q4TA) is 0.685" in diameter by 0.385" high and mounts directly onto a printed circuit board by its leads. Such devices offer high efficiency and mounting ease, but at a somewhat higher cost than molded inductors.

#### Ferrite Cores (Pot Cores)

Pot cores are very popular as switch-mode inductors since they offer high performance and ease of design. The coils are generally wound on a plastic bobbin, which is then placed between two pot core sections. A simple clip to hold the core sections

together completes the inductor. Smaller pot cores mount directly onto printed circuit boards via the bobbin terminals. Cores come in a wide variety of sizes, often with the center posts ground down to provide an air gap. The gap prevents saturation while accurately defining the inductance per turn squared.

Pot cores are suitable for all DC-DC converters, but are usually used in the higher power applications. They are also useful for experimentation since it is easy to wind coils onto the plastic bobbins.

#### Toroidal Cores

In volume production the toroidal core offers high performance, low size and weight, and low cost. They are, however, slightly more difficult for prototyping, in that manually winding turns onto a toroid is more tedious than on the plastic bobbins used with pot cores. Toroids are more efficient for a given size since the flux is more evenly distributed than in a pot core, where the effective cross sectional area differs between the post, side, top and bottom.

Since it is difficult to gap a toroid, manufacturers produce toroids using a mixture of ferromagnetic powder (typically iron or Mo-Permalloy powder) and a binder. The permeability is controlled by varying the amount of binder, which changes the effective gap between the ferromagnetic particles. Mo-Permalloy powder (MPP) cores have lower losses and are recommended for the highest efficiency, while iron powder cores are lower cost.

Table 1. Coil and Core Manufacturers

MANUFACTURER	TYPICAL PART #	DESCRIPTION
<b>MOLDED INDUCTORS</b>		
Dale	IHA-104	500 $\mu$ H, 0.5 ohms
Caddell-Burns	6860-19	330 $\mu$ H, 0.33 ohms
TRW	LL-500	500 $\mu$ H, 0.75 ohms
<b>POTTED TOROIDAL INDUCTORS</b>		
Dale	TE-3Q4TA	1mH, 0.82 ohms
TRW	MH-1	600 $\mu$ H, 1.9 ohms
Torotei Prod.	PT 53-18	500 $\mu$ H, 5 ohms
<b>FERRITE CORES AND TOROIDS</b>		
Allen Bradley	T0451S100A	Tor. Core, 500nH/T <sup>2</sup>
Siemens	B64290-K38-X38	Tor. Core, 4 $\mu$ H/T <sup>2</sup>
Magnetics	555130	Tor. Core, 53nH/T <sup>2</sup>
Stackpole	57-3215	Pot Core, 14mm x 8mm
Magnetics	G-41408-25	Pot Core, 14 x 8, 250nH/T <sup>2</sup>

**Note 1:** This list does not constitute an endorsement by Maxim Integrated Products and is not intended to be a comprehensive list of all manufacturers of these components.

## CMOS Micropower Inverting Switching Regulator

### External Diode

In most MAX634 circuits the inductor current returns to zero before  $L_X$  turns on for the next output pulse. This allows the use of slow turn-off diodes. On the other hand, the diode current abruptly goes from zero to full peak current each time  $L_X$  switches off (Figure 2, D1). To avoid excessive losses during turn-on, the diode must have a fast turn-on time.

The 1N914 or 1N4148 is suitable for low power applications. The 1N5817 series of Schottky diodes or their equivalent are suitable for higher power applications. Rectifier diodes such as the 1N4001 series are unacceptable since their slow turn-on results in excessive losses.

### Filter Capacitor

The output filter capacitor ( $C_1$  in Figure 2) stores the energy delivered by the inductor, and delivers current to the load. The output voltage ripple is directly affected by the capacitance and the equivalent series resistance (ESR) of the output filter capacitor.

The output voltage ripple has two components, with approximately  $90^\circ$  phase difference. One ripple component is created by the change in stored charge in the capacitor with each output pulse. The other ripple component is the product of the capacitor charge/discharge current times the ESR (effective series resistance) of the capacitor. With low cost aluminum electrolytic capacitors, the ESR produced ripple is generally larger than the ripple from the change in charge.

$$V_{ESR} = I_{pk} \times ESR \text{ (Volts P-P)}$$

$$= \left( \frac{V_{IN}}{2LF} \right) \times ESR \text{ (Volts P-P)}$$

where  $V_{IN}$  is the input voltage to the coil,  $L$  is the inductance of the coil,  $f$  is the oscillator frequency, and ESR is the equivalent series resistance of the output filter capacitor.

The output ripple resulting from the change in charge on the filter capacitor is:

$$V_{dQ} = \frac{Q}{C} \text{ where: } Q = t_{DIS} \times \frac{I_{peak}}{2}$$

$$\text{and: } I_{peak} = t_{CHG} \times \frac{V_{IN}}{L}$$

$$V_{dQ} = \frac{V_{IN}(t_{CHG})(t_{DIS})}{2LC}$$

where  $t_{CHG}$  and  $t_{DIS}$  are the charge and discharge times for the inductor ( $1/(2f)$  can be used for nominal calculations).

### Oscillator Capacitor, $C_X$

The oscillator capacitor can be a low cost ceramic capacitor. If the circuit will be operated over a wide temperature range, an capacitor with a low temperature coefficient of capacitance should be used.

The value of  $C_X$  can be calculated using the formula:

$$C_X = \frac{2.14 \times 10^{-6}}{f} - C_{INT}$$

where  $f$  is the desired operating frequency in Hertz, and  $C_{INT}$  is the sum of the stray capacitance on the  $C_X$  pin and the internal capacitance of the package. The internal capacitance is about 1pF for the plastic package and 3pF for the CERDIP package. Typical stray capacitance is about 3pF for normal printed circuit board layouts, but will be significantly higher if a socket is used.

### Application Hints

#### Inductor Saturation

When using off-the-shelf inductors, make sure that the peak current rating is observed. When designing your own inductors, observe the core manufacturer's Ampere-turns or NI ratings. Failure to observe the peak current or NI ratings may lead to saturation of the inductor, especially in circuits with external current boosting transistors. Inductor saturation leads to very high current levels through the external boost transistors, causing excessive power dissipation, poor efficiency, and possible damage to the inductor and the external transistor.

Test for saturation by applying the maximum load, the maximum input voltage, and (for a safety margin) lowering the clock frequency by 25%. Monitor the inductor current using a current probe. The normal inductor current waveform is a sawtooth with a linear current ramp. Saturation creates a nonlinear current waveform with a very rapid increase in current once the inductor saturates. It is this rapid current increase and the resultant high peak currents that can damage the inductor and the external boost transistor.

#### Bypassing and Compensation

The high operating current pulses in the  $L_X$  output and the external inductor can cause erratic operation unless the MAX4391/MAX634 is properly bypassed. Connect a  $10\mu\text{F}$  bypass capacitor directly across the MAX4391 between pin 6 ( $+V_S$ ) and pin 4 (Ground) to minimize the inductance and high frequency impedance of the power source. Make sure that the high current ground return path of the inductor does not cause a voltage drop in the MAX4391 ground line.

## CMOS Micropower Inverting Switching Regulator

The reference voltage output, pin 7, should also be bypassed to ground to avoid coupling to the high current path that includes the L<sub>x</sub> output, the inductor, and its ground return.

With light loads, coupling from the high power circuit into the control circuitry may cause the output pulses to occur in bursts, thereby increasing low frequency ripple and degrading the line and load regulation. Normal operation with evenly distributed output pulses can be restored by adding a 100pF to 10nF compensation capacitor across the feedback resistor, R1. Minimizing the stray capacitance on the V<sub>FB</sub> terminal will often eliminate the need for this compensation capacitor.

### Typical Applications

#### -5V Output Regulated Voltage Inverter

The standard circuit in Figure 2 will deliver 50mA at -5V. Efficiency is 85% when using a low loss pot core or toroidal inductor such as the Dale TE3Q4TA series. Using a low cost molded inductor with several ohms series resistance reduces the efficiency to 70%.

#### -12V and -15V Output DC-DC Inverters

The circuit of Figure 2 can also be used for -12V or -15V outputs by simply changing the value of R1 in the feedback network using the formula

$$R1 = \frac{V_{OUT} R2}{1.25V}$$

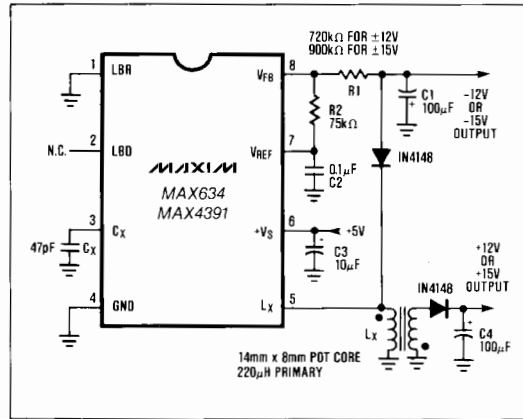

Figure 3. Dual Output, +12V or ±18V DC-DC Converter

### Dual Output, ±12V or ±15V DC-DC Converters

The buck-boost configuration of the MAX634 is well suited for dual output DC-DC converters. As shown in Figure 3, all that is needed is a second winding on the inductor. Typically, this second winding is bifilar (primary and secondary are wound simultaneously using two wires in parallel). The inductor core is usually a toroid or a pot core, see Table 1.

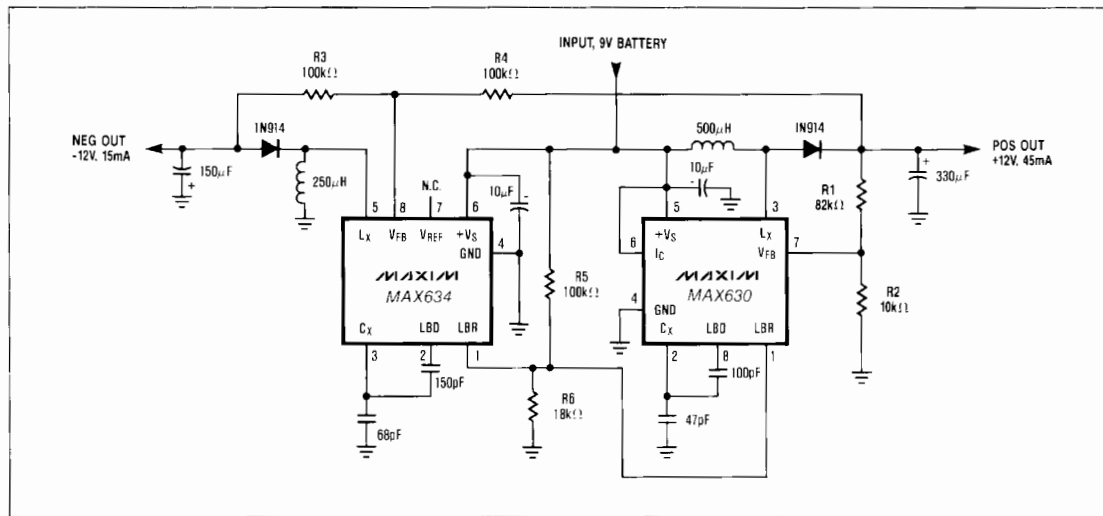

Figure 4. ±12V Dual Tracking Regulator



## CMOS Micropower Inverting Switching Regulator

The negative output voltage is fully regulated by the MAX634. The positive voltage is semi-regulated, and will vary slightly with load changes on either the positive or negative outputs. See the MAX630 data sheet for a similar circuit with a fully regulated positive output and a semi-regulated negative output. If both outputs must be fully regulated use both a MAX634 and a MAX630, as shown in Figure 4.

### Voltage Inverter

In Figure 5, the negative output voltage tracks the positive input voltage. This circuit performs the same function as Maxim's ICL7660, but with better output regulation and higher output current capability. With the circuit components shown, Figure 5 will deliver approximately 50mA at -9V when the input is +9V, and about 30mA at -5V when the input is +5V.

Input voltage tracking is achieved by using the positive input voltage as the reference instead of the onboard bandgap reference.

The output voltage is set by the input voltage, R1, and R2 as follows:

$$V_{OUT} = -\frac{R2}{R1} \times V_S$$

### Low Power Shutdown

Unlike the MAX630, the MAX634 and MAX4391 do not have a logic level shutdown pin, but a low power mode can easily be implemented as shown in Figure 6. Since the operating current is only 250µA maxi-

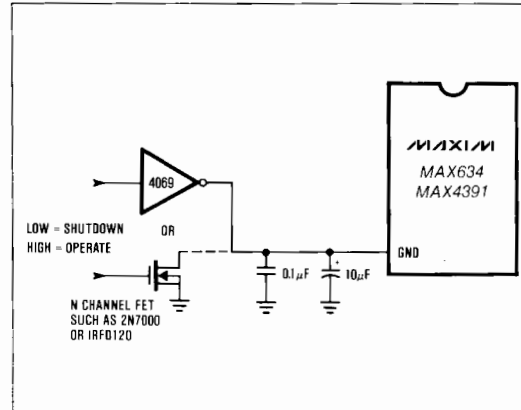

Figure 6. Low Power Shutdown

mum, the GND pin can be driven directly by a CMOS gate or N-channel FET. Drive GND low for normal operation; let it float or drive it high to enter the low power shutdown mode. In low power shutdown the MAX634 circuit draws only the leakage current of the L<sub>x</sub> output.

The Ground pin should be well bypassed and any voltage drop across the CMOS gate adds to the reference voltage, slightly increasing the regulated output voltage.

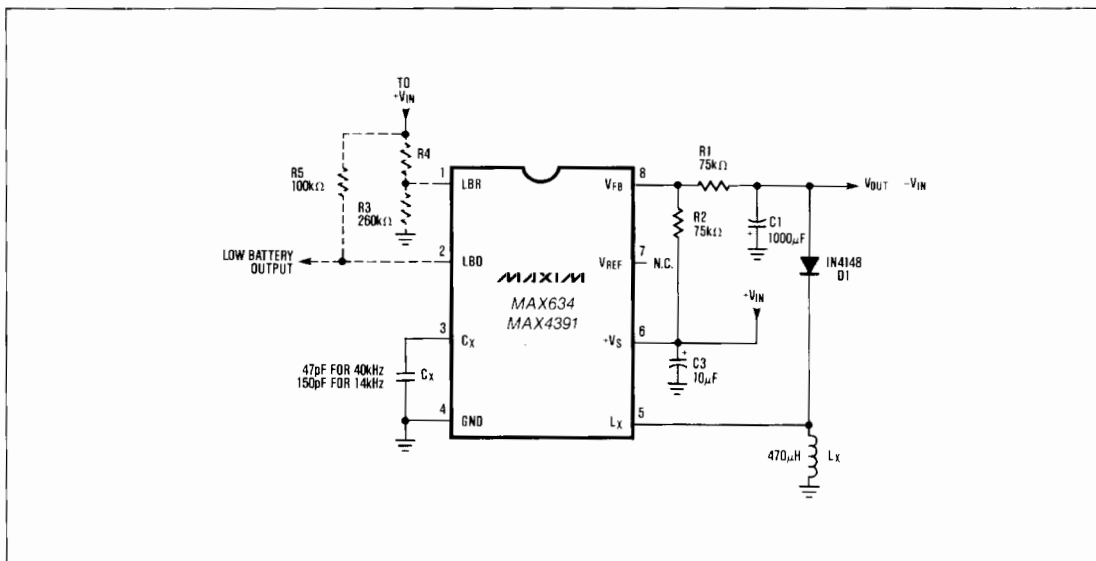

Figure 5. Regulated Voltage Inverter

MAX634/MAX4391

## CMOS Micropower Inverting Switching Regulator

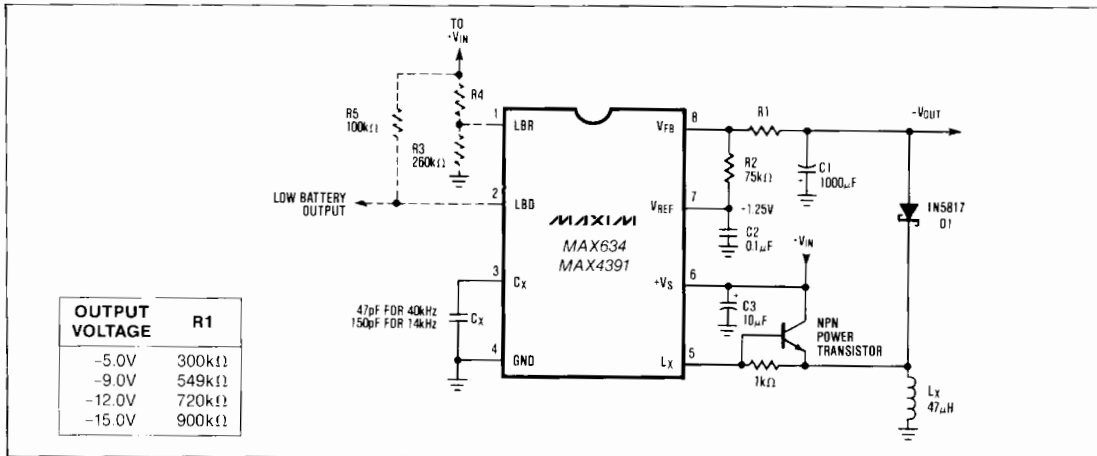

Figure 7. Boosting Output Power With External NPN Power Transistor

### Boosting Output Power With External Power Devices

The MAX634 and MAX4391 are limited to a maximum switch current of 525mA. If higher current, or output resistance less than the 6 ohms of the MAX634 is required, the circuits of Figures 7, 8, or 9 can be used.

The circuit of Figure 7 uses an NPN bipolar transistor to boost the output current. All of the NPN transistor base current is used to drive the inductor, but the voltage drop across the transistor will be approximately 0.7V.

The circuit of Figure 8 uses a low resistance N-channel MOSFET in a transformer coupled voltage inverter circuit. This circuit has the advantage that a

positive output voltage can also be obtained by simply adding a diode and an output filter capacitor. The -15V output is fully regulated for both line and load variations; the +20V output voltage will vary with changes in load on either the +20V or -15V output, as well as changes in the +5V input. This variation is normally less than 10%.

### High Output Voltage

The circuit in Figure 9 converts any positive voltage from +3V to +16V to any desired output voltage, as long as the voltage breakdown of the external P-Channel MOSFET is not exceeded. This circuit is also useful for generating a high power, high efficiency -12V or -15V output using a simple one winding coil.

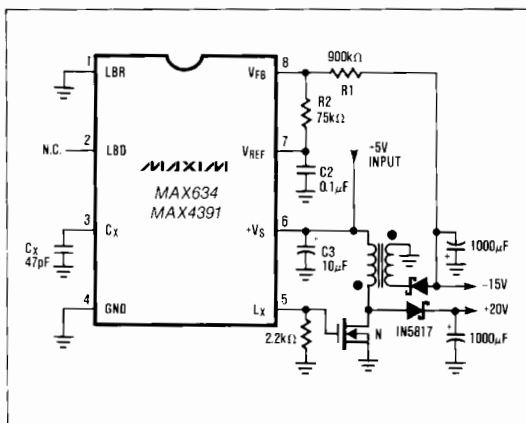

Figure 8. High Power +5V to -15V DC-DC Converter

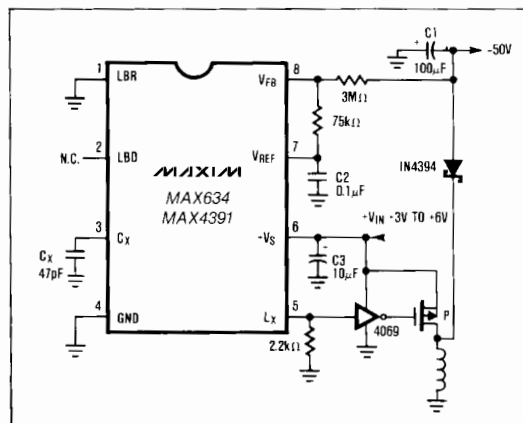

Figure 9. Boosting Voltage External P-Channel MOSFET

## CMOS Micropower Inverting Switching Regulator

### Operating with Wide Input Voltage Range

The available output power varies as the square of the input voltage. The Low Battery Detector can compensate for a reduction in input voltage by lowering the oscillator frequency, as shown in Figure 10. With the values shown, the oscillator frequency is 40kHz when the input voltage is above 6V. When the input falls below 6V, the Low Battery Detector (LBD) output goes low, placing the 100pF capacitor in parallel with  $C_X$ , reducing the oscillator frequency to 14kHz. This increases the available output power by a factor of 3.

This circuit can be used with any of the other application circuits in this data sheet.

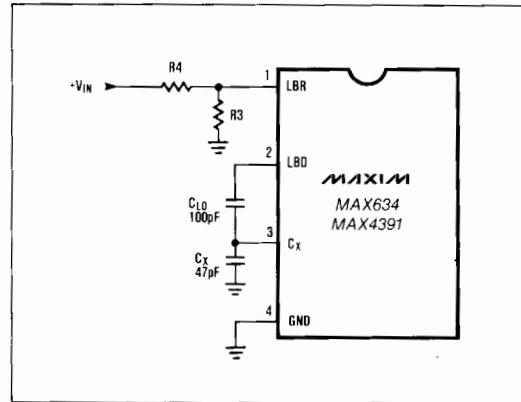
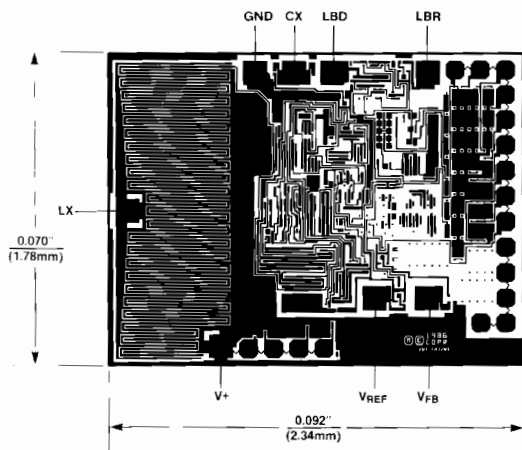

Figure 10. Wide Input Voltage Range Operation with Variable Frequency Oscillator.

MAX634/MAX4391

### Chip Topography



# CMOS Micropower Inverting Switching Regulator

**Table 2. Maxim DC-DC Converters**

DEVICE	DESCRIPTION	INPUT VOLTAGE	OUTPUT VOLTAGE	COMMENTS
ICL7660	Charge Pump Voltage Inverter	1.5V to 10V	$-V_{IN}$	Not regulated
MAX4193	DC-DC Boost Converter	2.4V to 16.5V	$V_{OUT} > V_{IN}$	RC4193 2nd source
MAX630	DC-DC Boost Converter	2.0V to 16.5V	$V_{OUT} > V_{IN}$	Improved RC4191 2nd source
MAX631	DC-DC Boost Converter	1.5V to 5.6V	+5V	Only 2 external components
MAX632	DC-DC Boost Converter	1.5V to 12.6V	+12V	Only 2 external components
MAX633	DC-DC Boost Converter	1.5V to 15.6V	+15V	Only 2 external components
MAX4391	DC-DC Voltage Inverter	4V to 16.5V	up to -20V	RC4391 2nd source
MAX634	DC-DC Voltage Inverter	2.3V to 16.5V	up to -20V	Improved RC4391 2nd source
MAX635	DC-DC Voltage Inverter	2.3V to 16.5V	-5V	Only 3 external components
MAX636	DC-DC Voltage Inverter	2.3V to 16.5V	-12V	Only 3 external components
MAX637	DC-DC Voltage Inverter	2.3V to 16.5V	-15V	Only 3 external components
MAX638	DC-DC Voltage Stepdown	3V to 16.5V	$V_{OUT} < V_{IN}$	Only 3 external components
MAX641	High Power Boost Converter	1.5V to 5.6V	+5V	Drives external MOSFET
MAX642	High Power Boost Converter	1.5V to 12.6V	+12V	Drives external MOSFET
MAX643	High Power Boost Converter	1.5V to 15.6V	+15V	Drives external MOSFET

## Package Information

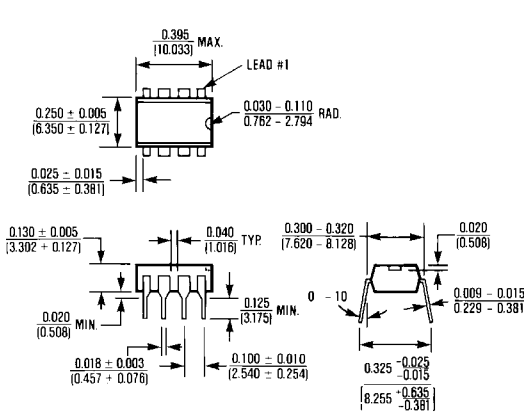

**8 Lead Plastic DIP (PA)**  
 $\theta_{JA} = 160^{\circ}\text{C/W}$   
 $\theta_{JC} = 75^{\circ}\text{C/W}$

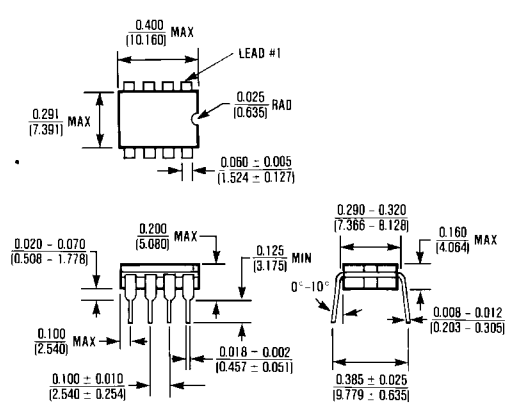

**8 Lead Cerdip (JA)**  
 $\theta_{JA} = 125^{\circ}\text{C/W}$   
 $\theta_{JC} = 55^{\circ}\text{C/W}$

Maxim cannot assume responsibility for use of any circuitry other than circuitry entirely embodied in a Maxim product. No circuit patent licenses are implied. Maxim reserves the right to change the circuitry and specifications without notice at any time.

12 **Maxim Integrated Products, 120 San Gabriel Drive, Sunnyvale, CA 94086 (408) 737-7600**