

Mini Vibration Motor

Operating conditions

Items	Specifications	Condition & Remarks
Rated voltage	3.0V DC	
Rated load	Counter weight	As specified in the outline drawing.
Rotation	C.W. (clockwise)	
Motor position	All positions	
Operating voltage	2.2~3.6V DC	
Operating conditions	-30 ~ 70°C ordinary humidity	No condensation of moisture.
Storage conditions	-40 ~ 80°C, ordinary humidity	No condensation of moisture.

Mechanical specifications

Items	Specifications	Condition & Remarks
Configuration	As specified in outline drawing	
Appearance	There shall be no evidence of mechanical damage and shall not have inadequate corrosion, etc.	Visual examination: Inspection carried out on samples.
Shaft end play	0.05 mm ~ 0.2 mm Max	
Mass	1.23g approx.	
Holding strength of vibration weight	49N (5kgf)	

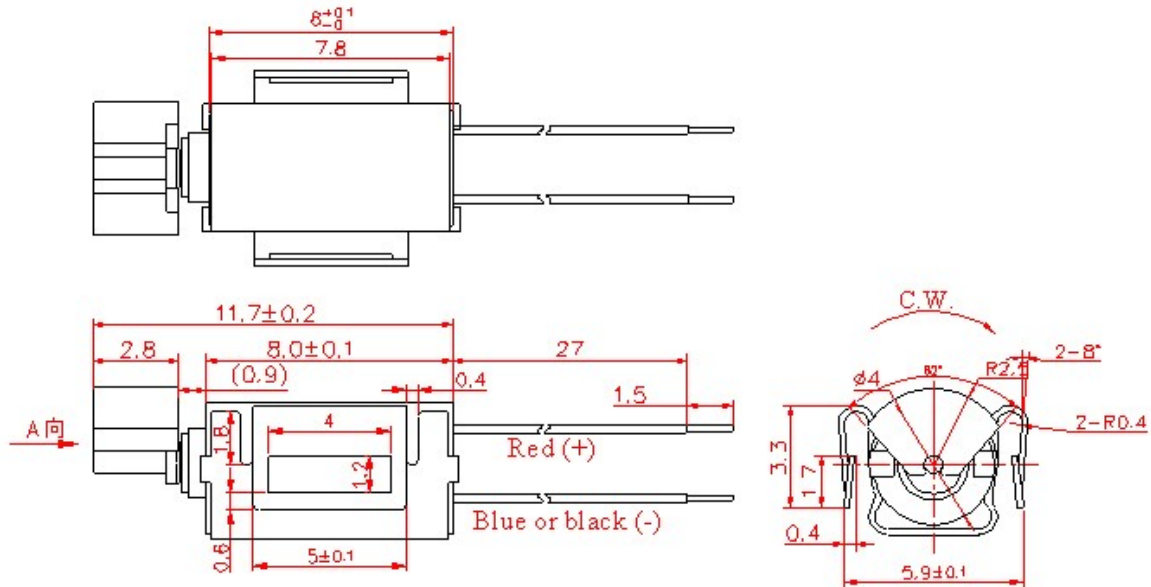

Performance and characteristics

Items	Specifications	Condition & Remarks
Rated speed	12,000 @ 2,500 rpm	At rated voltage and rated load (vibration weight).
Rated current	90mA max	
Stall current	120mA max	At rated voltage.
Starting voltage	2.0V DC max	At rated load (vibration weight) any position of rotor.
Insulation resistance	1MΩ min	At DC 100V between the lead wires and motor body.
Terminal resistance	2Ω approx.	At 20c
Mechanical noise	50db (A) max	
Measured at rated voltage and rated load (vibration weight). Background noise: 28db (A) max. @ 10cm. Measuring instruments: B & K. The weight of jig: 700g.		

Caution and Matters

8-1 Warnings: In a motor near the end its life, or under breakdown conditions, short circuits can develop between commutator segments. Uncontrolled voltage may then leak into the power source circuit. Motors may overheat or fail if run continuously with its rotor locked condition or under excessive loads.

8-2 Destructive atmospheres: Do not use and store the motor in the corrosive gas atmosphere (H₂S, SO₂, NO₂, Cl₂, etc.), or substances that can emit toxic gases, such as organic silicon, cyanide, formalin, or phenol compounds. The motor may get serious damages.

8-3 Condensation: Condensation on the electrical circuits can destroy the motor or control circuits. Monitor the environment and undertake measures to prevent condensation, such as installing condensation sensors to cut power when necessary.

8-4 Be aware of the following factors and perform necessary tests to check a motor capability to adopt with your mechanism and applications: Motor life, electric noise, mechanical noise, vibration, static-electrical noise resistance, power-source noise resistance, drift of rpm, electrical resonance between control circuit and motor, mechanical resonance between subassembly and motor malfunction due to motor noise, electrical magnetic interference, malfunction due to magnetic flux leakage, destruction due to lightning-related power surge, grounding.

8-5 Some particular plastic materials can crack and fail after exposure to motor bearing oil. Perform test the motor in/on the subassembly to check the influence of the oiled plastic parts.

8-6 Avoid connecting a serial resistor to the motor if at all possible, as this can negatively affect reliability. If this is unavoidable, keep resistance as low as possible and test thoroughly for reliability before using.

8-7 When testing for UL, CSA or other safety standards, apply for approval for the entire subassembly.

8-8 Do not store motors under conditions of extreme temperatures or high humidity, or for longer than six months even room conditions. When removing out of packaging after storage, take precautions to prevent condensation.

8-9 Connections: Complete soldering operations within three seconds to prevent damage to leads and terminals. Make sure that the soldering tip does not exceed 350c. Be gentle with terminals; dents or pressure on them can lock up the motor.

8-10 Please consults us in advance when design considerations call for forcefully stalling the motor using a short circuit at the terminal or reverse voltage. Such operations can shorten product life.