

GAS SENSOR *MQ-303A* for ALCOHOL DETECTION

- * High sensitivity
- * Low power consumption
- * Miniature-size

The MQ-303A is a tin dioxide semiconductor gas sensor which has a high sensitivity to alcohol with quick response speed. This model is suitable for alcohol detection such as portable breath alcohol checker or ignition locking system in automobiles.

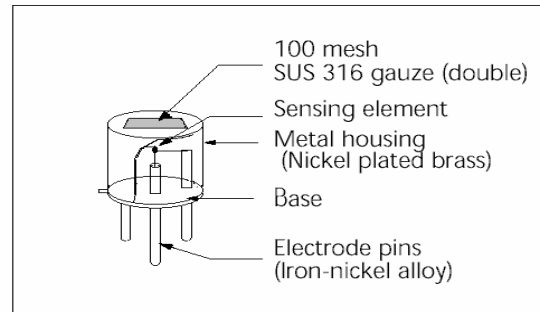

Fig 1a. Configuration

Structure

Gas sensitive semiconductor material is a mini bead type and a heater coil and electrode wire are embedded in the element. The sensing element is installed in the metal housing which uses double stainless steel mesh (100 mesh) in the path of gas flow. The mesh is an anti-explosion feature (Fig 1).

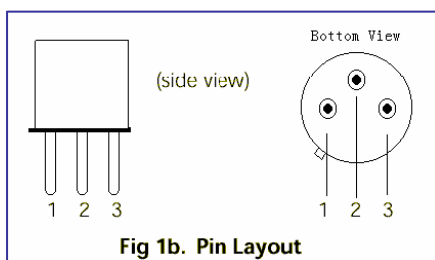

Fig 1b. Pin Layout

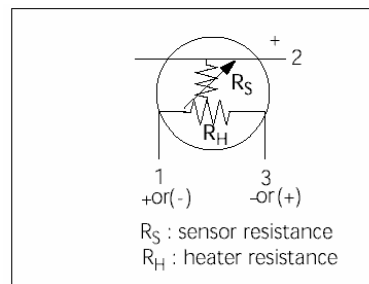

Fig 1c. Equivalent circuit

Operating conditions

Fig 2 shows the standard operating circuit for this model. The change of the sensor resistance (R_S) is obtained as the change of the output voltage across the fixed or variable resistor (R_L). In order to obtain the best performance and specified characteristics, the values of the heater voltage (V_H) circuit voltage (V_C) and load resistance (R_L) must be within the range of values given in the standard operating conditions shown in the Specification table on the next page. Generally, the sensor enters into normal working conditions after several minutes' preheating. If you connect the sensor heater with a high voltage $2.2 \pm 0.20V$ for 5-10 sec before normal testing, the sensor shall stabilize and enter into normal working conditions quickly.

Sensitivity characteristics

Fig 3 shows the sensitivity characteristics curves of the MQ-303A (typical data). Sensitivity characteristics of the gas sensors are expressed by the relationship between the sensor resistance and gas concentration. The sensor resistance decreases with an increase of gas concentration based on a logarithmic function.

Structure and Dimensions:

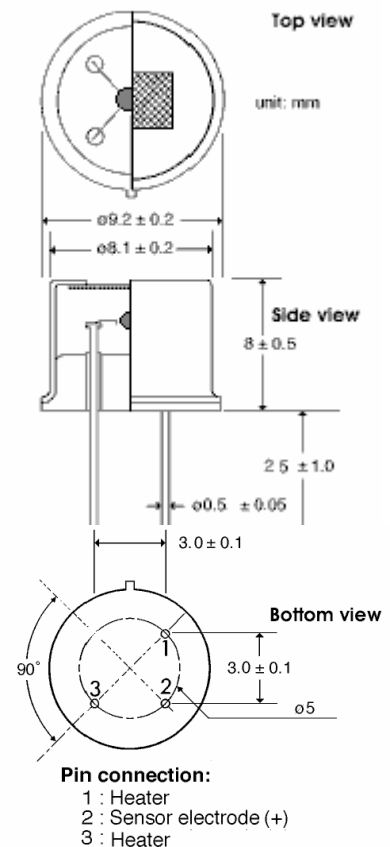

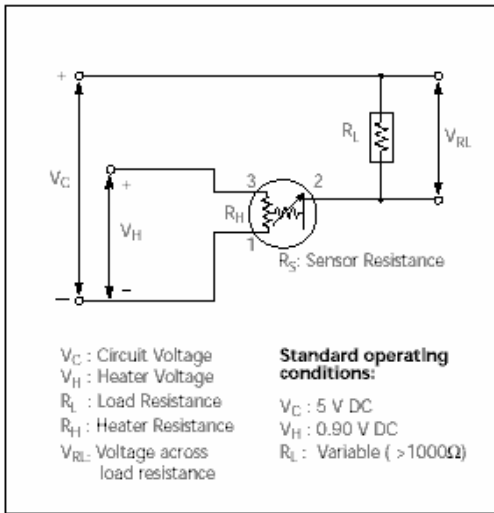

Fig 2. Standard circuit

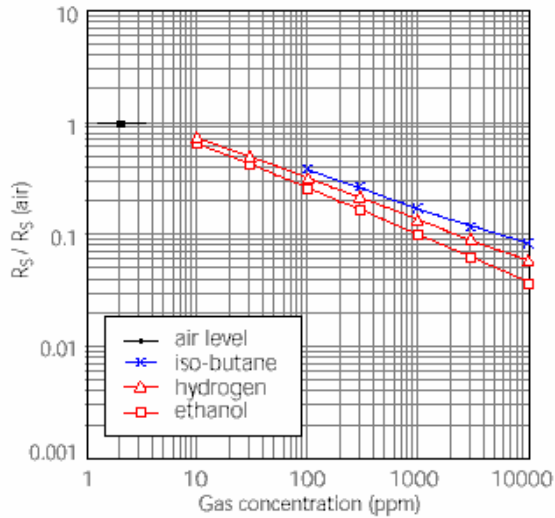

Fig 3. Sensitivity characteristics

A. Standard Operating conditions

Symbol	Parameter	Specification	Conditions etc.
V_H	Heater voltage	1.0V ± 0.10V	AC or DC
V_C	Circuit voltage	Less than 6 V	DC (polarity is important)
R_L	Load resistance	Variable (> 47 Ω)	$P_S < 10 \text{ mW}$
R_H	Heater resistance	3.8 Ω ± 0.5 Ω	at room temperature
I_H	Heater current	Less than 130 mA	$I_H = V_H / R_H$ (typical value)
P_H	Heater power consumption	120 mW	$P_H = V_H^2 / R_H$ (typical value)
P_S	Power dissipation of sensing element	Less than 10 mW	$P_S = (V_C - V_{RL})^2 / R_S$

B. Environmental conditions

Symbol	Parameter	Specification	Conditions etc.
T_{ao}	Operating temperature	-20 °C to 50 °C	Recommended range
T_{as}	Storage temp	-20 °C to 70 °C	
RH	Relative humidity	Less than 95% RH	
(O ₂)	Oxygen concentration	21% ± 1%(Standard condition)	Absolute minimum level: more than 18%
The sensitivity characteristics are influenced by the variation in oxygen concentration.			

C. Sensitivity characteristics

Model	MQ-303A (tentative specifications)		
Symbol	Parameter	Specification	Conditions etc.
R_s	Sensor resistance	(20kΩ to 200 kΩ)	at ethanol 300 ppm
?	Sensitivity	(0.50 ± 0.15)	R_s (at ethanol 300 ppm) / R_s (at ethanol 50 ppm)
Standard Test Conditions: Temp: 20 °C ± 2 °C V_C : 5.0 V ± 1% Humidity: 65% ± 5% V_H : 0.9 V ± 1% (in clean air) R_L : 50K ± 5% Pre-heating time: more than 48 hours			

D. Mechanical characteristics

Items	Conditions	Specifications
Vibration	Frequency: 100 cpm Vertical amplitude: 4 mm Duration: 1 hour	Should satisfy the specifications shown in the sensitivity characteristics.
Shock	Acceleration: 100G Number of impacts: 5 times	