

**Unidirectional and bidirectional
Transient Voltage Suppressor Diodes**

**Unidirektionale und bidirektionale
Spannungs-Begrenzer-Dioden**

Version 2004-10-01

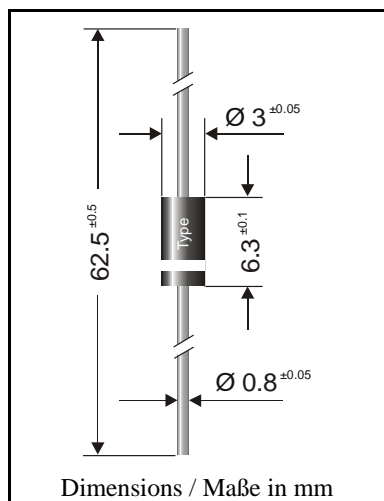

Peak pulse power dissipation Impuls-Verlustleistung	600 W
Nominal breakdown voltage Nominale Abbruch-Spannung	6.8...520 V
Plastic case Kunststoffgehäuse	DO-15 (DO-204AC)
Weight approx. – Gewicht ca.	0.4 g
Plastic material has UL classification 94V-0 Gehäusematerial UL94V-0 klassifiziert	
Standard packaging taped in ammo pack Standard Lieferform gegurtet in Ammo-Pack	see page 16 siehe Seite 16

For bidirectional types (suffix “C” or “CA”), electrical characteristics apply in both directions.
Für bidirektionale Dioden (Suffix “C” oder “CA”) gelten die el. Werte in beiden Richtungen.

Maximum ratings and Characteristics

Kenn- und Grenzwerte

Peak pulse power dissipation (10/1000 µs waveform) Impuls-Verlustleistung (Strom-Impuls 10/1000 µs)	$T_A = 25^\circ\text{C}$	P_{PPM}	600 W ¹⁾
Steady state power dissipation Verlustleistung im Dauerbetrieb	$T_L = 75^\circ\text{C}$	$P_{M(AV)}$	5 W
Peak forward surge current, 60 Hz half sine-wave Stoßstrom für eine 60 Hz Sinus-Halbwellen	$T_A = 25^\circ\text{C}$	I_{FSM}	100 A ²⁾
Operating junction temperature – Sperrschichttemperatur Storage temperature – Lagerungstemperatur		T_j T_s	- 50...+175°C - 50...+175°C
Max. instantaneous forward voltage Augenblickswert der Durchlaßspannung	$I_F = 50\text{ A}$	$V_{BR} \leq 200\text{ V}$ $V_{BR} > 200\text{ V}$	$V_F < 3.5\text{ V}^3)$ $V_F < 5.0\text{ V}^3)$
Thermal resistance junction to ambient air Wärmewiderstand Sperrschicht – umgebende Luft		R_{thA}	< 30 K/W ²⁾
Thermal resistance junction to lead Wärmewiderstand Sperrschicht – Anschlußdraht		R_{thL}	< 15 K/W

¹⁾ Non-repetitive pulse see curve $I_{PPM} = f(t_r) / P_{PPM} = f(t_r)$
Höchstzulässiger Spitzenwert eines einmaligen Impulses, siehe Kurve $I_{PPM} = f(t_r) / P_{PPM} = f(t_r)$
²⁾ Unidirectional diodes only – Nur für unidirektionale Dioden

Maximum ratings
Grenzwerte

Type Typ	Breakdown voltage at $I_T = 1$ mA Abbruch-Spanng. bei $I_T = 1$ mA *) at / bei $I_T = 10$ mA		Stand-off voltage Sperrspg. V_{WM} [V]	Max. rev. current Max. Sperrstrom at / bei V_{WM} I_D [μ A]	Max. clamping voltage Max. Begrenzerspanng. at / bei I_{PPM} (10/1000 μ s) V_C [V] I_{PPM} [A]	
	V_{BR} [V]					
P6KE6.8	6.8 \pm 10%	6.12...7.48 *)	5.5	1000	10.8	58.0
P6KE6.8A	6.8 \pm 5%	6.45...7.14 *)	5.8	1000	10.5	60.0
P6KE7.5	7.5 \pm 10%	6.75...8.25 *)	6.0	500	11.7	53.0
P6KE7.5A	7.5 \pm 5%	7.13...7.88 *)	6.4	500	11.3	55.0
P6KE8.2	8.2 \pm 10%	7.38...9.02 *)	6.6	200	12.5	50.0
P6KE8.2A	8.2 \pm 5%	7.79...8.61 *)	7.0	200	12.1	52.0
P6KE9.1	9.1 \pm 10%	8.19...10.0	7.3	50	13.8	45.0
P6KE9.1A	9.1 \pm 5%	8.65...9.55	7.7	50	13.4	47.0
P6KE10	10 \pm 10%	9.0...11.0	8.1	10	15.0	42.0
P6KE10A	10 \pm 5%	9.5...10.5	8.5	10	14.5	43.0
P6KE11	11 \pm 10%	9.9...12.1	8.9	5	16.2	38.0
P6KE11A	11 \pm 5%	10.5...11.6	9.4	5	15.6	40.0
P6KE12	12 \pm 10%	10.8...13.2	9.7	5	17.3	36.0
P6KE12A	12 \pm 5%	11.4...12.6	10.2	5	16.7	37.0
P6KE13	13 \pm 10%	11.7...14.3	10.5	5	19.0	33.0
P6KE13A	13 \pm 5%	12.4...13.7	11.1	5	18.2	34.0
P6KE15	15 \pm 10%	13.5...16.5	12.1	5	22.0	28.0
P6KE15A	15 \pm 5%	14.3...15.8	12.8	5	21.2	29.0
P6KE16	16 \pm 10%	14.4...17.6	12.9	5	23.5	26.0
P6KE16A	16 \pm 5%	15.2...16.8	13.6	5	22.5	28.0
P6KE18	18 \pm 10%	16.2...19.8	14.5	5	26.5	23.0
P6KE18A	18 \pm 5%	17.1...18.9	15.3	5	25.5	25.0
P6KE20	20 \pm 10%	18.0...22.0	16.2	5	29.1	21.0
P6KE20A	20 \pm 5%	19.0...21.0	17.1	5	27.7	22.0
P6KE22	22 \pm 10%	19.8...24.2	17.8	5	31.9	19.0
P6KE22A	22 \pm 5%	20.9...23.1	18.8	5	30.6	20.0
P6KE24	24 \pm 10%	21.6...26.4	19.4	5	34.7	18.0
P6KE24A	24 \pm 5%	22.8...25.2	20.5	5	33.2	19.0
P6KE27	27 \pm 10%	24.3...29.7	21.8	5	39.1	16.0
P6KE27A	27 \pm 5%	25.7...28.4	23.1	5	37.5	16.8
P6KE30	30 \pm 10%	27.0...33.0	24.3	5	43.5	14.0
P6KE30A	30 \pm 5%	28.5...31.5	25.6	5	41.4	15.0
P6KE33	33 \pm 10%	29.7...36.3	26.8	5	47.7	13.0
P6KE33A	33 \pm 5%	31.4...34.7	28.2	5	45.7	13.8
P6KE36	36 \pm 10%	32.4...39.6	29.1	5	52.0	12.0
P6KE36A	36 \pm 5%	34.2...37.8	30.8	5	49.9	12.6
P6KE39	39 \pm 10%	35.1...42.9	31.6	5	56.4	11.1
P6KE39A	39 \pm 5%	37.1...41.0	33.3	5	53.9	11.6
P6KE43	43 \pm 10%	38.7...47.3	34.8	5	61.9	10.0
P6KE43A	43 \pm 5%	40.9...45.2	36.8	5	59.3	10.6
P6KE47	47 \pm 10%	42.3...51.7	38.1	5	67.8	9.2
P6KE47A	47 \pm 5%	44.7...49.4	40.2	5	64.8	9.7
P6KE51	51 \pm 10%	45.9...56.1	41.3	5	73.5	8.5
P6KE51A	51 \pm 5%	48.5...53.6	43.6	5	70.1	8.9

Maximum ratings

Grenzwerte

Type Typ	Breakdown voltage at $I_T = 1\text{ mA}$ Abbruch-Spanng. bei $I_T = 1\text{ mA}$		Stand-off voltage Sperrspg. V_{WM} [V]	Max. rev. current Max. Sperrstrom at / bei V_{WM} I_D [μA]	Max. clamping voltage Max. Begrenzerspanng. at / bei I_{PPM} (10/1000 μs) V_C [V] I_{PPM} [A]	
	V_{BR} [V]					
P6KE56	56 ± 10%	50.4...61.6	45.4	5	80.5	7.8
P6KE56A	56 ± 5%	53.2...58.8	47.8	5	77.0	8.1
P6KE62	62 ± 10%	55.8...68.8	50.2	5	89.0	7.0
P6KE62A	62 ± 5%	58.9...65.1	53.0	5	85.0	7.4
P6KE68	68 ± 10%	61.2...74.8	55.1	5	98.0	6.4
P6KE68A	68 ± 5%	64.6...71.4	58.1	5	92.0	6.8
P6KE75	75 ± 10%	67.5...82.5	60.7	5	108	5.8
P6KE75A	75 ± 5%	71.3...78.8	64.1	5	103	6.1
P6KE82	82 ± 10%	73.8...90.2	66.4	5	118	5.3
P6KE82A	82 ± 5%	77.9...86.1	70.1	5	113	5.5
P6KE91	91 ± 10%	81.9...100	73.7	5	131	4.8
P6KE91A	91 ± 5%	86.5...95.5	77.8	5	125	5.0
P6KE100	100 ± 10%	90.0...110	81.0	5	144	4.3
P6KE100A	100 ± 5%	95.0...105	85.5	5	137	4.5
P6KE110	110 ± 10%	99.0...121	89.2	5	158	3.9
P6KE110A	110 ± 5%	105...116	94.0	5	152	4.1
P6KE120	120 ± 10%	108...132	97.2	5	173	3.6
P6KE120A	120 ± 5%	114...126	102	5	165	3.8
P6KE130	130 ± 10%	117...143	105	5	187	3.3
P6KE130A	130 ± 5%	124...137	111	5	179	3.5
P6KE150	150 ± 10%	135...165	121	5	215	2.9
P6KE150A	150 ± 5%	143...158	128	5	207	3.0
P6KE160	160 ± 10%	144...176	130	5	230	2.7
P6KE160A	160 ± 5%	152...168	136	5	219	2.8
P6KE170	170 ± 10%	153...187	138	5	244	2.5
P6KE170A	170 ± 5%	162...179	145	5	234	2.6
P6KE180	180 ± 10%	162...198	146	5	258	2.4
P6KE180A	180 ± 5%	171...189	154	5	246	2.5
P6KE200	200 ± 10%	180...220	162	5	287	2.1
P6KE200A	200 ± 5%	190...210	171	5	274	2.2
P6KE220	220 ± 10%	198...242	175	5	344	1.8
P6KE220A	220 ± 5%	209...231	185	5	328	1.9
P6KE250	250 ± 10%	225...275	202	5	360	1.7
P6KE250A	250 ± 5%	237...263	214	5	344	1.8
P6KE300	300 ± 10%	270...330	243	5	430	1.4
P6KE300A	300 ± 5%	285...315	256	5	414	1.5
P6KE350	350 ± 10%	315...385	284	5	504	1.2
P6KE350A	350 ± 5%	332...368	300	5	482	1.3
P6KE400	400 ± 10%	360...440	324	5	574	1.0
P6KE400A	400 ± 5%	380...420	342	5	548	1.1
P6KE440	440 ± 10%	396...484	356	5	631	0.99
P6KE440A	440 ± 5%	418...462	376	5	602	1.04
P6KE520C ¹⁾	520 ± 10%	470...570	423	5	745	0.81

¹⁾ Available only bidirectional version - nur bidirectionale Ausführung lieferbar

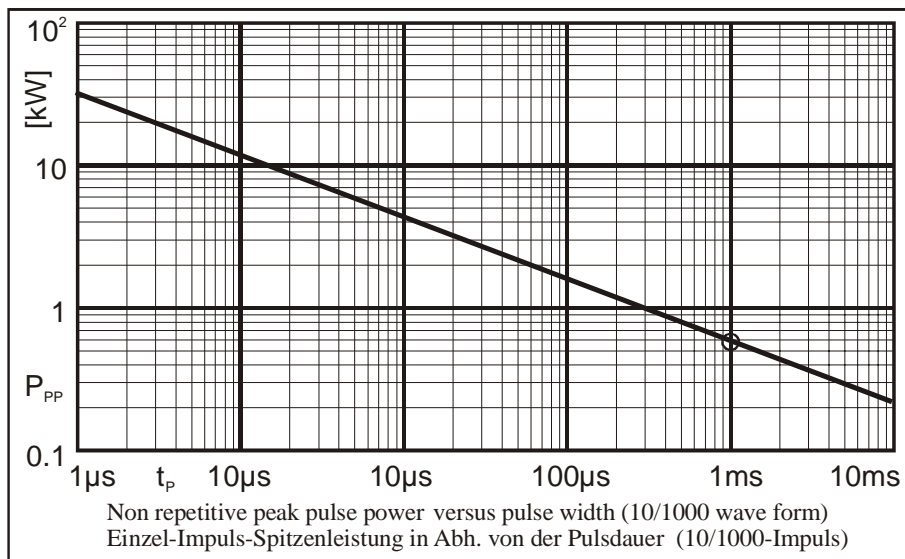
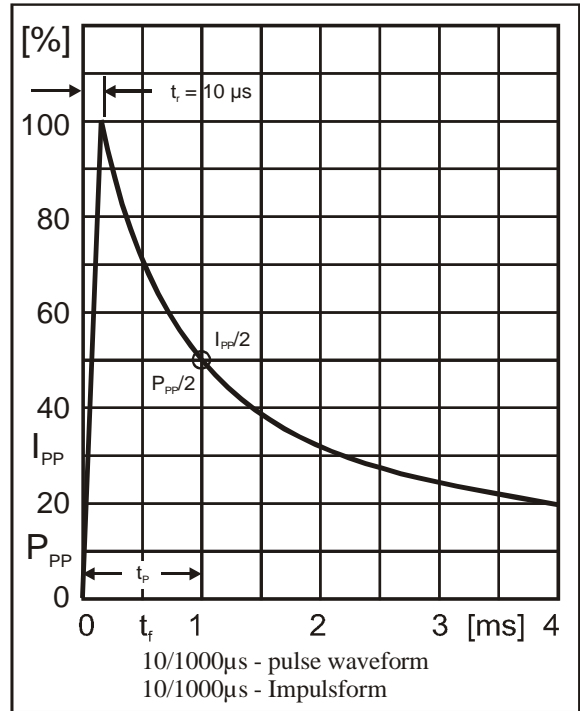
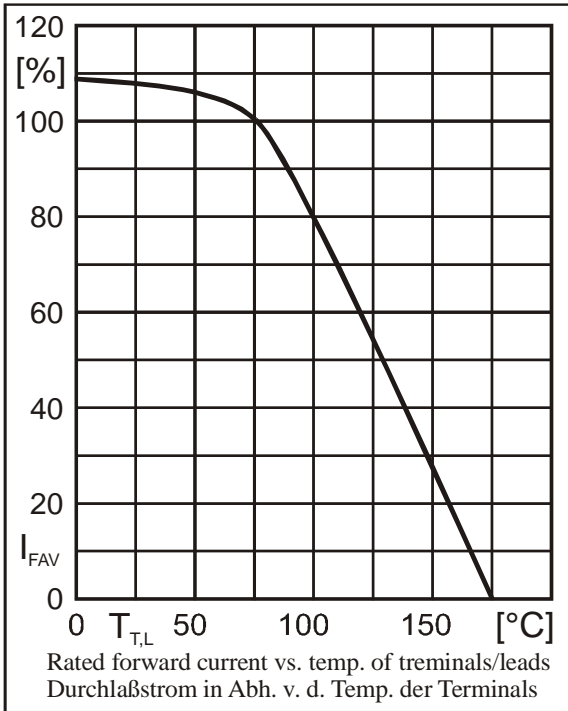

The order of type numbers is graded to the international E 24 standard. The standard tolerance of the breakdown voltage for each type is $\pm 10\%$. Suffix “A” denotes a tolerance of $\pm 5\%$.

Die Abstufung der Typen innerhalb der Reihe entspricht dem internationalen E 24-Standard. Die Toleranz der Arbeitsspannung jedes einzelnen Typs beträgt in der Standardausführung $\pm 10\%$. Suffix “A” kennzeichnet eine Toleranz von $\pm 5\%$.