

**PGA206
PGA207**

High-Speed Programmable Gain INSTRUMENTATION AMPLIFIER

FEATURES

- **DIGITALLY PROGRAMMABLE GAINS:**
PGA206: $G=1, 2, 4, 8V/V$
PGA207: $G=1, 2, 5, 10V/V$
- **TRUE INSTRUMENTATION AMP INPUT**
- **FAST SETTLING: $3.5\mu s$ to 0.01%**
- **FET INPUT: $I_B = 100pA$ max**
- **INPUT PROTECTION: $\pm 40V$**
- **LOW OFFSET VOLTAGE: 1.5mV max**
- **16-PIN DIP, SOL-16 SOIC PACKAGES**

APPLICATIONS

- **MULTIPLE-CHANNEL DATA ACQUISITION**
- **MEDICAL, PHYSIOLOGICAL AMPLIFIER**
- **PC-CONTROLLED ANALOG INPUT BOARDS**

DESCRIPTION

The PGA206 and PGA207 are digitally programmable gain instrumentation amplifiers that are ideally suited for data acquisition systems.

The PGA206 and PGA207's fast settling time allows multiplexed input channels for excellent system efficiency. FET inputs eliminate I_B errors due to analog multiplexer series resistance.

Gains are selected by two CMOS/TTL-compatible address lines. Analog inputs are internally protected for overloads up to $\pm 40V$, even with the power supplies off. The PGA206 and PGA207 are laser-trimmed for low offset voltage and low drift.

The PGA206 and PGA207 are available in 16-pin plastic DIP and SOL-16 surface-mount packages. Both are specified for $-40^\circ C$ to $+85^\circ C$ operation.

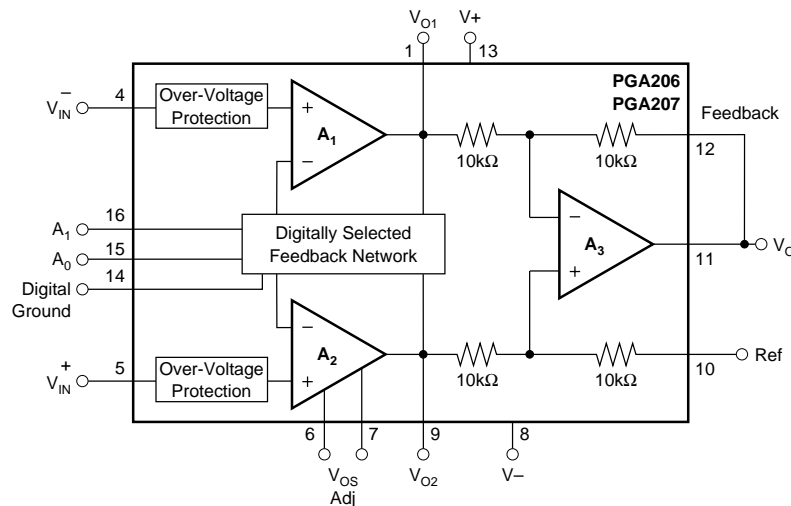

International Airport Industrial Park • Mailing Address: PO Box 11400, Tucson, AZ 85734 • Street Address: 6730 S. Tucson Blvd., Tucson, AZ 85706 • Tel: (520) 746-1111 • Twx: 910-952-1111
Internet: <http://www.burr-brown.com/> • FAXLine: (800) 548-6133 (US/Canada Only) • Cable: BBRCORP • Telex: 066-6491 • FAX: (520) 889-1510 • Immediate Product Info: (800) 548-6132

SPECIFICATIONS

At $T_A = +25^\circ\text{C}$, $V_S = \pm 15\text{V}$, $R_L = 2\text{k}\Omega$ unless otherwise noted.

PARAMETER	CONDITIONS	PGA206P, U PGA207P, U			PGA206PA, UA PGA207PA, UA			UNITS
		MIN	TYP	MAX	MIN	TYP	MAX	
INPUT								
Offset Voltage, RTI	All Gains $T_A = +25^\circ\text{C}$ $T_A = T_{\text{MIN}}$ to T_{MAX} , $G = 8, 10$ $V_S = \pm 4.5\text{V}$ to $\pm 18\text{V}$		± 0.5	± 1.5		± 1	± 2.5	mV
Initial			± 2			*		$\mu\text{V}/^\circ\text{C}$
vs Temperature			± 5	± 20		± 10	± 40	$\mu\text{V}/\text{V}$
vs Power Supply				4.5				$\mu\text{V}/\text{mo}$
Long-Term Stability				$10^{13} \parallel 1$				$\Omega \parallel \text{pF}$
Impedance, Differential			$10^{12} \parallel 4$				$\Omega \parallel \text{pF}$	
Common-Mode							V	
Common-Mode Voltage Range ⁽¹⁾	$V_O = 0\text{V}$	$\pm(V_S - 4)$	$\pm(V_S - 2.5)$		*	*	V	
Safe Input Voltage				± 40			*	V
Common-Mode Rejection	$V_{\text{CM}} = \pm 11\text{V}$, $\Delta R_S = 1\text{k}\Omega$							
	$G = 1$	80	92		75	86		dB
	$G = 2$	85	96		80	90		dB
	$G = 4$ or 5	90	100		84	94		dB
	$G = 8$ or 10	95	100		84	94		dB
INPUT BIAS CURRENT	$V_{\text{IN}} = 0$		2	100		*	*	pA
vs Temperature			See Typical Curve			*		
Offset Current			1	100		*	*	pA
vs Temperature			See Typical Curve			*		
NOISE VOLTAGE, RTI	$G = 8, 10$; $R_S = 0\Omega$							
$f = 10\text{Hz}$			30			*		$\text{nV}/\sqrt{\text{Hz}}$
$f = 100\text{Hz}$			20			*		$\text{nV}/\sqrt{\text{Hz}}$
$f = 1\text{kHz}$			18			*		$\text{nV}/\sqrt{\text{Hz}}$
$f_B = 0.1\text{Hz}$ to 10Hz			1			*		$\mu\text{Vp-p}$
Noise Current								
$f = 1\text{kHz}$			1.5			*		$\text{fA}/\sqrt{\text{Hz}}$
GAIN	All Gains, $V_O = \pm 11\text{V}$							
Gain Error			± 0.01	± 0.05		*	± 0.1	%
Gain vs Temperature ⁽²⁾			± 1	± 10		*	*	$\text{ppm}/^\circ\text{C}$
Nonlinearity			± 0.0003	± 0.002		*	± 0.005	% of FSR
OUTPUT								
Voltage, Positive		(V+) -4	(V+) -2.3		*	*		V
Negative		(V-) +4	(V-) +1.5		*	*		V
Load Capacitance Stability			1000			*		pF
Short-Circuit Current			± 17			*		mA
FREQUENCY RESPONSE								
Bandwidth, -3dB	$G = 1$		5			*		MHz
	$G = 2$		4			*		MHz
	$G = 4, 5$		1.3			*		MHz
	$G = 8, 10$		600			*		kHz
Slew Rate	$V_O = \pm 10\text{V}$, $G = 1$ to 10		25			*		$\text{V}/\mu\text{s}$
Settling Time, 0.1%	20V Step, All Gains		2			*		μs
0.01%	20V Step, All Gains		3.5			*		μs
Output Overload Recovery	50% Overdrive		1.5			*		μs
DIGITAL LOGIC INPUTS								
Digital Ground Voltage, V_{DG}		V-		(V+) -4	*		*	V
Digital Low Voltage		V-		$V_{\text{DG}} + 0.8\text{V}$	*		*	V
Digital Input Current			1			*		pA
Digital High Voltage		$V_{\text{DG}} + 2$		V+	*		*	V
Gain Switching Time			500			*		ns
POWER SUPPLY								
Voltage Range		± 4.5	± 15	± 18	*	*	*	V
Current	$V_{\text{IN}} = 0\text{V}$		$\pm 12.4/-11.2$	± 13.5		*		mA
TEMPERATURE RANGE								
Specification		-40		+85	*		*	$^\circ\text{C}$
Operating		-40		+125	*		*	$^\circ\text{C}$
Thermal Resistance, θ_{JA}			80			*		$^\circ\text{C}/\text{W}$

* Specification same as PGA206P or PGA207P.

NOTES: (1) Input common-mode range varies with output voltage—see typical curves. (2) Guaranteed by wafer test.

The information provided herein is believed to be reliable; however, BURR-BROWN assumes no responsibility for inaccuracies or omissions. BURR-BROWN assumes no responsibility for the use of this information, and all use of such information shall be entirely at the user's own risk. Prices and specifications are subject to change without notice. No patent rights or licenses to any of the circuits described herein are implied or granted to any third party. BURR-BROWN does not authorize or warrant any BURR-BROWN product for use in life support devices and/or systems.

PIN CONFIGURATION

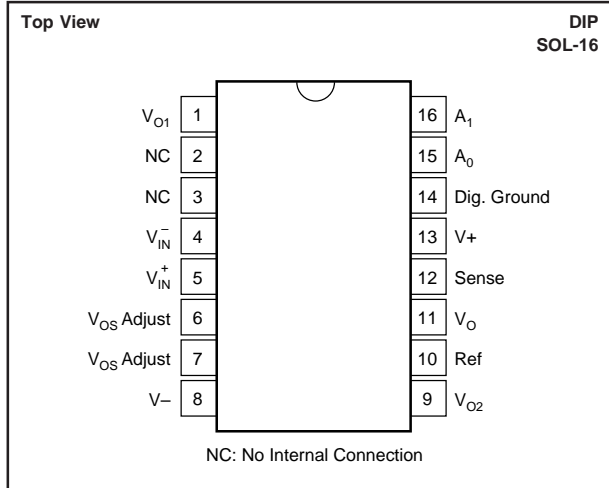

PACKAGE INFORMATION

PRODUCT	PACKAGE	PACKAGE DRAWING NUMBER ⁽¹⁾
PGA206PA	16-Pin Plastic DIP	180
PGA206P	16-Pin Plastic DIP	180
PGA206UA	SOL-16 Surface Mount	211
PGA206U	SOL-16 Surface Mount	211
PGA207PA	16-Pin Plastic DIP	180
PGA207P	16-Pin Plastic DIP	180
PGA207UA	SOL-16 Surface Mount	211
PGA207U	SOL-16 Surface Mount	211

NOTE: (1) For detailed drawing and dimension table, please see end of data sheet, or Appendix C of Burr-Brown IC Data Book.

ABSOLUTE MAXIMUM RATINGS

Supply Voltage	$\pm 18V$
Analog Input Voltage Range	$\pm 40V$
Logic Input Voltage Range	$\pm V_S$
Output Short-Circuit (to ground)	Continuous
Operating Temperature	$-40^\circ C$ to $+125^\circ C$
Storage Temperature	$-40^\circ C$ to $+125^\circ C$
Junction Temperature	$+150^\circ C$
Lead Temperature (soldering -10s)	$+300^\circ C$

ORDERING INFORMATION

PRODUCT	GAINS	PACKAGE	TEMPERATURE RANGE
PGA206PA	1, 2, 4, 8V/V	16-Pin Plastic DIP	$-40^\circ C$ to $+85^\circ C$
PGA206P	1, 2, 4, 8V/V	16-Pin Plastic DIP	$-40^\circ C$ to $+85^\circ C$
PGA206UA	1, 2, 4, 8V/V	SOL-16 Surface-Mount	$-40^\circ C$ to $+85^\circ C$
PGA206U	1, 2, 4, 8V/V	SOL-16 Surface-Mount	$-40^\circ C$ to $+85^\circ C$
PGA207PA	1, 2, 5, 10V/V	16-Pin Plastic DIP	$-40^\circ C$ to $+85^\circ C$
PGA207P	1, 2, 5, 10V/V	16-Pin Plastic DIP	$-40^\circ C$ to $+85^\circ C$
PGA207UA	1, 2, 5, 10V/V	SOL-16 Surface-Mount	$-40^\circ C$ to $+85^\circ C$
PGA207U	1, 2, 5, 10V/V	SOL-16 Surface-Mount	$-40^\circ C$ to $+85^\circ C$



ELECTROSTATIC DISCHARGE SENSITIVITY

This integrated circuit can be damaged by ESD. Burr-Brown recommends that all integrated circuits be handled with appropriate precautions. Failure to observe proper handling and installation procedures can cause damage.

ESD damage can range from subtle performance degradation to complete device failure. Precision integrated circuits may be more susceptible to damage because very small parametric changes could cause the device not to meet its published specifications.

TYPICAL PERFORMANCE CURVES

At $T_A = +25^\circ\text{C}$, and $V_S = \pm 15\text{V}$, unless otherwise noted.

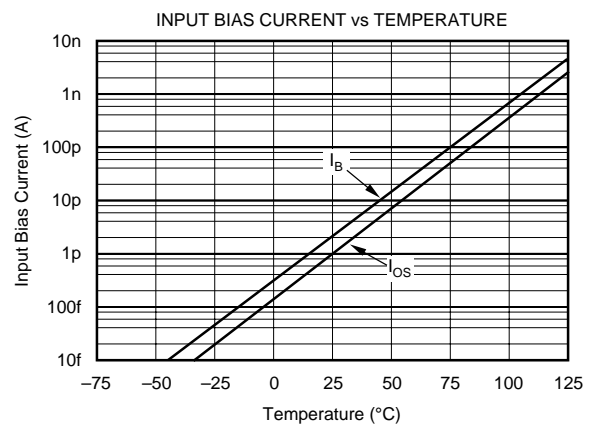
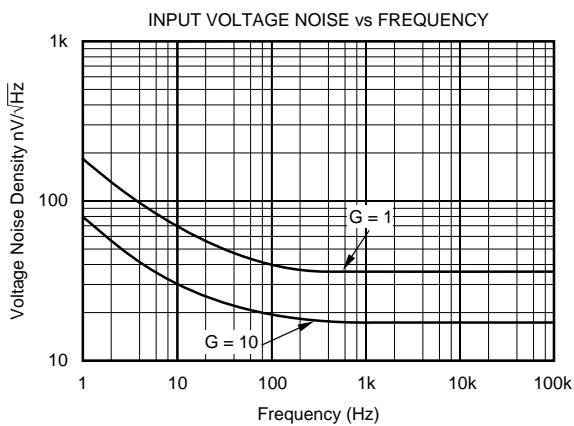
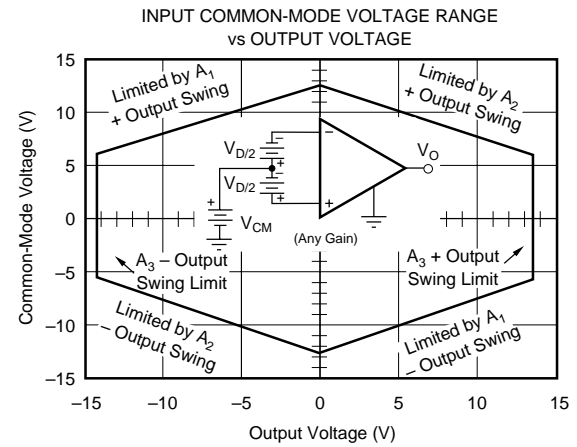
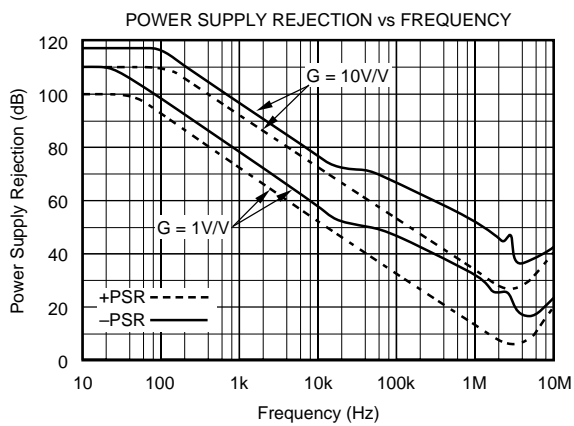
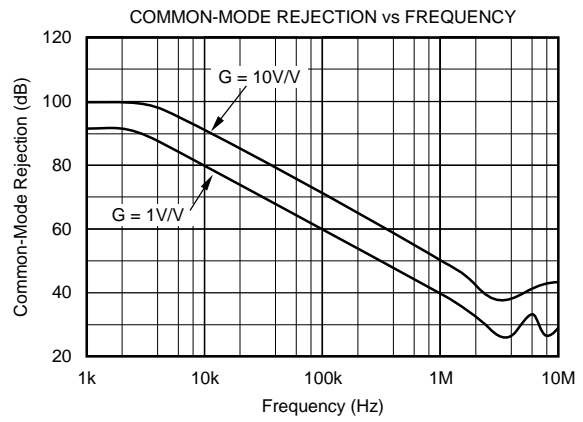
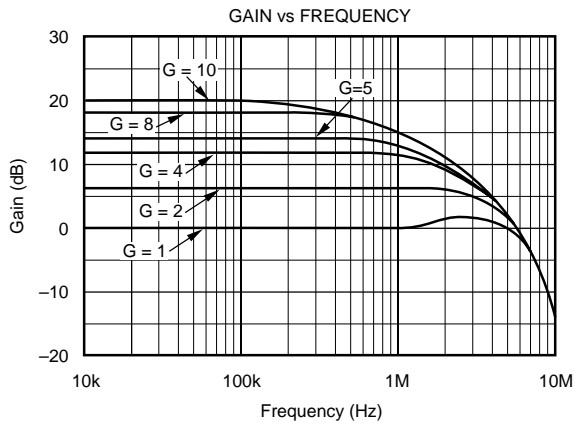

TYPICAL PERFORMANCE CURVES (CONT)

At $T_A = +25^\circ\text{C}$, and $V_S = \pm 15\text{V}$, unless otherwise noted.

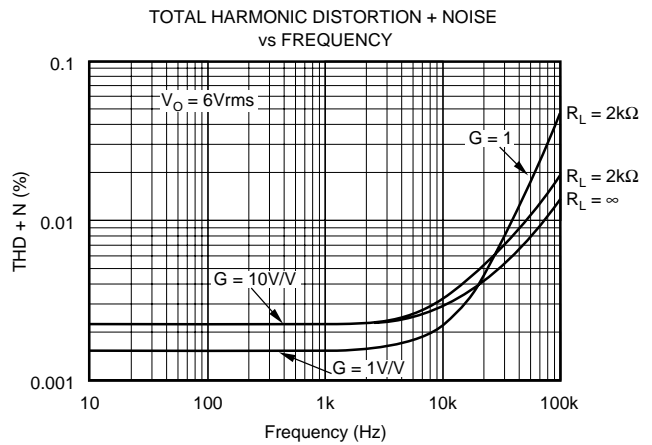
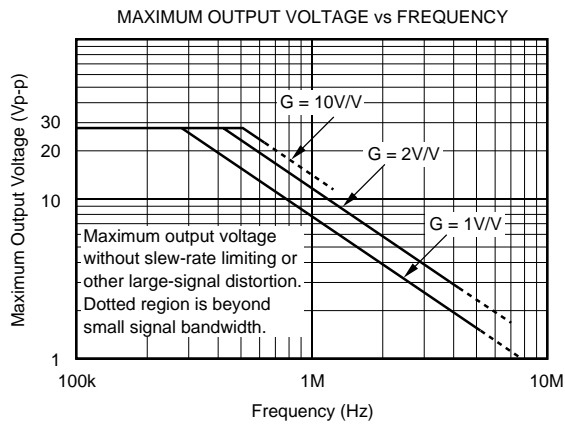
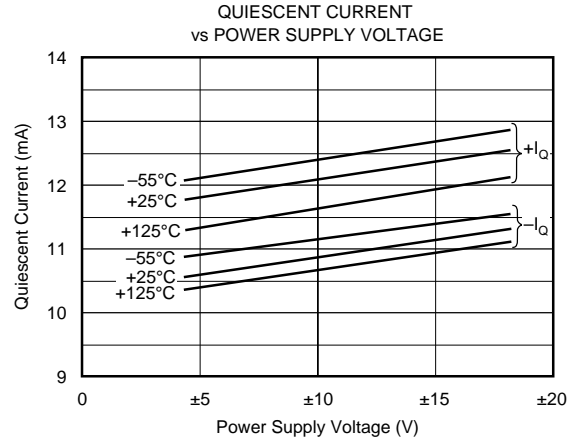
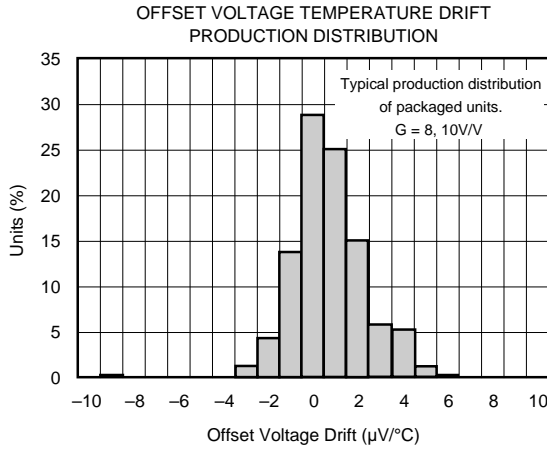
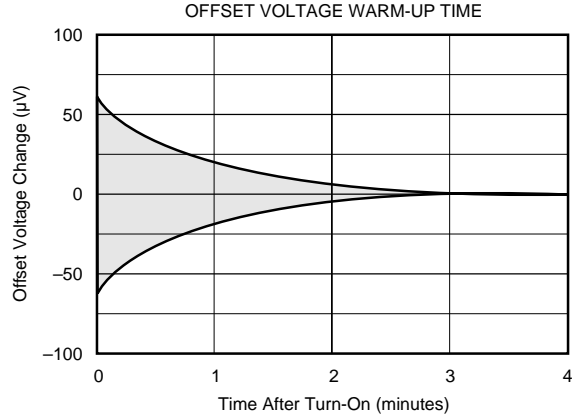
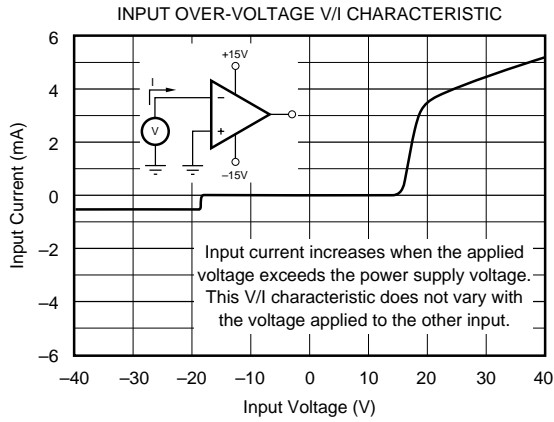

TYPICAL PERFORMANCE CURVES (CONT)

At $T_A = +25^\circ\text{C}$, and $V_S = \pm 15\text{V}$, unless otherwise noted.

SMALL SIGNAL RESPONSE
 $G = 1, C_L = 50\text{pF}$

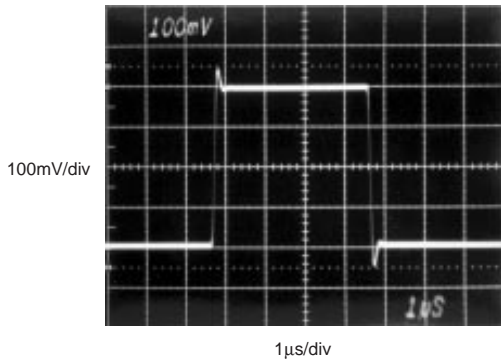

SMALL SIGNAL RESPONSE
 $G = 10, C_L = 50\text{pF}$

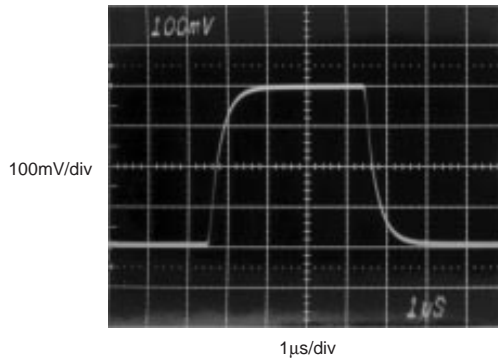

LARGE SIGNAL RESPONSE
 $G = 1, C_L = 50\text{pF}$

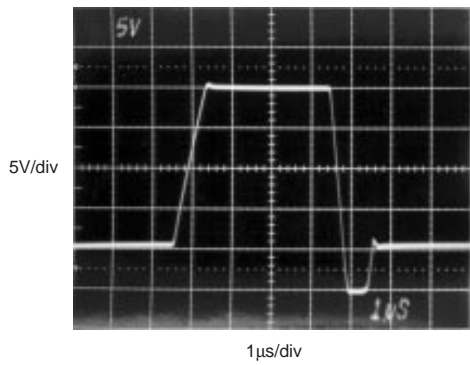

LARGE SIGNAL RESPONSE
 $G = 10, C_L = 50\text{pF}$

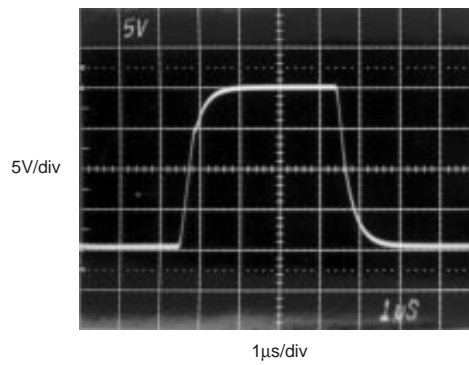

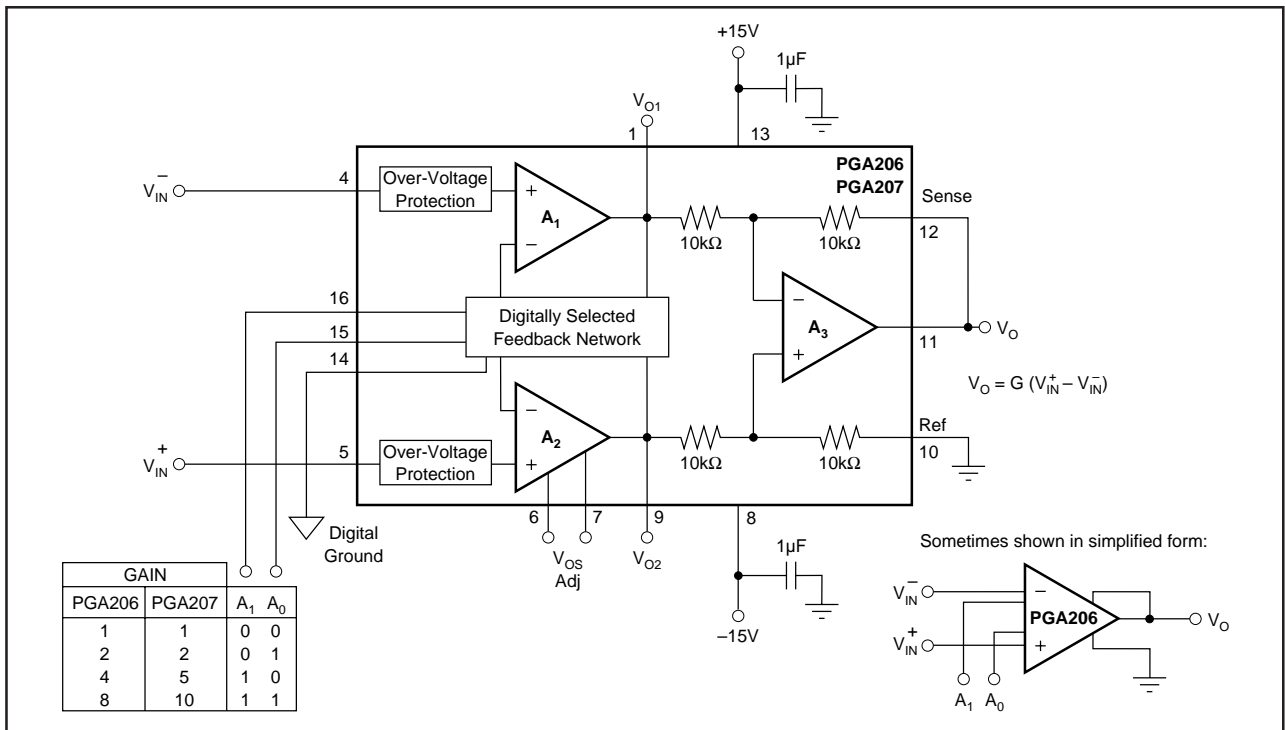

FIGURE 1. Basic Connections.

APPLICATIONS INFORMATION

Figure 1 shows the circuit diagram for basic operation of the PGA206 or PGA207. Applications with noisy or high impedance power supplies may require decoupling capacitors close to the device pins as shown.

The output is referred to the output reference (Ref) terminal which is normally grounded. This must be a low-impedance connection to assure good common-mode rejection. A resistance of 2Ω in series with the Ref pin will cause a typical device to degrade to approximately 80dB CMR ($G = 1$).

The output sense connection (pin 12) must be connected to the output terminal (pin 11) for proper operation. This connection can be made at the load for best accuracy.

DIGITAL INPUTS

The digital inputs A_0 and A_1 select the gain according to the logic table in Figure 1. Logic “1” is defined as a voltage greater than 2V above digital ground potential (pin 14). Digital ground can be connected to any potential ranging from the V^- power supply to 4V less than V^+ . Digital ground is usually equal to analog ground potential and the two grounds are connected at the power supply. The digital inputs interface directly to CMOS and TTL logic.

A nearly constant current of approximately 1.2mA flows in the digital ground pin. It is good practice to return digital ground through a separate connection path so that analog ground is not affected by the digital ground current.

The digital inputs, A_0 and A_1 , are not latched. A change in logic input immediately selects a new gain. Switching time of the logic is approximately 500ns. The time to respond to gain change is equal to switching time, plus the time it takes the amplifier to settle to a new output voltage in the newly selected gain (see settling time specifications).

Many applications use an external logic latch to acquire gain control data from a high speed digital bus. Using an external latch isolates the high speed digital bus from sensitive analog circuitry. Locate the digital latch as far as practical from analog circuitry to avoid coupling digital noise into analog input circuitry.

OFFSET VOLTAGE ADJUSTMENT

The PGA206 and PGA207 are laser trimmed for very low offset voltage and drift. Many applications require no external offset adjustment. Multiplexed data acquisition systems generally correct offset by grounding the inputs of one channel to measure offset voltage. Stored offset values for each gain are then subtracted from subsequent readings of other channels.

Figure 2 shows optional offset voltage trim circuits. Offset voltage changes with the selected gain. To adjust for low offset voltage in all gains, both input and output offsets must be trimmed.

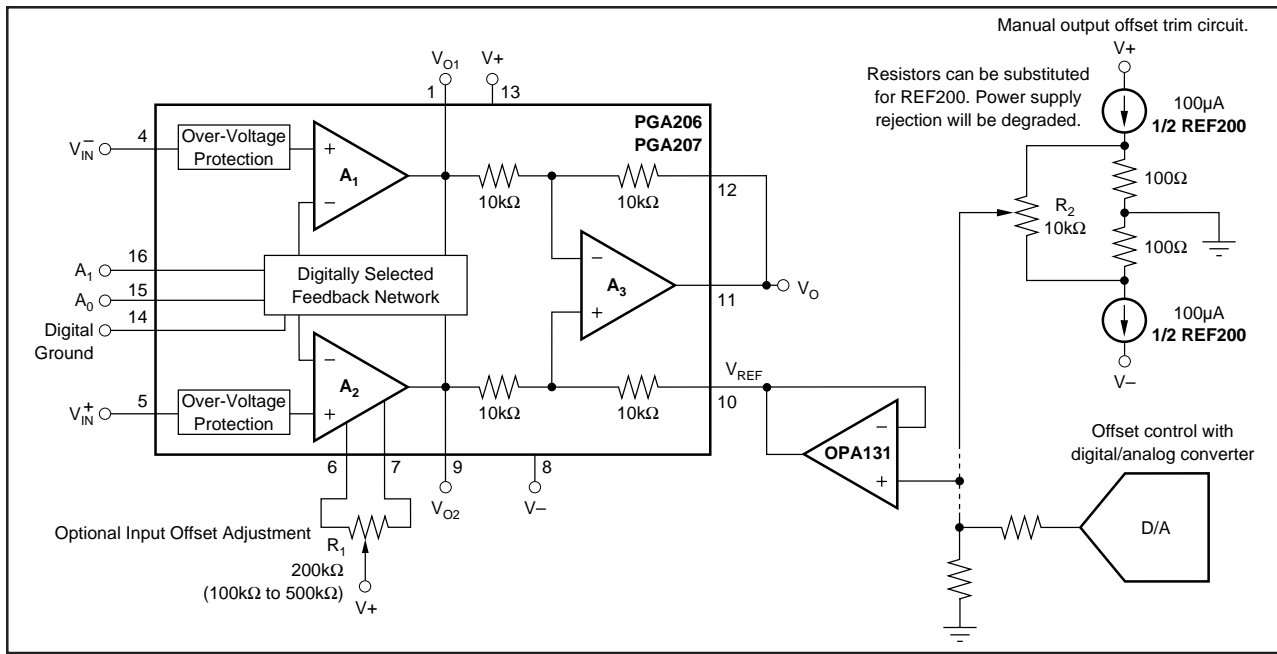

FIGURE 2. Optional Offset Voltage Trim Circuits.

R_1 adjusts the offset of the input amplifiers. Output stage offset is adjusted with R_2 . A buffer op amp is required in the output offset adjustment circuit, as shown, to assure that the Ref pin is driven by a low source impedance. To adjust for low offset voltage in all gains, first adjust the input stage offset in the highest gain. Then adjust the output stage offset (R_2) in $G = 1$. Iterate the adjustments for lowest offset in all gains.

Offset can also be adjusted under processor control with a D/A converter as shown in Figure 2. The D/A's output voltage can be reduced with a resistor divider for better adjustment resolution, but an op amp buffer following the divider is required to provide a low source impedance to the ref terminal. A different offset value is required for each amplifier gain.

INPUT BIAS CURRENT RETURN PATH

The FET inputs of the PGA206 and PGA207 provide extremely high input impedance. Still, a path must be provided for the bias current of each input. Figure 3 shows provisions for an input bias current path. Without a bias current return path, the inputs will float to a potential which exceeds the linear input voltage range and the input amplifiers will saturate.

If the differential source resistance is low, a bias current return path can be connected to only one input (see thermocouple example in Figure 3). With higher source impedance, using two resistors provides a balanced input with possible advantages of lower input offset voltage due to bias current and better common-mode rejection.

Many sources or sensors inherently provide a path for input bias current (e.g. the bridge sensor shown in Figure 3). These applications do not require additional resistor(s) for proper operation.

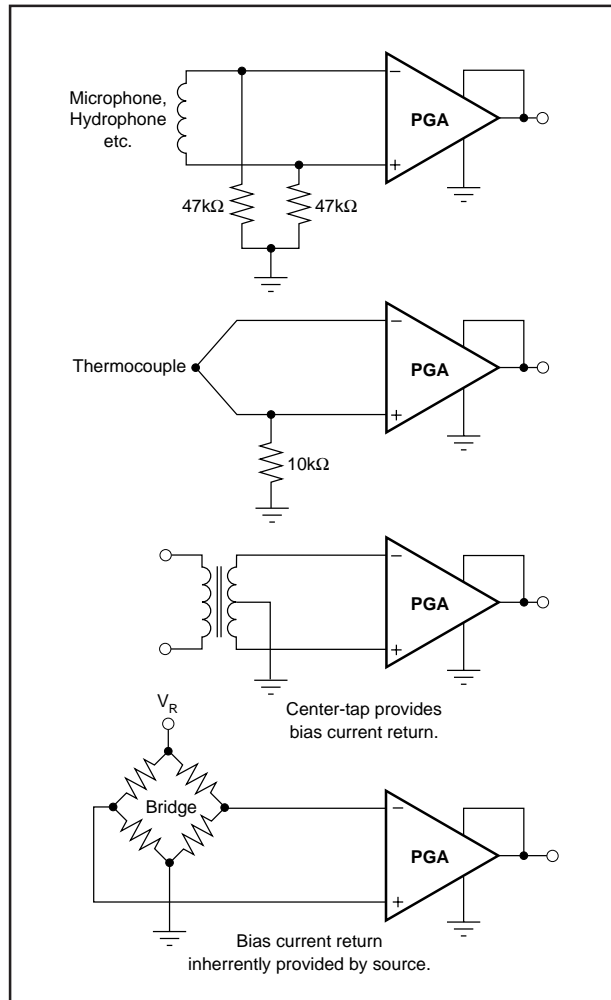

FIGURE 3. Providing an Input Bias Current Path.

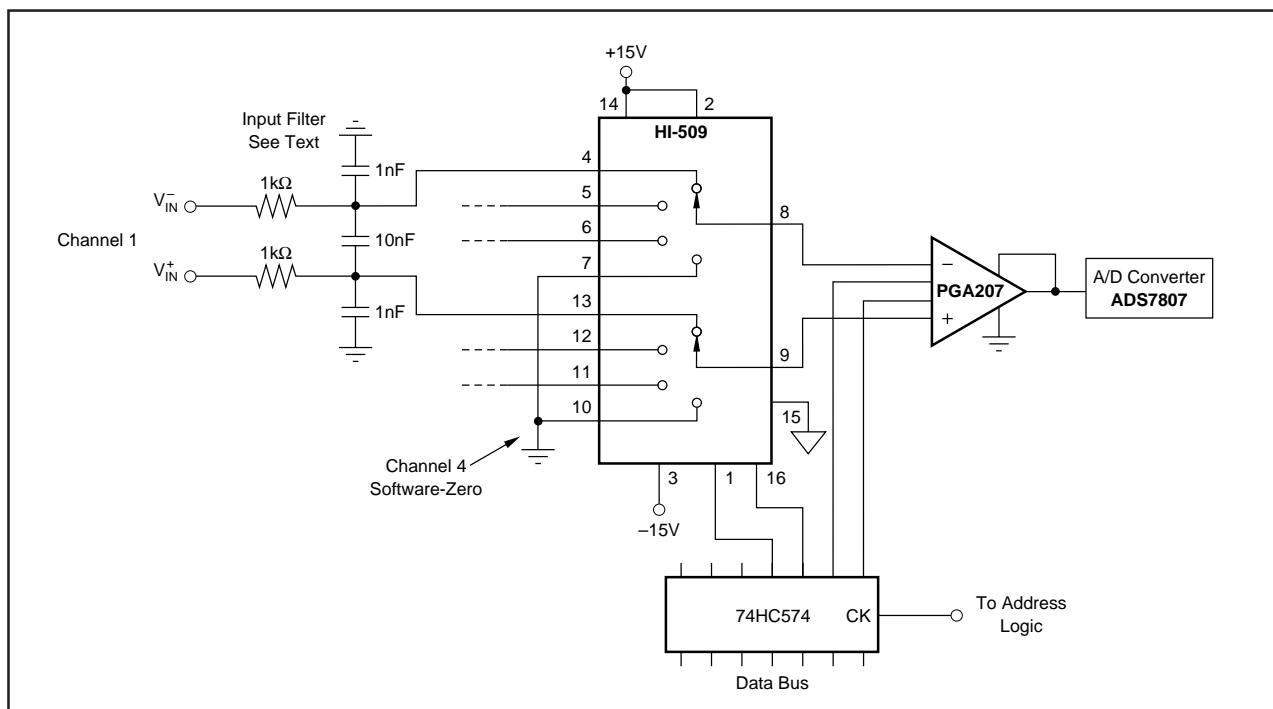

FIGURE 4. Multiplexed-Input Signal Acquisition System.

INPUT COMMON-MODE RANGE

The linear input voltage range of the PGA206 and PGA207 is from approximately 2.3V below the positive supply voltage to 1.5V above the negative supply. As a differential input voltage causes output voltage to increase, however, the linear input range is limited by the output voltage swing of amplifiers A_1 and A_2 . So the linear common-mode input range is related to the output voltage of the complete amplifier. This behavior also depends on supply voltage—see performance curves “Input Common-Mode Range vs Output Voltage”.

Input overload can produce an output voltage that appears normal. For example, if an input overload condition drives both input amplifiers to their positive output swing limit, the difference voltage measured by the output amplifier will be near zero. The output of the PGA206 or PGA207 will be near 0V even though both inputs are overloaded. This condition can be detected by sensing the voltage on the V_{O1} and V_{O2} pins to determine whether they are within their linear operating range.

INPUT PROTECTION

The inputs of the PGA206 and PGA207 are individually protected for voltages up to $\pm 40V$. For example, a condition of $-40V$ on one input and $+40V$ on the other input will not cause damage. Internal circuitry on each input provides low series impedance under normal signal conditions. If the input is overloaded, the protection circuitry limits the input current to a safe value. The typical performance curve “Input Overload V/I Characteristic” shows this behavior. The inputs are protected even if no power supply voltage is applied.

MULTIPLEXED INPUTS

The PGA206 and PGA207 are ideally suited for multiple channel data acquisition. Figure 4 shows a typical application with an analog multiplexer used to connect one of four differential input signals to a single PGA207.

Careful circuit layout will help preserve accuracy of multiplexed signals. Run the inverting and non-inverting connections of each channel parallel to each other over a ground plane, or directly adjacent on top and bottom of the circuit board. Grounded guard traces between channels help reduce stray signal pick-up.

Multiplexed signals from high impedance sources require special care. As inputs are switched by the multiplexer, charge can be injected into the source, disturbing the input signal. Since many such sources involve slow signals, a simple R/C filter at the input can be used to dramatically reduce this effect. The arrangement shown filters both the differential signal and common-mode noise.

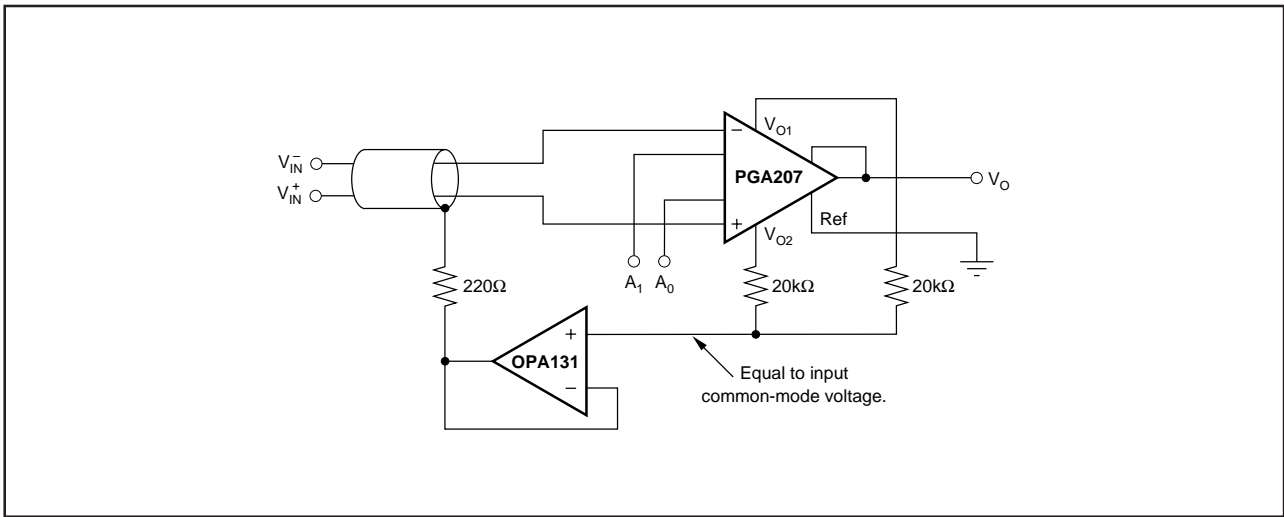

FIGURE 5. Shield Drive Circuit.

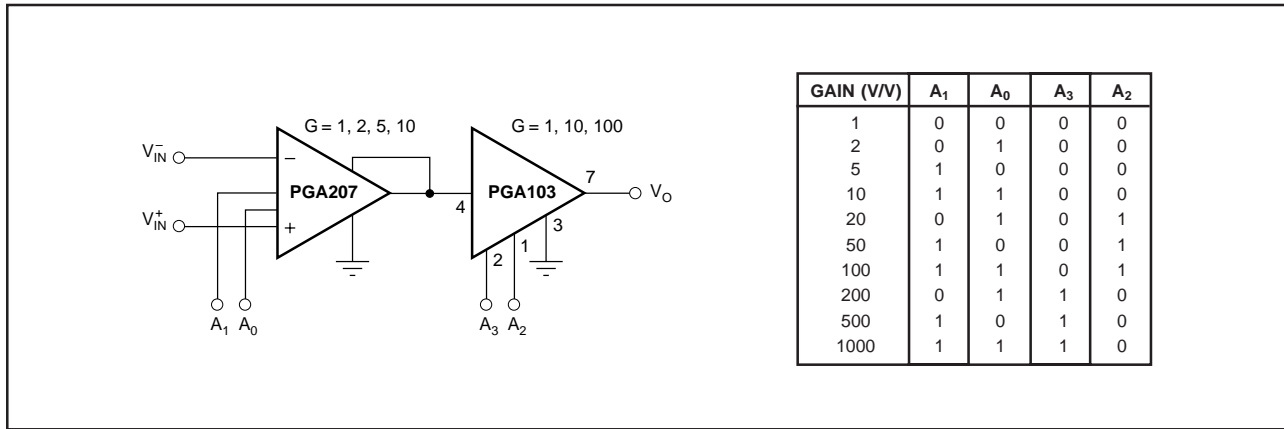

FIGURE 6. Wide Gain Range Programmable IA.

PACKAGING INFORMATION

Orderable Device	Status ⁽¹⁾	Package Type	Package Drawing	Pins	Package Qty	Eco Plan ⁽²⁾	Lead/Ball Finish	MSL Peak Temp ⁽³⁾
PGA206PA	ACTIVE	PDIP	N	16	25	Green (RoHS & no Sb/Br)	CU NIPDAU	N / A for Pkg Type
PGA206PAG4	ACTIVE	PDIP	N	16	25	Green (RoHS & no Sb/Br)	CU NIPDAU	N / A for Pkg Type
PGA206UA	ACTIVE	SOIC	DW	16	40	Green (RoHS & no Sb/Br)	CU NIPDAU	Level-3-260C-168 HR
PGA206UAG4	ACTIVE	SOIC	DW	16	40	Green (RoHS & no Sb/Br)	CU NIPDAU	Level-3-260C-168 HR
PGA207PA	OBSOLETE	PDIP	N	16		TBD	Call TI	Call TI
PGA207UA	ACTIVE	SOIC	DW	16	40	Green (RoHS & no Sb/Br)	CU NIPDAU	Level-3-260C-168 HR
PGA207UA/1K	ACTIVE	SOIC	DW	16	1000	Green (RoHS & no Sb/Br)	CU NIPDAU	Level-3-260C-168 HR
PGA207UA/1KE4	ACTIVE	SOIC	DW	16	1000	Green (RoHS & no Sb/Br)	CU NIPDAU	Level-3-260C-168 HR
PGA207UAE4	ACTIVE	SOIC	DW	16	40	Green (RoHS & no Sb/Br)	CU NIPDAU	Level-3-260C-168 HR

⁽¹⁾ The marketing status values are defined as follows:

ACTIVE: Product device recommended for new designs.

LIFEBUY: TI has announced that the device will be discontinued, and a lifetime-buy period is in effect.

NRND: Not recommended for new designs. Device is in production to support existing customers, but TI does not recommend using this part in a new design.

PREVIEW: Device has been announced but is not in production. Samples may or may not be available.

OBSOLETE: TI has discontinued the production of the device.

⁽²⁾ Eco Plan - The planned eco-friendly classification: Pb-Free (RoHS), Pb-Free (RoHS Exempt), or Green (RoHS & no Sb/Br) - please check <http://www.ti.com/productcontent> for the latest availability information and additional product content details.

TBD: The Pb-Free/Green conversion plan has not been defined.

Pb-Free (RoHS): TI's terms "Lead-Free" or "Pb-Free" mean semiconductor products that are compatible with the current RoHS requirements for all 6 substances, including the requirement that lead not exceed 0.1% by weight in homogeneous materials. Where designed to be soldered at high temperatures, TI Pb-Free products are suitable for use in specified lead-free processes.

Pb-Free (RoHS Exempt): This component has a RoHS exemption for either 1) lead-based flip-chip solder bumps used between the die and package, or 2) lead-based die adhesive used between the die and leadframe. The component is otherwise considered Pb-Free (RoHS compatible) as defined above.

Green (RoHS & no Sb/Br): TI defines "Green" to mean Pb-Free (RoHS compatible), and free of Bromine (Br) and Antimony (Sb) based flame retardants (Br or Sb do not exceed 0.1% by weight in homogeneous material)

⁽³⁾ MSL, Peak Temp. -- The Moisture Sensitivity Level rating according to the JEDEC industry standard classifications, and peak solder temperature.

Important Information and Disclaimer:The information provided on this page represents TI's knowledge and belief as of the date that it is provided. TI bases its knowledge and belief on information provided by third parties, and makes no representation or warranty as to the accuracy of such information. Efforts are underway to better integrate information from third parties. TI has taken and continues to take reasonable steps to provide representative and accurate information but may not have conducted destructive testing or chemical analysis on incoming materials and chemicals. TI and TI suppliers consider certain information to be proprietary, and thus CAS numbers and other limited information may not be available for release.

In no event shall TI's liability arising out of such information exceed the total purchase price of the TI part(s) at issue in this document sold by TI to Customer on an annual basis.

TAPE AND REEL INFORMATION



QUADRANT ASSIGNMENTS FOR PIN 1 ORIENTATION IN TAPE



*All dimensions are nominal

Device	Package Type	Package Drawing	Pins	SPQ	Reel Diameter (mm)	Reel Width W1 (mm)	A0 (mm)	B0 (mm)	K0 (mm)	P1 (mm)	W (mm)	Pin1 Quadrant
PGA207UA/1K	SOIC	DW	16	1000	330.0	16.4	10.85	10.8	2.7	12.0	16.0	Q1

TAPE AND REEL BOX DIMENSIONS



*All dimensions are nominal

Device	Package Type	Package Drawing	Pins	SPQ	Length (mm)	Width (mm)	Height (mm)
PGA207UA/1K	SOIC	DW	16	1000	346.0	346.0	33.0

IMPORTANT NOTICE

Texas Instruments Incorporated and its subsidiaries (TI) reserve the right to make corrections, modifications, enhancements, improvements, and other changes to its products and services at any time and to discontinue any product or service without notice. Customers should obtain the latest relevant information before placing orders and should verify that such information is current and complete. All products are sold subject to TI's terms and conditions of sale supplied at the time of order acknowledgment.

TI warrants performance of its hardware products to the specifications applicable at the time of sale in accordance with TI's standard warranty. Testing and other quality control techniques are used to the extent TI deems necessary to support this warranty. Except where mandated by government requirements, testing of all parameters of each product is not necessarily performed.

TI assumes no liability for applications assistance or customer product design. Customers are responsible for their products and applications using TI components. To minimize the risks associated with customer products and applications, customers should provide adequate design and operating safeguards.

TI does not warrant or represent that any license, either express or implied, is granted under any TI patent right, copyright, mask work right, or other TI intellectual property right relating to any combination, machine, or process in which TI products or services are used. Information published by TI regarding third-party products or services does not constitute a license from TI to use such products or services or a warranty or endorsement thereof. Use of such information may require a license from a third party under the patents or other intellectual property of the third party, or a license from TI under the patents or other intellectual property of TI.

Reproduction of TI information in TI data books or data sheets is permissible only if reproduction is without alteration and is accompanied by all associated warranties, conditions, limitations, and notices. Reproduction of this information with alteration is an unfair and deceptive business practice. TI is not responsible or liable for such altered documentation. Information of third parties may be subject to additional restrictions.

Resale of TI products or services with statements different from or beyond the parameters stated by TI for that product or service voids all express and any implied warranties for the associated TI product or service and is an unfair and deceptive business practice. TI is not responsible or liable for any such statements.

TI products are not authorized for use in safety-critical applications (such as life support) where a failure of the TI product would reasonably be expected to cause severe personal injury or death, unless officers of the parties have executed an agreement specifically governing such use. Buyers represent that they have all necessary expertise in the safety and regulatory ramifications of their applications, and acknowledge and agree that they are solely responsible for all legal, regulatory and safety-related requirements concerning their products and any use of TI products in such safety-critical applications, notwithstanding any applications-related information or support that may be provided by TI. Further, Buyers must fully indemnify TI and its representatives against any damages arising out of the use of TI products in such safety-critical applications.

TI products are neither designed nor intended for use in military/aerospace applications or environments unless the TI products are specifically designated by TI as military-grade or "enhanced plastic." Only products designated by TI as military-grade meet military specifications. Buyers acknowledge and agree that any such use of TI products which TI has not designated as military-grade is solely at the Buyer's risk, and that they are solely responsible for compliance with all legal and regulatory requirements in connection with such use.

TI products are neither designed nor intended for use in automotive applications or environments unless the specific TI products are designated by TI as compliant with ISO/TS 16949 requirements. Buyers acknowledge and agree that, if they use any non-designated products in automotive applications, TI will not be responsible for any failure to meet such requirements.

Following are URLs where you can obtain information on other Texas Instruments products and application solutions:

Products

Amplifiers	amplifier.ti.com
Data Converters	dataconverter.ti.com
DLP® Products	www.dlp.com
DSP	dsp.ti.com
Clocks and Timers	www.ti.com/clocks
Interface	interface.ti.com
Logic	logic.ti.com
Power Mgmt	power.ti.com
Microcontrollers	microcontroller.ti.com
RFID	www.ti-rfid.com
RF/IF and ZigBee® Solutions	www.ti.com/lprf

Applications

Audio	www.ti.com/audio
Automotive	www.ti.com/automotive
Broadband	www.ti.com/broadband
Digital Control	www.ti.com/digitalcontrol
Medical	www.ti.com/medical
Military	www.ti.com/military
Optical Networking	www.ti.com/opticalnetwork
Security	www.ti.com/security
Telephony	www.ti.com/telephony
Video & Imaging	www.ti.com/video
Wireless	www.ti.com/wireless

Mailing Address: Texas Instruments, Post Office Box 655303, Dallas, Texas 75265
Copyright © 2009, Texas Instruments Incorporated