

PIC-MT (Rev. A) DEVELOPMENT BOARD FOR 28 PIN PIC MICROCONTROLLERS

Features:

PIC-MT (mini terminal) is development board for 28 pin PIC microcontrollers with following features:

- ICSP 6 pin connector
- LCD 16x1 alphanumeric display
- 6 buttons
- Dallas iButton interface
- Frequency input
- ADC input
- RS232 interface and connector
- RS232 TTL level interface and connector
- status LED
- relay with 5A/250VAC contacts
- screw terminal blocks on relay contacts
- Audio buzzer
- 4MHz quartz oscillator
- DIL28 microcontroller socket
- +5V power supply voltage regulator
- power supply plug in connector
- dimensions: 120x36 mm
- four mounting holes

Programming:

To program PIC-MT you need serial port or parallel port PIC programmers with ICSP connector (PIC-PG1, PIC-PG3B) or PIC-ICD1-B.

The serial port ICSP programmer (PIC-PG1) works with IC PROG ICPROG software, written by Bonny Gijzen. The latest release of ICPROG may be download for free from <http://www.icprog.com>

The parallel port ICSP programmer (PIC-PG3B) works with Bojan Dobaj's shareware software from <http://www.picallw.com> or Nigel Goodwin's free software from www.lpilsley.uklinux.net

ICD/ICSP connector layout:

The ICD/ICSP connector is 6 pin with 0,1" step. The PIN.1 is marked with square pad on bottom and arrow on top. ICSP signals are: 1- MCLR, 2- VDD, 3- VSS/GND, 4- PGD/RB7, 5- PGC/RB6, 6- PGM/RB3.

PIC-ICSP/ICD

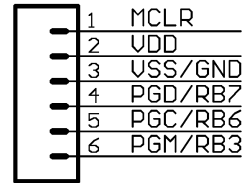

RS232 interface connection:

Rx – RC7, Tx – RC6

LCD connection:

LCD is connected for 4-bit interface

RS - LCD register select RA2

R/W – LCD read write select RA3

E - LCD enable RA5

D4 – RC0

D5 – RC1

D6 – RC2

D7 – RC3

Sample demo program how to drive the LCD is available on Olimex's site.

RS232 interface connection:

Microcontroller connection: Rx – RC7, Tx – RC6

TTL connector: PIN.1 (square) –Tx, PIN.2 –Rx, PIN.3 – GND, PIN.4 – VCC.

RS232 connector: PIN.2 – Tx, PIN.3 – Rx, PIN.5 – GND.

Dallas iButton interface:

Connected to PB5 via protection circuit.

Dallas connector: PIN.1 (square) – Dallas input, PIN.2 – GND.

Buttons connection:

The Button interface uses three microcontroller ports RB0, RB1, RB2. The ports are connected with pull down resistors and are read as "0". To scan the buttons user should set one of the ports in "1" and to check the other two ports.

For example: set port RB0 as output RB1, RB2 as inputs and make RB0= 1. If buttons B1 is pressed RB1 will be "1" too, if button B6 is pressed RB2 will be "1" too. The same way you can scan all other buttons.

Audio buzzer interface:

Connected to RC4 and RC5. User must apply frequency to these microcontroller pin to sound.
RC4=0, RC5=1, delay, RC4=1, RC5=0, delay

Relay output:

Connected to RA1.

Status LED:

Connected to RB4. LED is ON when RB4=0.

ADC input:

Connected to RA0. Input voltage may be 0-5V between PIN.2 and PIN.3 (GND) or 0-10V between PIN.1 and PIN.3.

Frequency input:

Connected to RA4 (TOCKI).

Supported devices:

All PIC 28 pin microcontrollers.

Power supply:

The power supply should be in range +10 +14VDC.

Ordering codes:

PIC-MT - assembled and tested

Board component locations:

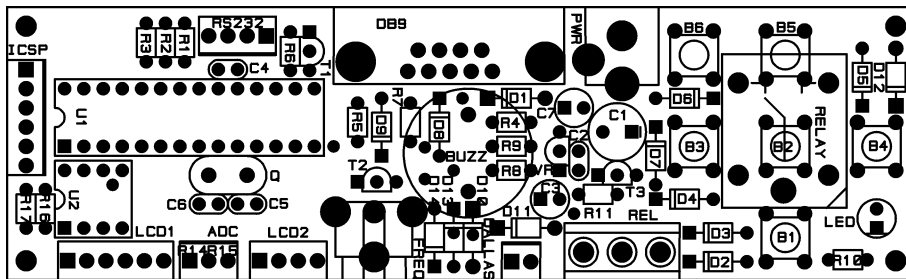

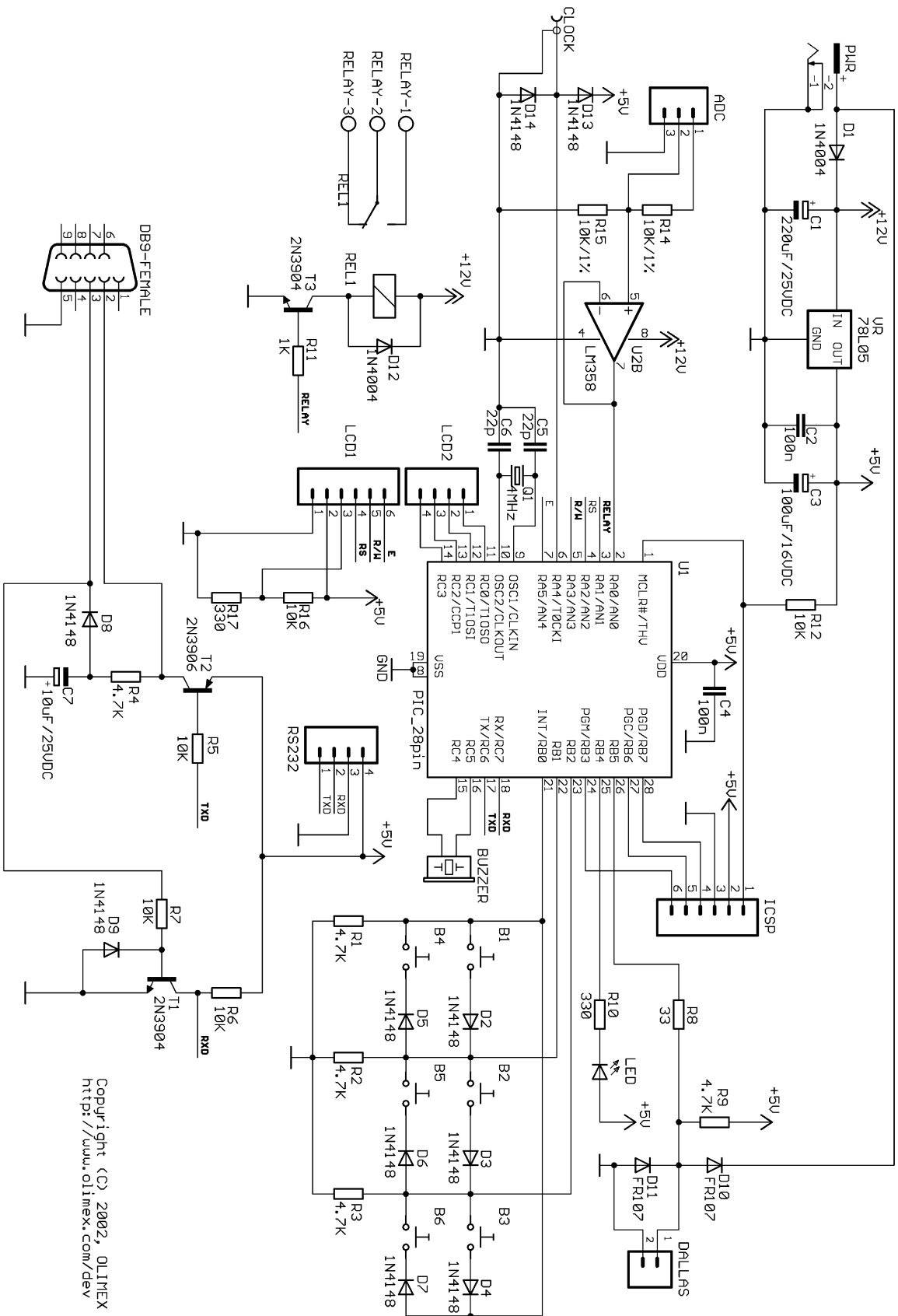

Copyright (C) 2002, OLIMEX Ltd
<http://www.olimex.com/dev>