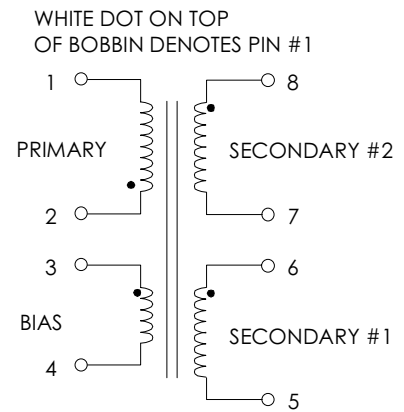

TABLE 1: ELECTRICAL SPECIFICATIONS AT 25 °C
 SWITCHING TRANSFORMER DESIGNED FOR USE WITH POWER INTEGRATIONS
 PWR-TOP202YAI. REFER TO APPLICATION CIRCUIT OF FIGURE 3.

| PARAMETER | SPEC LIMITS | | | UNITS |
|--|---|---|---|--|
| | MIN. | TYP. | MAX. | |
| PRIMARY INDUCTANCE (2-1) VOLTAGE = 0.250Vrms FREQUENCY = 100 KHZ | 675 | 750 | 825 | μHY |
| TURN RATIO'S: SECONDARY'S : PRIMARY (2-1) BIAS (3-4) : PRIMARY (2-1) | ----- | 1:7.714 | ----- | ± 3% |
| PRI LEAKAGE IND. (SEC'S SHORT) VOLTAGE = 0.250Vrms FREQUENCY = 100 KHZ | ----- | 32 | 45 | μHY |
| HIPOT: PRIMARY TO SECONDARY'S BIAS TO SECONDARY'S | 3000 3000 | ----- ----- | ----- ----- | Vrms Vrms |
| APP CIRCUIT PARAMETERS: (1) AC LINE VOLTAGE 47/400 Hz SEC #1 OUTPUT VOLTAGE (2) SEC #1 OUTPUT mA CONTINUOUS SEC #1 LOAD REGULATION 10-100% SEC #2 OUTPUT VOLTAGE SEC #2 OUTPUT mA CONTINUOUS SEC #2 LOAD REGULATION 10-100% LINE REGULATION (85 TO 265Vac) RIPPLE EACH OUTPUT TRANSFORMER TEMPERATURE RISE | 85 ----- 0.0 ----- 0.0 ----- ----- ----- ----- ----- | ----- 12.0 500 0.20 12.0 300 4.00 0.20 50.0 20.0 | 265 ----- 520 ----- 320 ----- ----- ----- ----- | Vac Vdc mA ±% Vdc mA ±% ±% ±mV °C |

FIGURE 1: SCHEMATIC DIAGRAM



NOTE1:
REINFORCED INSULATION SYSTEM, UL1950, IEC950, CSA-950:
 A) ALL MATERIALS MEET "UL", "CSA" & "IEC" REQUIREMENTS
 B) TRIPLE BASIC INSULATED SECONDARY.
 C) DESIGNED TO MEET ≥6.2mm CREEPAGE REQUIREMENTS.
 D) VARNISH FINISHED ASSEMBLY.
 E) UL1950 & CSA-950 CERTIFIED: FILE #E162344.
 F) UL CLASS (B) 130 INSULATION SYSTEM PM130-R1,
 PM130-H1A (UL FILE #E177139) OR ANY UL AUTHORIZED
 CLASS (B) INSULATION SYSTEM.

- (1) REFER TO APPLICATION CIRCUIT OF FIGURE 3.
- (2) SEC #1 IS REGULATED OUTPUT.
- (3) SEC #2 LOAD REGULATION TAKEN WITH SEC #1 @ 50mA Load (10%)



FIGURE 2: PHYSICAL DIMENSIONS mm (INCHES)

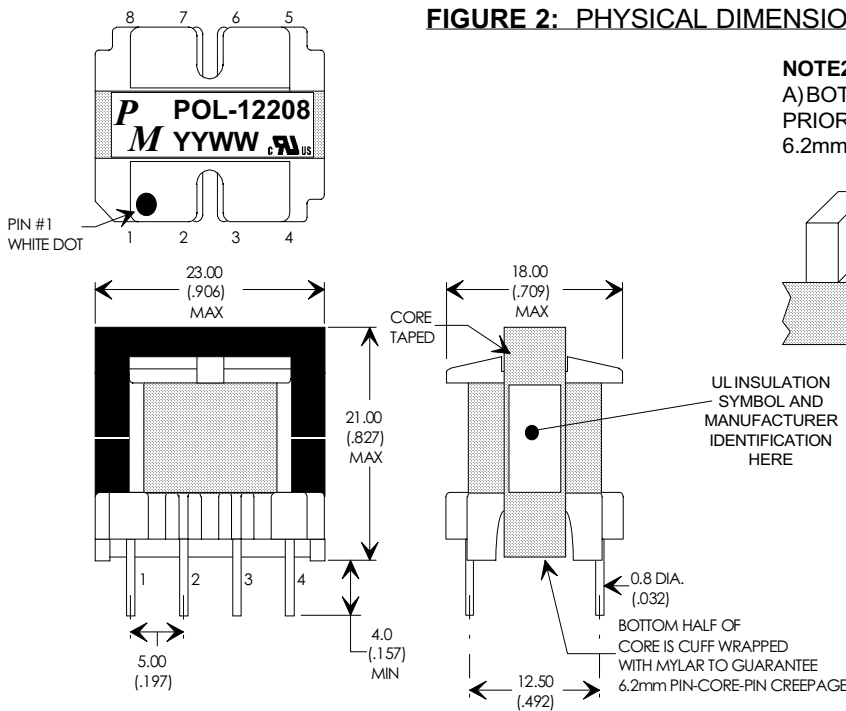

NOTE2:
 A) BOTTOM HALF OF CORE IS CUFF WRAPPED
 PRIOR TO ASSEMBLY. THIS GUARANTEES
 6.2mm CREEPAGE PIN-CORE-PIN

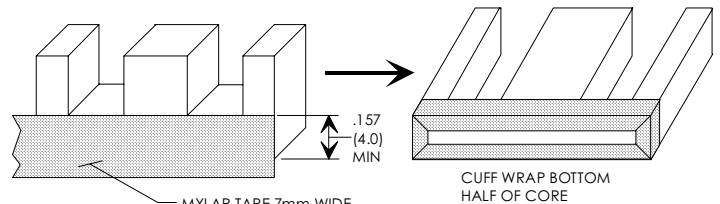

| REV. | DESCRIPTION OF CHANGES | BY |
|----------|---|----|
| 06/06/95 | ORIGINAL RELEASE | TO |
| 07/06/96 | UPDATED TO 6.2mm CREEPAGE/CLEARANCE, TOP223Y I.C. | TO |
| 05/07/99 | UPDATE TO UL CLASS (B) 130 INSULATION SYSTEM | MD |

E22/19/6, 8-PIN VERTICAL BOBBIN



UNLESS OTHERWISE SPECIFIED
 DIMENSIONS ARE IN MM
 DIMENSIONAL TOLERANCES ARE:
 DECIMALS ANGLES
 .X ± .25 ±0° 30'
 .XX ± .15
 DO NOT SCALE DRAWING

TRANSFORMER CONTROL DRAWING

| | |
|------------------------|--------------------|
| PREMIER P/N: POL-12208 | REVISION: 05/07/99 |
| DRAWN BY: TOM O'NEIL | REF: TOP223Y |
| SCALE: NONE | SHEET: 1 OF 4 |

APPLICATION NOTES

Premier Magnetics' POL-12208 Switch Mode Transformer was designed for use with Power Integrations, Inc. TOP223Y three terminal off-line PWM switching regulator in the Flyback Buck-Boost circuit configuration. This conversion topology can provide isolated multiple outputs with efficiencies up to 90%. Premier's POL-12208 transformer has been optimized to provide maximum power throughput.

The TOPXXX series from Power Integrations, Inc. are self contained 100KHz three terminal voltage controlled PWM switching regulators. This series contains all necessary functions for an off-line switched mode control DC power source. These switching regulators provide a very simple solution to off-line designs. The inductors and transformer used with the PWR-TOPXXX are critical to the performance of the circuit. They define the overall efficiency, output power and overall physical size.

Below is a universal input Dual Output 10 watt application circuit utilizing Power Integrations TOP223 switching regulator in the flyback buck-boost configuration. The component values listed are intended for reference purposes only.

FIGURE 3: TYPICAL APPLICATION CIRCUIT

