



# MEAN WELL

SWITCHING POWER SUPPLY  
ISO-9001 CERTIFIED MANUFACTURER

PT-6503

- .LOW COST, HIGH RELIABILITY
- .105°C OUTPUT CAPACITOR
- .INTERNATIONAL AC INPUT RANGE
- .HIGH EFFICIENCY, LOW WORKING TEMPERATURE
- .SOFT-START CIRCUIT, LIMITING AC SURGE CURRENT
- .SHORT CIRCUIT, OVERLOAD, OVER VOLTAGE PROTECTED
- .COMPACT SIZE, LIGHT WEIGHT
- .100% FULL LOAD BURN-IN TEST
- .BUILT IN EMI FILTER, LOW RIPPLE NOISE



MODEL	CH1	CH2	CH3
SPECIFICATION			
DC OUTPUT VOLTAGE	3.3V	5V	12V
OUTPUT V. TOLERANCE	±3%	+4,-2%	±8%
OUTPUT RATED CURRENT	6A	6A	1A
OUTPUT CURRENT RANGE	0-7A	0.2-10A	0-1.2A
RIPPLE & NOISE	50mV	50mV	100mV
LINE REGULATION	±1%	±1%	±2%
LOAD REGULATION	±3%	±3%	±8%
RATED OUTPUT POWER	TOTAL POWER MAX. 61.8W (CH1+CH2 MAX. 54W)		
EFFICIENCY	72%		
DC VOLTAGE ADJ.	CH1:3-3.6V		
INPUT VOLTAGE RANGE	90-264VAC 47-63Hz; 120-370VDC		
AC CURRENT	1.8A/115V 0.9A/230V		
INRUSH CURRENT	COLD START 20A/115V 40A/230V		
LEAKAGE CURRENT	<1mA/240VAC		
OVERLOAD PROTECTION	120-160% PULSING MODE RESET:AUTO RECOVERY		
OVER VOLTAGE PROTECTION	115%-135% ON +5V		
TEMP. COEFFICIENT	±0.03% / °C (0-50°C)		
SETUP,RISE,HOLD UP TIME	800ms, 50ms, 16ms		
VIBRATION	10-500Hz, 2G 3AXES 10min. / 1cycle ( 1 HOUR / EACH AXES )		
WITHSTAND VOLTAGE	I/P-O/P:3KVAC I/P-FG:1.5KVAC O/P-FG:0.5KVAC 1min.		
ISOLATION RESISTANCE	I/P-O/P,I/P-FG,O/P-FG:500VDC / 100M Ohms		
WORKING TEMP., HUMIDITY	-10°C~+60°C(REFER TO OUTPUT DERATING CURVE), 20%-90% RH		
STORAGE TEMP., HUMIDITY	-20°C~+85°C, 10%-95% RH		
DIMENSION	127*76.2*42mm (L*W*H) PCB ONLY		
WEIGHT	0.29Kgs		
SAFETY STANDARDS	UL1950,TUV EN60950 APPROVED		
EMC STANDARDS	EN50081-1, EN50082-1 VERIFICATION		

- NOTE :
- 1.ALL PARAMETERS ARE SPECIFIED AT 230VAC INPUT, RATED LOAD, 25°C 70% RH. AMBIENT.
  - 2.TOLERANCE INCLUDE SET UP TOLERANCE, LINE REGULATION, LOAD REGULATION.
  - 3.RIPPLE & NOISE ARE MEASURED AT 20MHz BY USING A 12" TWISTED PAIR TERMINATED WITH A 0.1uF & 47uF CAPACITOR.
  - 4.LINE REGULATION IS MEASURED FROM LOW LINE TO HIGH LINE AT RATED LOAD.
  - 5.OUTPUT PROVIDE UP TO MAXIMUM CURRENT, BUT RELATED TO MAXIMUM OUTPUT POWER.
  - 6.MOUNTING HOLES M1 AND M2 SHOULD BE GROUNDED FOR EMI PURPOSES.

2002-04-29

**BLOCK DIAGRAM**

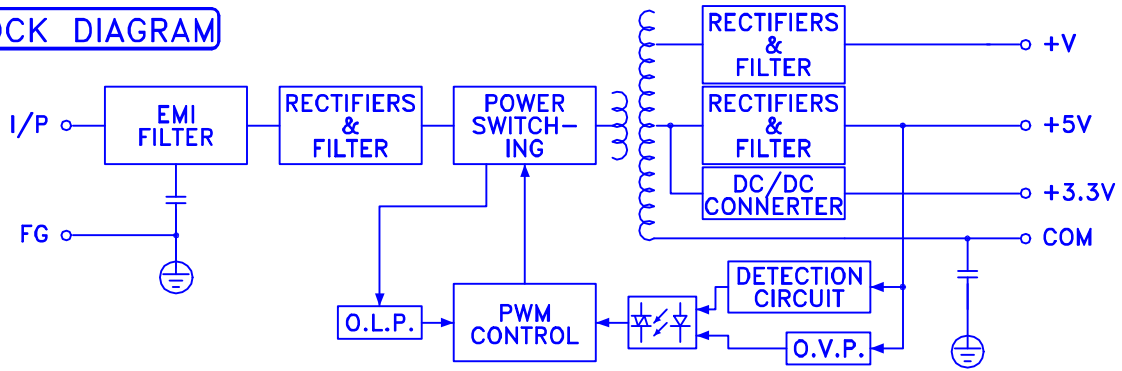

fosc : 65KHz

**OUTPUT DERATING**

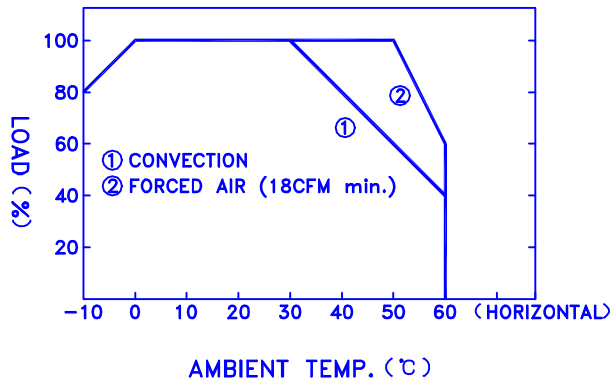

**STATIC CHARACTERISTICS**

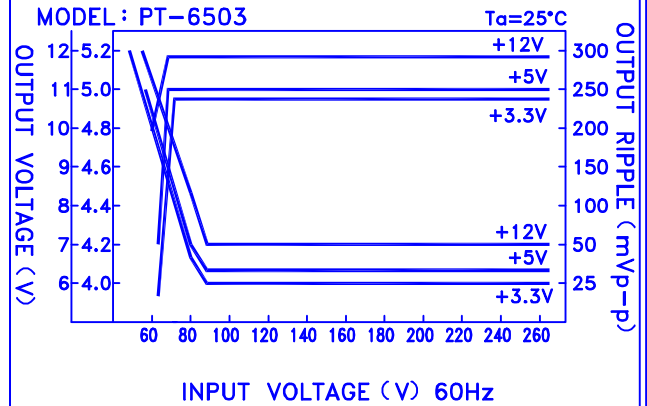

**DIMENSION (mm)**

☒ TERMINAL PIN NO. ASSIGNMENT

- ☒ CN1 : MOLEX 5277-02  
PIN 1,2 : AC INPUT
- ☒ CN2 : MOLEX 5273-08
  - ☒ PIN 1,2 : DC OUTPUT +5V
  - ☒ PIN 3,4,5: DC OUTPUT COM
  - ☒ PIN 6 : DC OUTPUT +V
  - ☒ PIN 7,8 : DC OUTPUT +3.3V

☒ MATING CONNECTORS

- ☒ CN1,2 MATING CONNECTOR TYPE MOLEX 5195 AND 5239 SERIES OR EQUIVALENT WITH MOLEX 5194 AND 5225 OR EQUIVALENT CRIMP TERMINALS.

