



800mA and 1A Low Dropout Positive Regulator 1.8V, 2.5V, 2.85V, 3.3V, 5V, and Adjustable

FEATURES

- FIXED AND ADJUSTABLE VERSIONS
- 2.85V MODEL FOR SCSI-2 ACTIVE TERMINATION
- OUTPUT CURRENT:
REG1117: 800mA max
REG1117A: 1A max
- OUTPUT TOLERANCE: $\pm 1\%$ max
- DROPOUT VOLTAGE:
REG1117: 1.2V max at $I_O = 800\text{mA}$
REG1117A: 1.3V max at $I_O = 1\text{A}$
- INTERNAL CURRENT LIMIT
- THERMAL OVERLOAD PROTECTION
- SOT-223 AND DDPK SURFACE-MOUNT PACKAGES

APPLICATIONS

- SCSI-2 ACTIVE TERMINATION
- HAND-HELD DATA COLLECTION DEVICES
- HIGH EFFICIENCY LINEAR REGULATORS
- BATTERY POWERED INSTRUMENTATION
- BATTERY MANAGEMENT CIRCUITS FOR NOTEBOOK AND PALMTOP PCs
- CORE VOLTAGE SUPPLY: FPGA, PLD, DSP, CPU

DESCRIPTION

The REG1117 is a family of easy-to-use three-terminal voltage regulators. The family includes a variety of fixed- and adjustable-voltage versions, two currents (800mA and 1A) and two package types (SOT-223 and DDPK). See the chart below for available options.

Output voltage of the adjustable versions is set with two external resistors. The REG1117's low dropout voltage allows its use with as little as 1V input-output voltage differential.

Laser trimming assures excellent output voltage accuracy without adjustment. An NPN output stage allows output stage drive to contribute to the load current for maximum efficiency.

VOLTAGE	800mA		1A	
	SOT-223	DDPAK	SOT-223	DDPAK
1.8V			✓	✓
2.5V			✓	✓
2.85V	✓			
3.3V	✓	✓		
5V	✓			✓
Adj.	✓		✓	✓



Please be aware that an important notice concerning availability, standard warranty, and use in critical applications of Texas Instruments semiconductor products and disclaimers thereto appears at the end of this data sheet.

PACKAGE/ORDERING INFORMATION

PRODUCT	V _O /I _O	PACKAGE-LEAD	PACKAGE DESIGNATOR	SPECIFIED TEMPERATURE RANGE	PACKAGE MARKING	ORDERING NUMBER	TRANSPORT MEDIA, QUANTITY
800mA Output							
REG1117-2.85	2.85/800mA	SOT223-3	DCY	0°C to +125°C	BB11172	REG1117-2.85	Rails, 80
"	"/"/"	"	"	"	"	REG1117-2.85	Tape and Reel, 2500
REG1117-3.3	3.3/800mA	SOT223-3	DCY	0°C to +125°C	BB11174	REG1117-3.3	Rails, 80
"	"/"/"	"	"	"	"	REG1117-3.3	Tape and Reel, 2500
REG1117F-3.3	3.3/800mA	DDPAK-3	KTT	0°C to +125°C	BB1117F4	REG1117F-3.3	Rails, 49
"	"/"/"	"	"	"	"	REG1117F-3.3	Tape and Reel, 500
REG1117-5	5V/800mA	SOT223-3	DCY	0°C to +125°C	BB11175	REG1117-5	Rails, 80
"	"/"/"	"	"	"	"	REG1117-5	Tape and Reel, 2500
REG1117	Adj./800mA	SOT223-3	DCY	0°C to +125°C	BB1117	REG1117	Rails, 80
"	"/"/"	"	"	"	"	REG1117	Tape and Reel, 2500
1A Output							
REG1117A-1.8	1.8V/1A	SOT223-3	DCY	0°C to +125°C	R111718	REG1117A-1.8	Rails, 80
"	"/"/"	"	"	"	"	REG1117A-1.8	Tape and Reel, 2500
REG1117FA-1.8	1.8/1A	DDPAK-3	KTT	0°C to +125°C	REG1117FA1.8	REG1117FA-1.8	Rails, 49
"	"/"/"	"	"	"	"	REG1117FA-1.8	Tape and Reel, 500
REG1117A-2.5	2.5/1A	SOT223-3	DCY	0°C to +125°C	R111725	REG1117A-2.5	Rails, 80
"	"/"/"	"	"	"	"	REG1117A-2.5	Tape and Reel, 2500
REG1117FA-2.5	2.5/1A	DDPAK-3	KTT	0°C to +125°C	REG1117FA2.5	REG1117FA-2.5	Rails, 49
"	"/"/"	"	"	"	"	REG1117FA-2.5	Tape and Reel, 500
REG1117FA-5	5/1A	DDPAK-3	KTT	0°C to +125°C	REG1117FA5.0	REG1117FA-5.0	Rails, 49
"	"/"/"	"	"	"	"	REG1117FA-5.0	Tape and Reel, 500
REG1117A	Adj./1A	SOT223-3	DCY	0°C to +125°C	BB1117A	REG1117A	Rails, 80
"	"/"/"	"	"	"	"	REG1117A	Tape and Reel, 2500
REG1117FA	Adj./1A	DDPAK-3	KTT	0°C to +125°C	REG1117FA	REG1117FA	Rails, 49
"	"/"/"	"	"	"	"	REG1117FA	Tape and Reel, 500

ABSOLUTE MAXIMUM RATINGS⁽¹⁾

Power Dissipation	Internally Limited
Input Voltage	15V
Operating Junction Temperature Range	0°C to +125°C
Storage Temperature Range	-65°C to +150°C
Lead Temperature (soldering, 10s) ⁽²⁾	+300°C

NOTE: (1) Stresses above these ratings may cause permanent damage. (2) See "Soldering Methods."

CONNECTION DIAGRAM

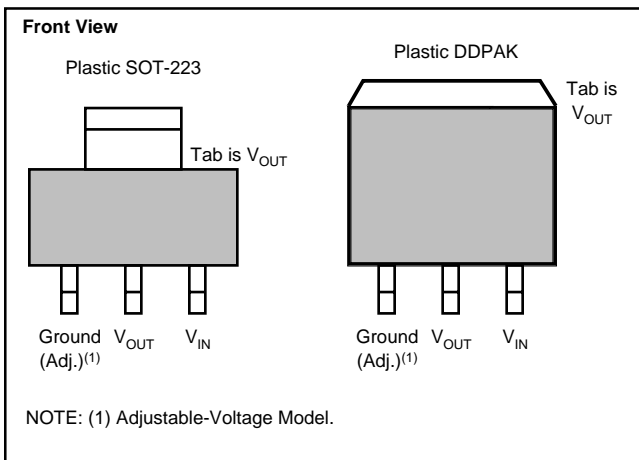

ELECTROSTATIC DISCHARGE SENSITIVITY

This integrated circuit can be damaged by ESD. Texas Instruments recommends that all integrated circuits be handled with appropriate precautions. Failure to observe proper handling and installation procedures can cause damage.

ESD damage can range from subtle performance degradation to complete device failure. Precision integrated circuits may be more susceptible to damage because very small parametric changes could cause the device not to meet its published specifications.

ELECTRICAL CHARACTERISTICS

At $T_J = +25^\circ\text{C}$, unless otherwise noted.

PARAMETER	CONDITIONS	REG1117, REG1117A			UNITS
		MIN	TYP	MAX	
OUTPUT VOLTAGE					
REG1117-2.85 See Note 1	$I_O = 10\text{mA}$, $V_{IN} = 4.85\text{V}$ $I_O = 0$ to 800mA , $V_{IN} = 4.05$ to 10V	2.820 2.790	2.85 2.85	2.880 2.910	V V
REG1117-3.3 See Note 1	$I_O = 10\text{mA}$, $V_{IN} = 5.3\text{V}$ $I_O = 0$ to 800mA , $V_{IN} = 4.8$ to 10V	3.270 3.240	3.30 3.30	3.330 3.360	V V
REG1117-5 See Note 1	$I_O = 10\text{mA}$, $V_{IN} = 7\text{V}$ $I_O = 0$ to 800mA , $V_{IN} = 6.5$ to 10V	4.950 4.900	5.00 5.00	5.050 5.100	V V
REG1117A-1.8 See Note 1	$I_O = 10\text{mA}$, $V_{IN} = 3.8\text{V}$ $I_O = 0$ to 1A , $V_{IN} = 3.8\text{V}$ to 10V	1.782 1.764	1.8 1.8	1.818 1.836	V V
REG1117A-2.5 See Note 1	$I_O = 10\text{mA}$, $V_{IN} = 4.5\text{V}$ $I_O = 0$ to 1A , $V_{IN} = 4.5\text{V}$ to 10V	2.475 2.450	2.5 2.5	2.525 2.550	V V
REG1117A-5 See Note 1	$I_O = 10\text{mA}$, $V_{IN} = 7\text{V}$ $I_O = 0$ to 1A , $V_{IN} = 7\text{V}$ to 10V	4.950 4.900	5.0 5.0	5.050 5.100	V V
REFERENCE VOLTAGE					
REG1117 (Adjustable) See Note 1	$I_O = 10\text{mA}$, $V_{IN} - V_O = 2\text{V}$ $I_O = 10$ to 800mA , $V_{IN} - V_O = 1.4$ to 10V	1.238 1.225	1.250 1.250	1.262 1.280	V V
REG1117A (Adjustable) See Note 1	$I_O = 10\text{mA}$, $V_{IN} - V_O = 2\text{V}$ $I_O = 10\text{mA}$ to 1A , $V_{IN} - V_O = 1.4$ to 10V	1.238 1.225	1.250 1.250	1.262 1.280	V V
LINE REGULATION					
REG1117-2.85 ⁽¹⁾	$I_O = 0$, $V_{IN} = 4.25$ to 10V		1	7	mV
REG1117-3.3 ⁽¹⁾	$I_O = 0$, $V_{IN} = 4.8$ to 10V		2	7	mV
REG1117-5 ⁽¹⁾	$I_O = 0$, $V_{IN} = 6.5$ to 15V		3	10	mV
REG1117 (Adjustable) ⁽¹⁾	$I_O = 10\text{mA}$, $V_{IN} - V_O = 1.5$ to 13.75V		0.1	0.4	%
REG1117A (Adjustable) ⁽¹⁾	$I_O = 10\text{mA}$, $V_{IN} - V_O = 1.5$ to 13.75V		0.1	0.4	%
REG1117A-1.8 ⁽¹⁾	$I_O = 0$, $V_{IN} = 3.8\text{V}$ to 10V		1	7	mV
REG1117A-2.5 ⁽¹⁾	$I_O = 0$, $V_{IN} = 4.5\text{V}$ to 10V		1	7	mV
REG1117A-5.0 ⁽¹⁾	$I_O = 0$, $V_{IN} = 7\text{V}$ to 15V		3	10	mV
LOAD REGULATION					
REG1117-2.85 ⁽¹⁾	$I_O = 0$ to 800mA , $V_{IN} = 4.25\text{V}$		2	10	mV
REG1117-3.3 ⁽¹⁾	$I_O = 0$ to 800mA , $V_{IN} = 4.8\text{V}$		3	12	mV
REG1117-5 ⁽¹⁾	$I_O = 0$ to 800mA , $V_{IN} = 6.5\text{V}$		3	15	mV
REG1117 (Adjustable) ⁽¹⁾⁽²⁾	$I_O = 10$ to 800mA , $V_{IN} - V_O = 3\text{V}$		0.1	0.4	%
REG1117A (Adjustable) ⁽¹⁾⁽²⁾	$I_O = 10\text{mA}$ to 1A , $V_{IN} - V_O = 3\text{V}$		0.1	0.4	%
REG1117A-1.8	$I_O = 0$ to 1A , $V_{IN} = 3.8\text{V}$		2	10	mV
REG1117A-2.5	$I_O = 0$ to 1A , $V_{IN} = 4.5\text{V}$		2	10	mV
REG1117A-5	$I_O = 0$ to 1A , $V_{IN} = 7.0\text{V}$		3	15	mV
DROPOUT VOLTAGE⁽³⁾					
All Models ⁽¹⁾ See Note 1	$I_O = 100\text{mA}$ $I_O = 500\text{mA}$		1.00 1.05	1.10 1.15	V V
REG1117 Models ⁽¹⁾	$I_O = 800\text{mA}$		1.10	1.20	V
REG1117A See Note 1	$I_O = 1\text{A}$ $I_O = 1\text{A}$		1.2 1.2	1.30 1.55	V V
CURRENT LIMIT					
REG1117 Models REG1117A	$V_{IN} - V_O = 5\text{V}$ $V_{IN} - V_O = 5\text{V}$	800 1000	950 1250	1200 1600	mA mA
MINIMUM LOAD CURRENT Adjustable Models ⁽¹⁾⁽²⁾	$V_{IN} - V_O = 13.75\text{V}$		1.7	5	mA
QUIESCENT CURRENT Fixed-Voltage Models ⁽¹⁾	$V_{IN} - V_O = 5\text{V}$		4	10	mA
Adjust Pin Current⁽¹⁾⁽²⁾ vs Load Current, REG1117 ⁽¹⁾ vs Load Current, REG1117A ⁽¹⁾	$I_O = 10\text{mA}$, $V_{IN} - V_O = 1.4$ to 10V $I_O = 10\text{mA}$ to 800mA , $V_{IN} - V_O = 1.4$ to 10V $I_O = 10\text{mA}$ to 1A , $V_{IN} - V_O = 1.4$ to 10V		50 0.5 0.5	120 5 5	μA μA μA
THERMAL REGULATION All Models ⁽⁴⁾	30ms Pulse		0.01	0.1	%/W
RIPPLE REJECTION All Models	$f = 120\text{Hz}$, $V_{IN} - V_{OUT} = 3\text{V} + 1\text{Vp-p}$ Ripple		62		dB
TEMPERATURE DRIFT Fixed-Voltage Models Adjustable Models	$T_J = 0^\circ\text{C}$ to $+125^\circ\text{C}$ $T_J = 0^\circ\text{C}$ to $+125^\circ\text{C}$		0.5 2		% %

ELECTRICAL CHARACTERISTICS (Cont.)

At $T_J = +25^\circ\text{C}$, unless otherwise noted.

PARAMETER	CONDITIONS	REG1117, REG1117A			UNITS
		MIN	TYP	MAX	
LONG-TERM STABILITY All Models	$T_A = +125^\circ\text{C}$, 1000Hr		0.3		%
OUTPUT NOISE rms Noise, All Models	$f = 10\text{Hz}$ to 10kHz		0.003		%
THERMAL RESISTANCE Operating Junction Temperature Range		0		+125	$^\circ\text{C}$
Storage Range		-65		+150	$^\circ\text{C}$
Thermal Resistance, θ_{JC} 3-Lead SOT-223 Surface-Mount	(Junction-to-Case at Tab)		15		$^\circ\text{C/W}$
3-Lead DDPAK Surface-Mount	$f > 50\text{Hz}$		2		$^\circ\text{C/W}$
	dc		3		$^\circ\text{C/W}$
Thermal Resistance, θ_{JA} 3-Lead DDPAK Surface-Mount	(Junction-to-Case at Tab) No Heat Sink		65		$^\circ\text{C/W}$

NOTES: (1) Specification applies over the full operating Junction temperature range, 0°C to $+125^\circ\text{C}$. (2) REG1117 and REG1117A adjustable versions require a minimum load current for $\pm 3\%$ regulation. (3) Dropout voltage is the input voltage minus output voltage that produces a 1% decrease in output voltage. (4) Percentage change in unloaded output voltage before versus after a 30ms power pulse of $I_O = 800\text{mA}$ (REG1117 models), $I_O = 1\text{A}$ (REG1117A), $V_{IN} - V_O = 1.4\text{V}$ (Reading taken 10ms after pulse).

SIMPLIFIED SCHEMATIC

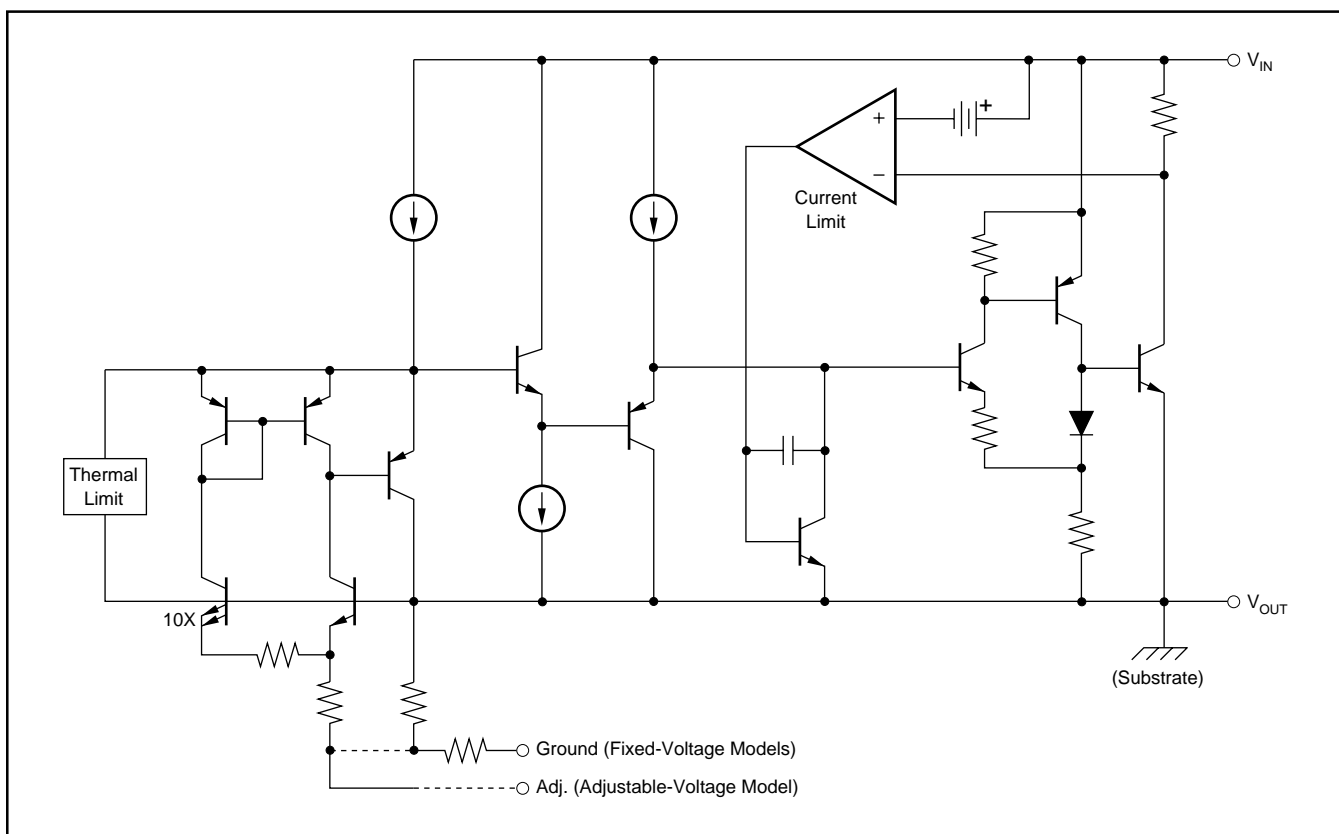

TYPICAL CHARACTERISTICS

At $T_J = +25^\circ\text{C}$, all models, unless otherwise specified.

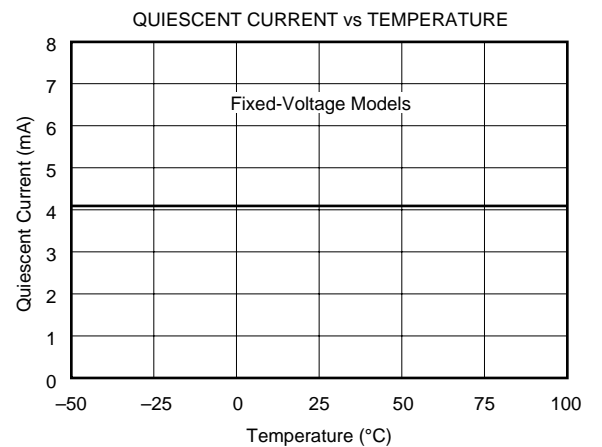
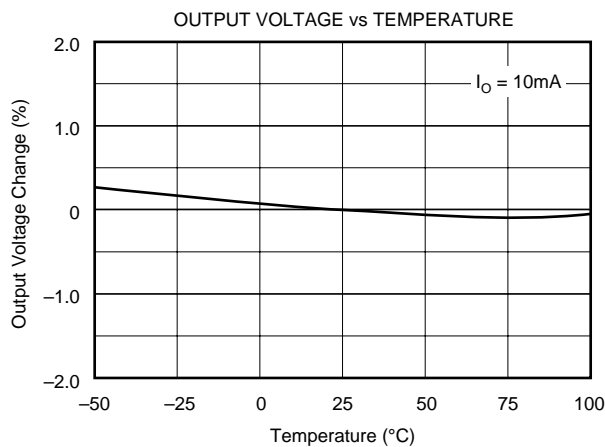
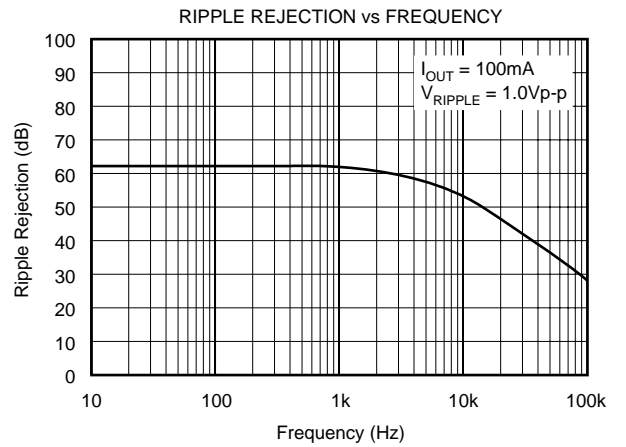
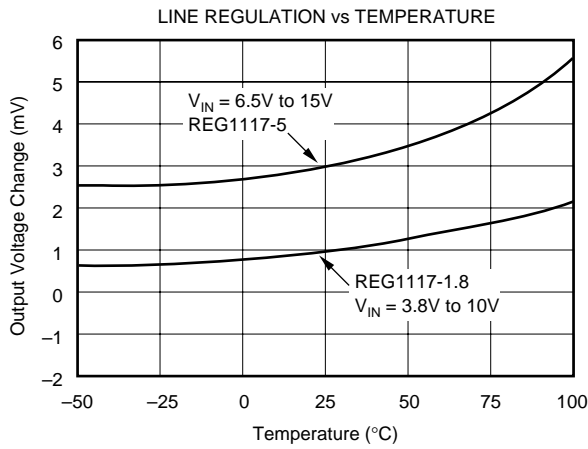
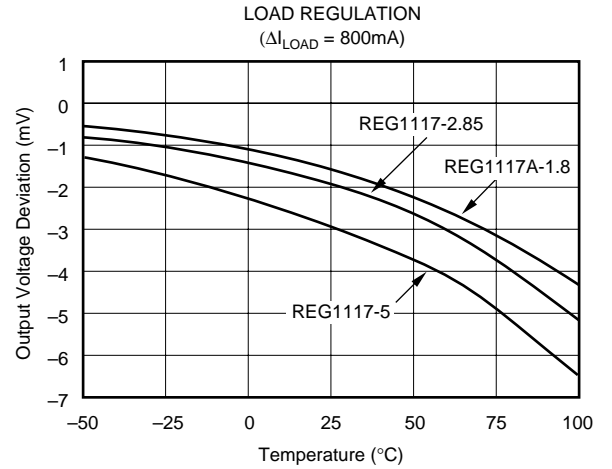
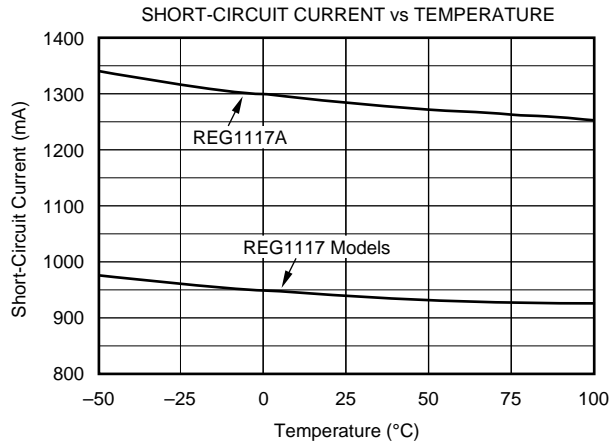

TYPICAL CHARACTERISTICS (Cont.)

At $T_j = +25^\circ\text{C}$, all models, unless otherwise specified.

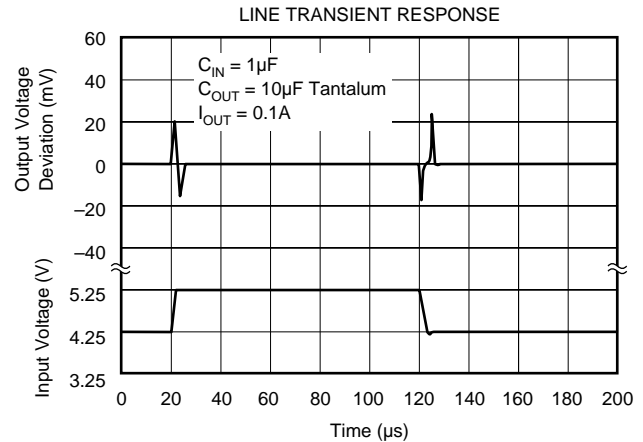
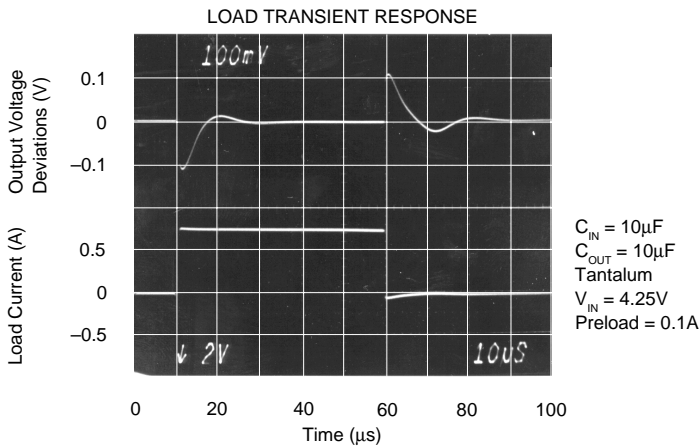

APPLICATIONS INFORMATION

Figure 1 shows the basic hookup diagram for fixed-voltage models. All models require an output capacitor for proper operation and to improve high frequency load regulation. A $10\mu\text{F}$ tantalum capacitor is recommended. Aluminum electrolytic types of $50\mu\text{F}$ or greater can also be used. A high quality capacitor should be used to assure that the ESR (Effective Series Resistance) is less than 0.5Ω .

Figure 2 shows a hookup diagram for the adjustable voltage model. Resistor values are shown for some commonly used output voltages. Values for other voltages can be calculated from the equation shown in Figure 2. For best load regulation, connect R_1 close to the output pin and R_2 close to the ground side of the load as shown.

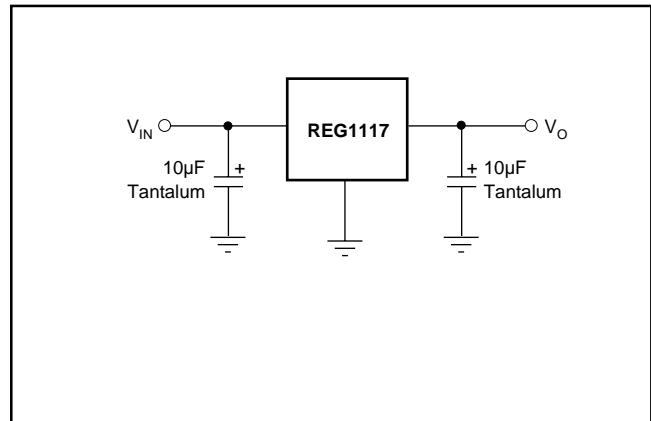

FIGURE 1. Fixed-Voltage Model—Basic Connections.

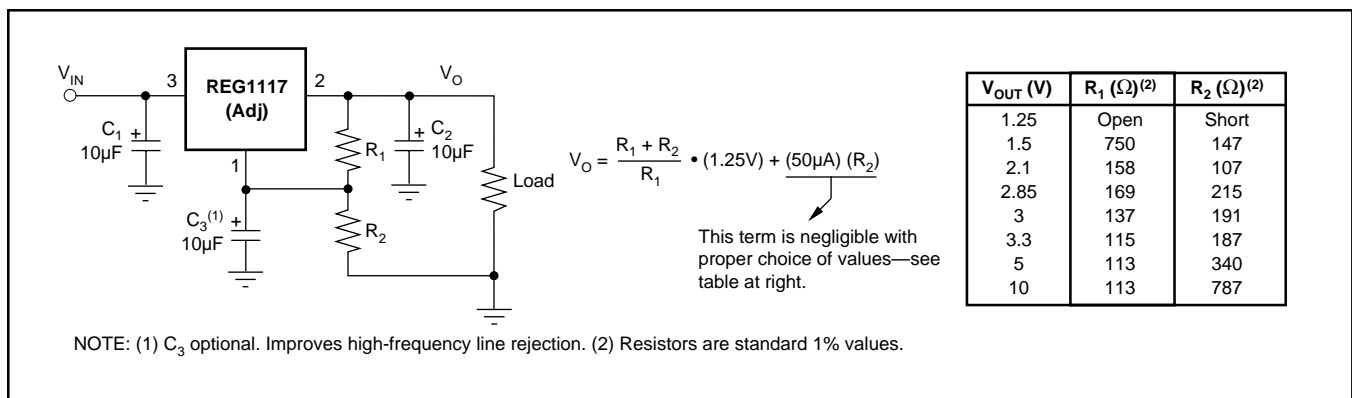

FIGURE 2. Adjustable-Voltage Model—Basic Connections.

THERMAL CONSIDERATIONS

The REG1117 has current limit and thermal shutdown circuits that protect it from overload. The thermal shutdown activates at approximately $T_J = 165^\circ\text{C}$. For continuous operation, however, the junction temperature should not be allowed to exceed 125°C . Any tendency to activate the thermal shutdown in normal use is an indication of an inadequate heat sink or excessive power dissipation. The power dissipation is equal to:

$$P_D = (V_{IN} - V_{OUT}) I_{OUT}$$

The junction temperature can be calculated by:

$$T_J = T_A + P_D (\theta_{JA})$$

where T_A is the ambient temperature, and θ_{JA} is the junction-to-ambient thermal resistance

A simple experiment will determine whether the maximum recommended junction temperature is exceeded in an actual circuit board and mounting configuration: Increase the ambient temperature above that expected in normal operation

until the device's thermal shutdown is activated. If this occurs at more than 40°C above the maximum expected ambient temperature, then the T_J will be less than 125°C during normal operation.

The internal protection circuitry of the REG1117 was designed to protect against overload conditions. It was not intended to replace proper heat sinking. Continuously running the REG1117 into thermal shutdown will degrade reliability.

LAYOUT CONSIDERATIONS

The DDPAK (REG1117F-3.3 and REG1117FA) is a surface-mount power package that has excellent thermal characteristics. For best thermal performance, its mounting tab should be soldered directly to a circuit board copper area, as shown in Figure 3. Increasing the copper area improves heat dissipation. Figure 4 shows typical thermal resistance from junction-to-ambient as a function of the copper area.

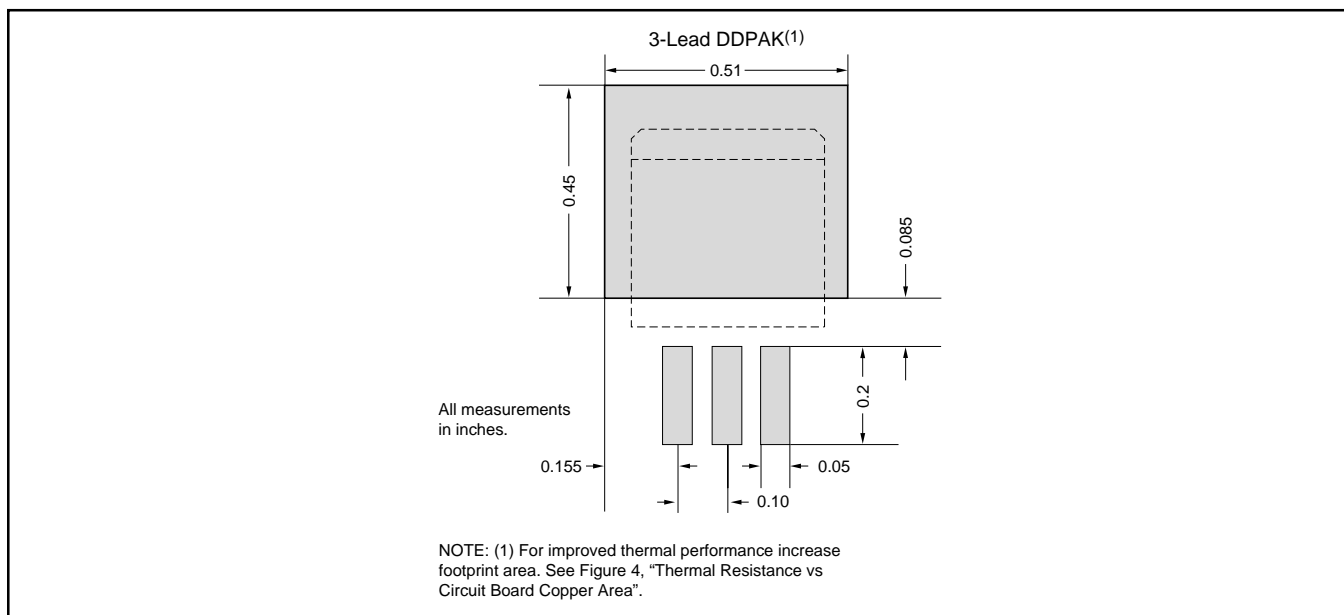

FIGURE 3. DDPAK Thermal Resistance versus Circuit Board Copper Area.

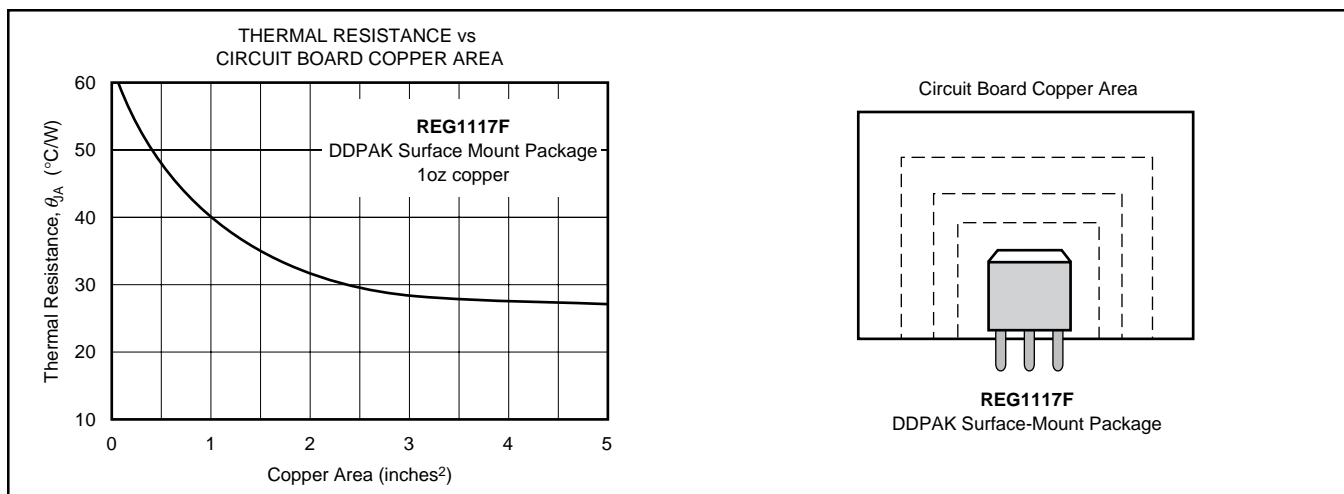

FIGURE 4. DDPAK Thermal Resistance versus Circuit Board Copper Area.

The SOT-223 package derives heat sinking from conduction through its copper leads, especially the large mounting tab. These must be soldered to a circuit board with a substantial amount of copper remaining, as shown in Figure 5. Circuit board traces connecting the tab and the leads should be made as large as practical. The mounting tab of both packages is electrically connected to V_{OUT} .

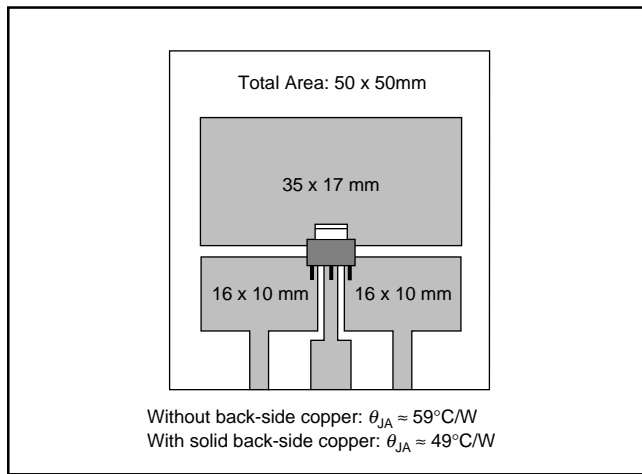

FIGURE 5. SOT-223 Circuit Board Layout Example.

Other nearby circuit traces, including those on the back side of the circuit board, help conduct heat away from the device, even though they may not be electrically connected. Make all nearby copper traces as wide as possible and leave only narrow gaps between traces.

Table I shows approximate values of θ_{JA} for various circuit board and copper areas for the SOT-223 package. Nearby heat dissipating components, circuit board mounting conditions, and ventilation can dramatically affect the actual θ_{JA} . Proper heat sinking significantly increases the maximum power dissipation at a given ambient temperature, as shown in Figure 6.

SOLDERING METHODS

Both REG1117 packages are suitable for infrared reflow and vapor-phase reflow soldering techniques. The high rate of temperature change that occurs with wave soldering, or hand soldering can damage the REG1117.

TOTAL PC BOARD AREA	TOPSIDE ⁽¹⁾ COPPER AREA	BACKSIDE COPPER AREA	SOT-223 THERMAL RESISTANCE JUNCTION-TO-AMBIENT
2500mm ²	2500mm ²	2500mm ²	46°C/W
2500mm ²	1250mm ²	2500mm ²	47°C/W
2500mm ²	950mm ²	2500mm ²	49°C/W
2500mm ²	2500mm ²	0	51°C/W
2500mm ²	1800mm ²	0	53°C/W
1600mm ²	600mm ²	1600mm ²	55°C/W
2500mm ²	1250mm ²	0	58°C/W
2500mm ²	915mm ²	0	59°C/W
1600mm ²	600mm ²	0	67°C/W
900mm ²	340mm ²	900mm ²	72°C/W
900mm ²	340mm ²	0	85°C/W

NOTE: (1) Tab is attached to the topside copper.

TABLE I.

INSPEC Abstract Number: B91007604, C91012627
 Kelly, E.G. "Thermal Characteristics of Surface 5WK9Ω Packages." The Proceedings of SMTCON. Surface Mount Technology Conference and Exposition: *Competitive Surface Mount Technology*, April 3-6, 1990, Atlantic City, NJ, USA. Abstract Publisher: IC Manage, 1990, Chicago, IL, USA.

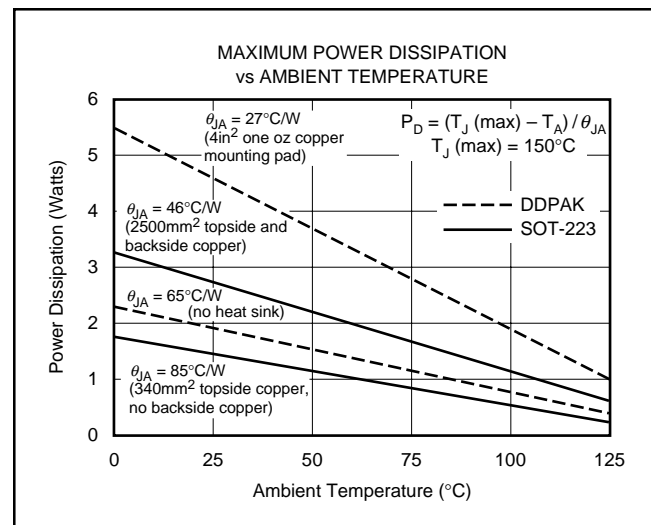

FIGURE 6. Maximum Power Dissipation versus Ambient Temperature.

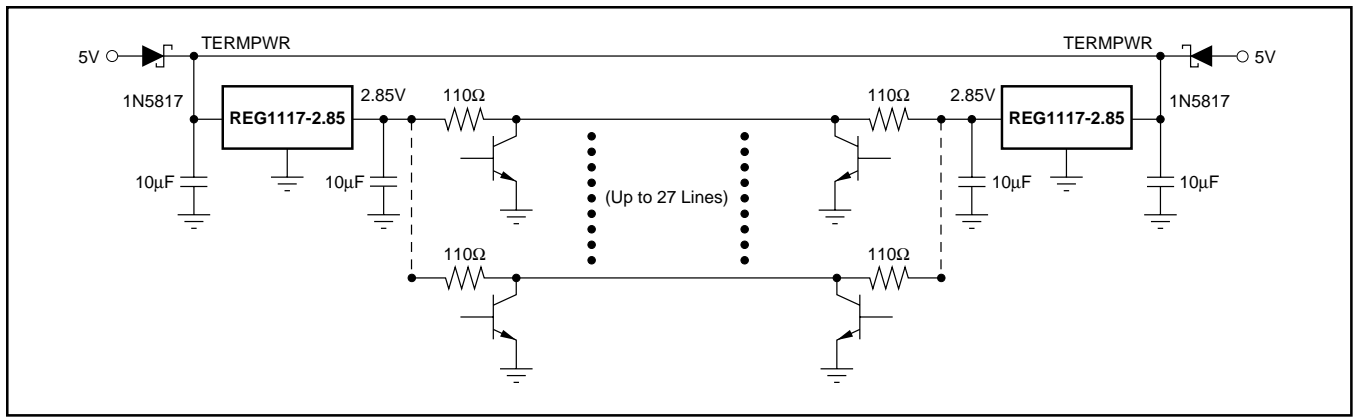

FIGURE 7. SCSI Active Termination Configuration.

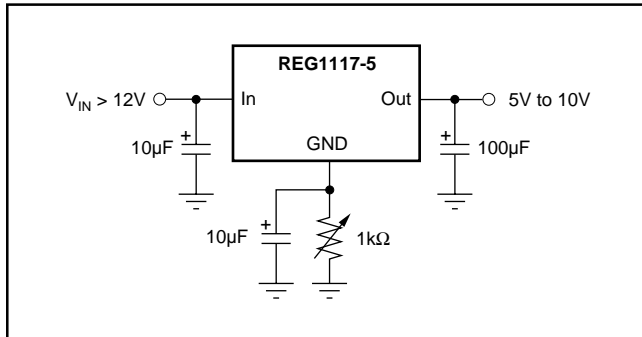

FIGURE 8. Adjusting Output of Fixed Voltage Models.

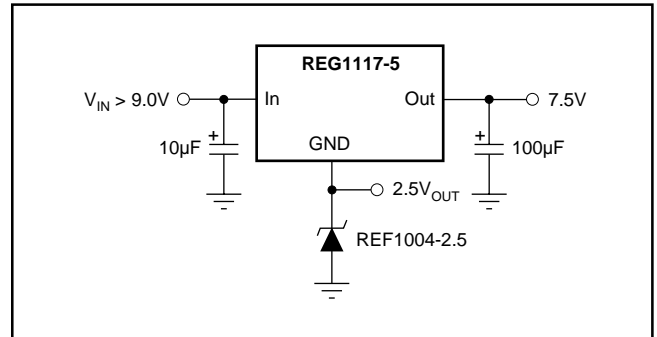

FIGURE 9. Regulator with Reference.

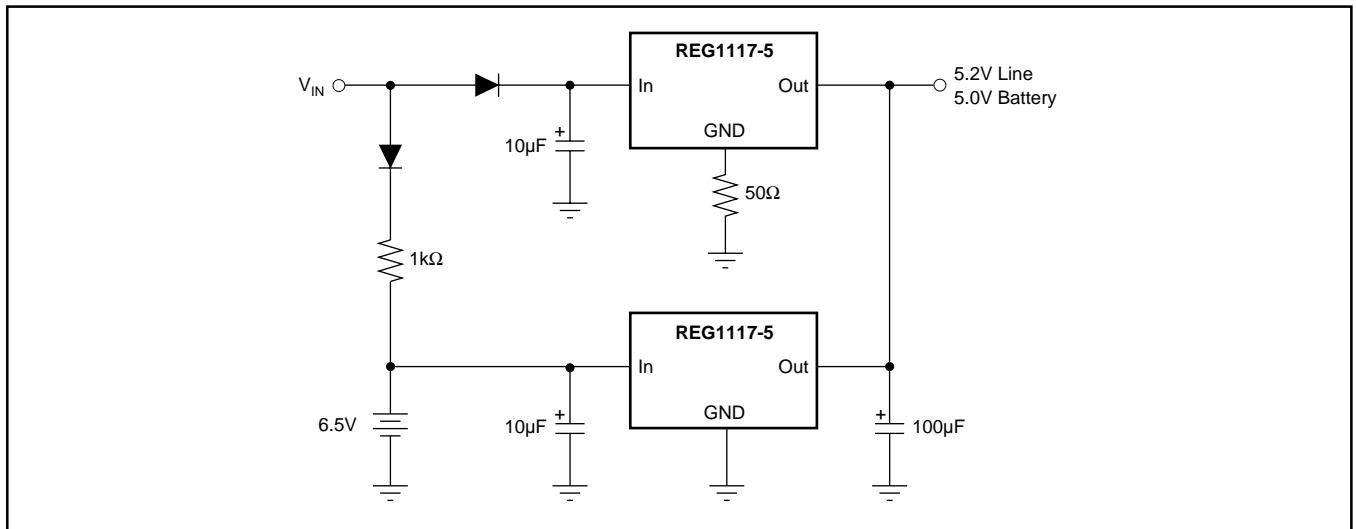

FIGURE 10. Battery Backed-Up Regulated Supply.

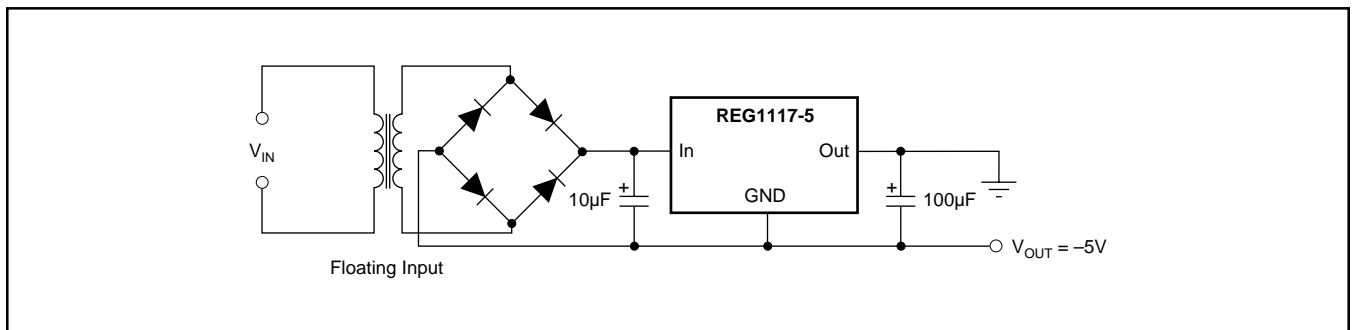
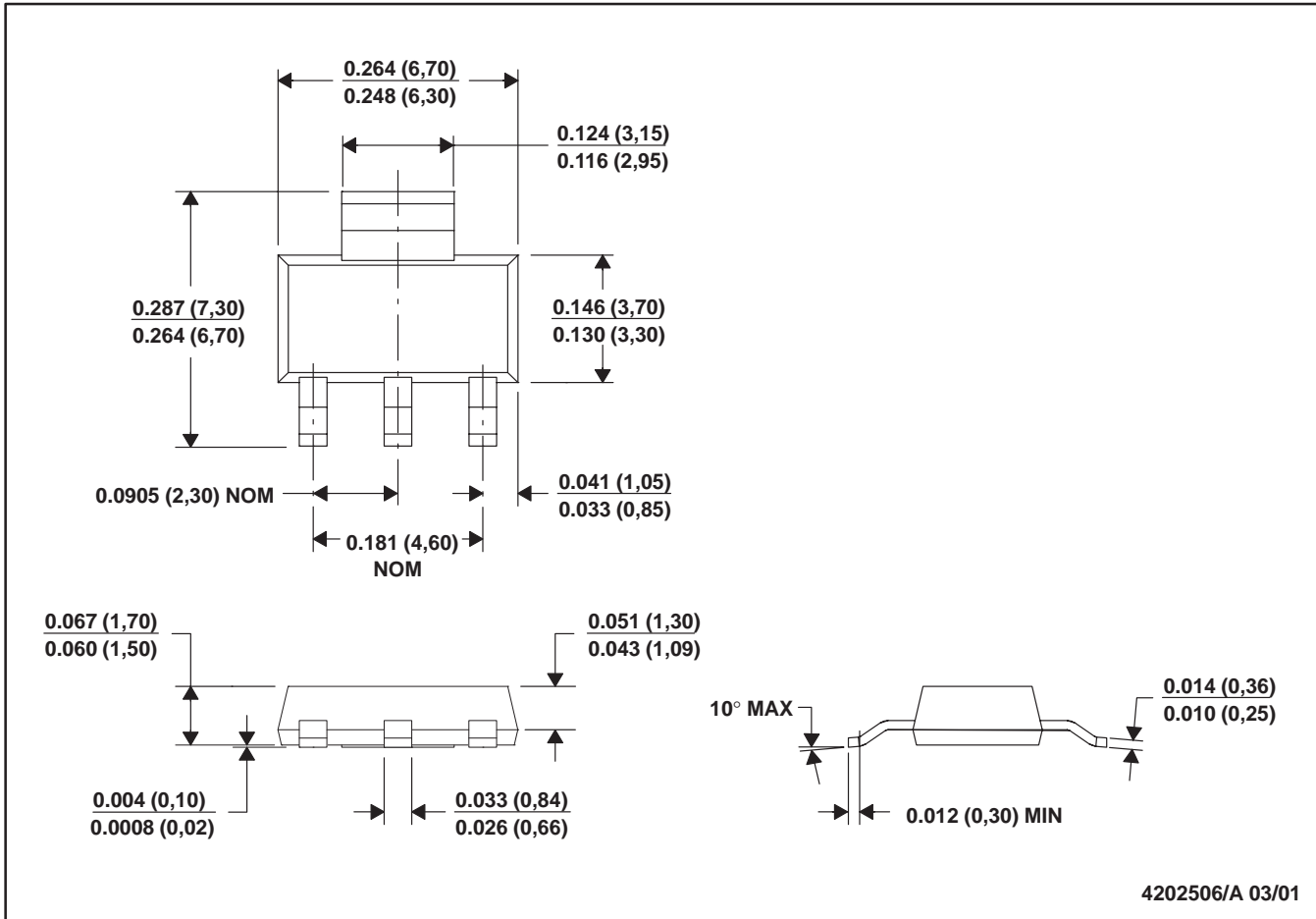

FIGURE 11. Low Dropout Negative Supply.

DCY (R-PDSO-G4)

PLASTIC SMALL-OUTLINE



NOTES: A. All linear dimensions are in inches (millimeters).
 B. This drawing is subject to change without notice.

KTT (R-PSFM-G3)

PLASTIC FLANGE-MOUNT

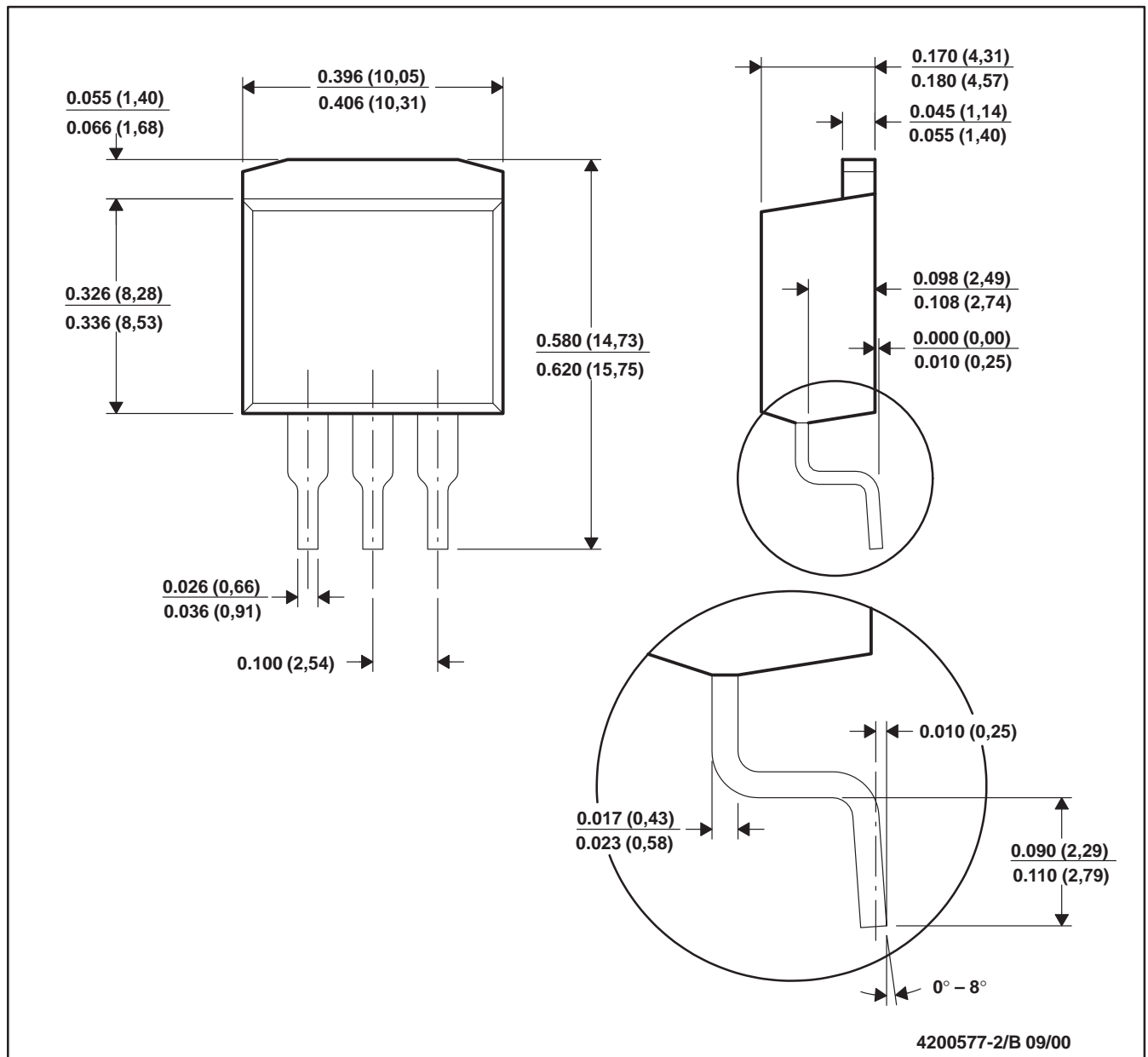

- NOTES: A. All linear dimensions are in millimeters.
 B. This drawing is subject to change without notice.
 C. Dimensions do not include mold protrusions, not to exceed 0.006 (0,15).

PACKAGING INFORMATION

ORDERABLE DEVICE	STATUS(1)	PACKAGE TYPE	PACKAGE DRAWING	PINS	PACKAGE QTY
REG1117	ACTIVE	SOP	DCY	4	80
REG1117-2.85	ACTIVE	SOP	DCY	4	80
REG1117-2.85/2K5	ACTIVE	SOP	DCY	4	2500
REG1117-3.3	ACTIVE	SOP	DCY	4	80
REG1117-3.3/2K5	ACTIVE	SOP	DCY	4	2500
REG1117-5	ACTIVE	SOP	DCY	4	80
REG1117-5/2K5	ACTIVE	SOP	DCY	4	2500
REG1117/2K5	ACTIVE	SOP	DCY	4	2500
REG1117A	ACTIVE	SOP	DCY	4	80
REG1117A-1.8	ACTIVE	SOP	DCY	4	80
REG1117A-1.8/2K5	ACTIVE	SOP	DCY	4	2500
REG1117A-2.5	ACTIVE	SOP	DCY	4	80
REG1117A-2.5/2K5	ACTIVE	SOP	DCY	4	2500
REG1117A/2K5	ACTIVE	SOP	DCY	4	2500
REG1117F-3.3	ACTIVE	PFM	KTT	3	49
REG1117F-3.3/500	ACTIVE	PFM	KTT	3	500
REG1117F-3.3KTTT	ACTIVE	PFM	KTT	3	50
REG1117FA	ACTIVE	PFM	KTT	3	49
REG1117FA-1.8	ACTIVE	PFM	KTT	3	49
REG1117FA-1.8/500	ACTIVE	PFM	KTT	3	500
REG1117FA-2.5	ACTIVE	PFM	KTT	3	49
REG1117FA-2.5/500	ACTIVE	PFM	KTT	3	500
REG1117FA-5.0	ACTIVE	PFM	KTT	3	49
REG1117FA-5.0/500	ACTIVE	PFM	KTT	3	500
REG1117FA/500	ACTIVE	PFM	KTT	3	500

(1) The marketing status values are defined as follows:

ACTIVE: Product device recommended for new designs.

LIFEBUY: TI has announced that the device will be discontinued, and a lifetime-buy period is in effect.

NRND: Not recommended for new designs. Device is in production to support existing customers, but TI does not recommend using this part in a new design.

PREVIEW: Device has been announced but is not in production. Samples may or may not be available.

OBSOLETE: TI has discontinued the production of the device.

IMPORTANT NOTICE

Texas Instruments Incorporated and its subsidiaries (TI) reserve the right to make corrections, modifications, enhancements, improvements, and other changes to its products and services at any time and to discontinue any product or service without notice. Customers should obtain the latest relevant information before placing orders and should verify that such information is current and complete. All products are sold subject to TI's terms and conditions of sale supplied at the time of order acknowledgment.

TI warrants performance of its hardware products to the specifications applicable at the time of sale in accordance with TI's standard warranty. Testing and other quality control techniques are used to the extent TI deems necessary to support this warranty. Except where mandated by government requirements, testing of all parameters of each product is not necessarily performed.

TI assumes no liability for applications assistance or customer product design. Customers are responsible for their products and applications using TI components. To minimize the risks associated with customer products and applications, customers should provide adequate design and operating safeguards.

TI does not warrant or represent that any license, either express or implied, is granted under any TI patent right, copyright, mask work right, or other TI intellectual property right relating to any combination, machine, or process in which TI products or services are used. Information published by TI regarding third-party products or services does not constitute a license from TI to use such products or services or a warranty or endorsement thereof. Use of such information may require a license from a third party under the patents or other intellectual property of the third party, or a license from TI under the patents or other intellectual property of TI.

Reproduction of information in TI data books or data sheets is permissible only if reproduction is without alteration and is accompanied by all associated warranties, conditions, limitations, and notices. Reproduction of this information with alteration is an unfair and deceptive business practice. TI is not responsible or liable for such altered documentation.

Resale of TI products or services with statements different from or beyond the parameters stated by TI for that product or service voids all express and any implied warranties for the associated TI product or service and is an unfair and deceptive business practice. TI is not responsible or liable for any such statements.

Following are URLs where you can obtain information on other Texas Instruments products and application solutions:

Products		Applications	
Amplifiers	amplifier.ti.com	Audio	www.ti.com/audio
Data Converters	dataconverter.ti.com	Automotive	www.ti.com/automotive
DSP	dsp.ti.com	Broadband	www.ti.com/broadband
Interface	interface.ti.com	Digital Control	www.ti.com/digitalcontrol
Logic	logic.ti.com	Military	www.ti.com/military
Power Mgmt	power.ti.com	Optical Networking	www.ti.com/opticalnetwork
Microcontrollers	microcontroller.ti.com	Security	www.ti.com/security
		Telephony	www.ti.com/telephony
		Video & Imaging	www.ti.com/video
		Wireless	www.ti.com/wireless

Mailing Address: Texas Instruments
Post Office Box 655303 Dallas, Texas 75265

Copyright © 2003, Texas Instruments Incorporated