

Rafael A. Mena
Systems Architect
Texas Instruments

Tyler Witt
Applications Engineer
Texas Instruments

Prajakta Desai
Product Marketing Engineer
Texas Instruments

Introduction

Many industrial automation and process control solutions require precision sensing of multiple process or control variables. Such variables include temperature, load, force, light intensity, motion, position and voltage. TI's newest family of embedded microcontrollers (MCUs), the MSP430i20xx series, provides for up to 4 integrated 24-bit sigma-delta analog-to-digital converters (ADC) with low per-channel power conversion. The sensor output can be sensed directly via a differential input programmable gain amplifier (PGA) prior to the 24-bit ADC. The PGA provides for a high impedance buffer with unity gain or a software-defined gain of up to 16. In line-powered solutions, used commonly in industrial applications, the multi-channel ADC solution provides for simultaneous monitoring of multiple sensors without exceeding system current thresholds defined by the communication loop. It also enables extended battery life in multi-channel battery-powered sensing applications. This paper will review line-powered solutions configured as a 2-wire transmitter, where the communication loop provides power to the system and as a 3-wire and 4-wire transmitter, where power to the system is independent to the communication loop. The MSP430i20xx family of MCUs provides support for these configurations up to operating free-air temperatures of 105 degrees Celsius.

Multi-sensor field transmitter solutions

Industrial transmitter design

The vast majority of industrial automation and sensor solutions still rely on line-powered solutions [1]. Ease of use, reliable transfer of data over long distances, low susceptibility to noise and low cost make this solution ideal for robust industrial solutions. These solutions provide both power to the system and the communication path between the sensor and the gateway. In this case, the system consists of a voltage-controlled current source modulating the loop current in response to sensor signal outputs. The modulated current typically runs from 4mA to 20mA where the minimum range value of the sensor is represented by 4mA and the maximum range value of the sensor output is represented by 20mA. The linear region between these two end points represents intermediate values for the sensor output.

Figure 1 shows a typical configuration of the voltage-controlled current source. The current through the loop is governed by the current divider circuit defined by R6 and R7 and the reference current through R5. Given the communication loop is based on a current value, the accuracy of the signal is not impacted by the voltage drop in the interconnecting wire. Thus, the distance between the transmitter and the receiver can be up to thousands of meters [1]. In this case, the transmitter does not source the current. Current is drawn by an external voltage source connected to its output terminals. This translates to an additional advantage in that the communication loop provides power to the transmitter itself. Given that the minimum allowed measurement value is defined by the 4mA threshold, the entire system current for the transmitter solution needs to be below this cut-off point, typically below 3.5mA. Thus, margin is available for alarm low readings.

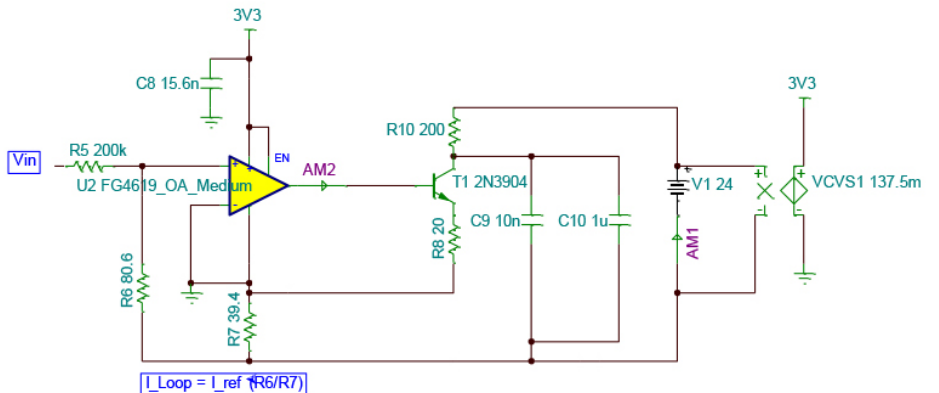

Figure 1. Schematic of a voltage-controlled current source

A current loop transmitter is comprised of a sensor, sensor interface, microcontroller and a voltage-controlled current source (or current DAC). A block diagram of a typical transmitter is shown in Figure 2. In the case of the MSP430i20xx family of MCUs, the sensor signal can be sensed directly through the differential inputs of the 24-bit sigma-delta ADCs. Biasing of the current driver for the voltage-controlled current source can be achieved through a pulse width modulated (PWM) signal with the appropriate duty cycle and filtering requirements. The 16-bit timer module can be used to make an adjustable PWM signal with a theoretical accuracy of up to 16 bits [2]. This output signal of varying duty cycle can then be routed through a low pass filter designed to only allow a DC voltage source from its output. This filter is designed in a way so the cutoff frequency is lower than the PWM frequency, thus ensuring the monotonicity of the voltage output.

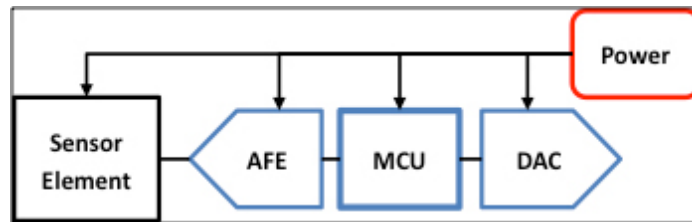

Figure 2: Block diagram of a current loop transmitter

Current loop solutions

As mentioned earlier, the transmitter can either be powered through the communication loop via a 2-wire implementation or through a separate powered line not associated directly with the 4-20mA current loop, typically classified as a 3-wire or 4-wire solution. In both cases, a low-dropout (LDO) regulator steps down the current loop supply voltage to power the transmitter. Figure 3 offers a view of both a 2-wire and 3-wire solution. In the 2-wire solution it is important to maintain a current threshold below the 3.5mA in order to ensure the minimum transmitted measurement value of 4mA is achieved with margin for alarm low levels.

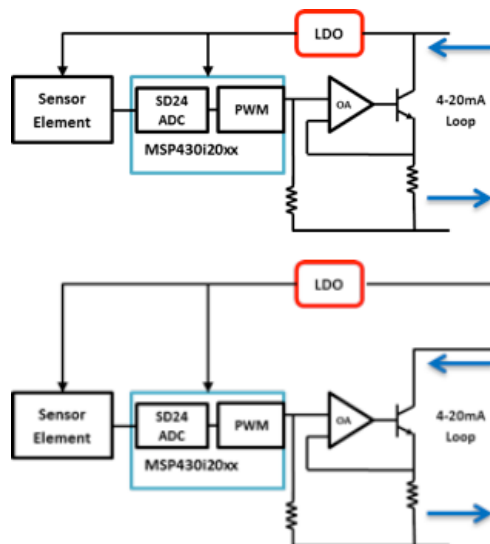

Figure 3: Block diagrams of 2-wire and 3-wire current loops

Sensor interface

A number of advanced industrial market segments use high-performance acquisition systems with multiple channels to manage information on a near real-time basis from accurate industrial sensors. Typical examples include uninterruptible power supplies, industrial power meters/monitors, vibration and waveform analysis, instrumentation and control systems and data acquisition systems that measure such real-world parameters as temperature, pressure, light intensity, fluid flow and force. The differential input of the onboard PGA interfaced directly to the 24-bit sigma-delta ADC enables direct, high-precision sensing of the sensor signal. Additionally, the converters are based on second-order sigma-delta modulators and digital decimation filters. The decimation filters are SINC3 comb-type filters with a selectable oversampling ratio of up to 256 [2]. There are up to four independent 24-bit sigma-delta ADCs in MSP430i20xx MCUs. This allows up to four sensor interfaces to enable simultaneous sampling of multiple industrial automation or process parameters. Each of the channels consumes an average of only 200 μ A during conversion [3]. In comparison, other solutions are typically between 0.5mA to 1.0mA per channel. This low per-channel current flow on MSP430i20xx MCUs provides for simultaneous sensor sampling even under the stringent threshold requirements of a 2-wire current loop architecture.

Table 1 provides a comparison of the AC and DC conversion resolution of the 4-channel, 24-bit SD24 module on the MSP430i20xx family of MCUs. As is shown, the DC performance of the MSP430i20xx SD24 exceeds 16 effective bits across a majority of the PGA gain settings. This metric is sufficient for more than 0.5 μ A accuracy in a 4-20 mA current loop solution. Additional test data is provided in Figure 3.

Parameter	PGA Gain	Vcc	Typ.	Unit
SINAD*	1	3V	89	dB
	2		89	
	4		87	
	8		83	
	16		77	
DC ENOB (internal resistor)	1	3V	16.71	bits
	2		16.58	
	4		16.71	
	8		16.09	
	16		15.03	
DC ENOB (external resistor)	1	3V	16.07	bits
	2		16.07	
	4		16.00	
	8		15.64	
	16		15.14	

Table 1: Comparison of the AC and DC conversion resolution of the 4-channel, 24-bit SD24 module on MSP430i20xx devices. * As specified in the MSP430i20xx Data Sheet.

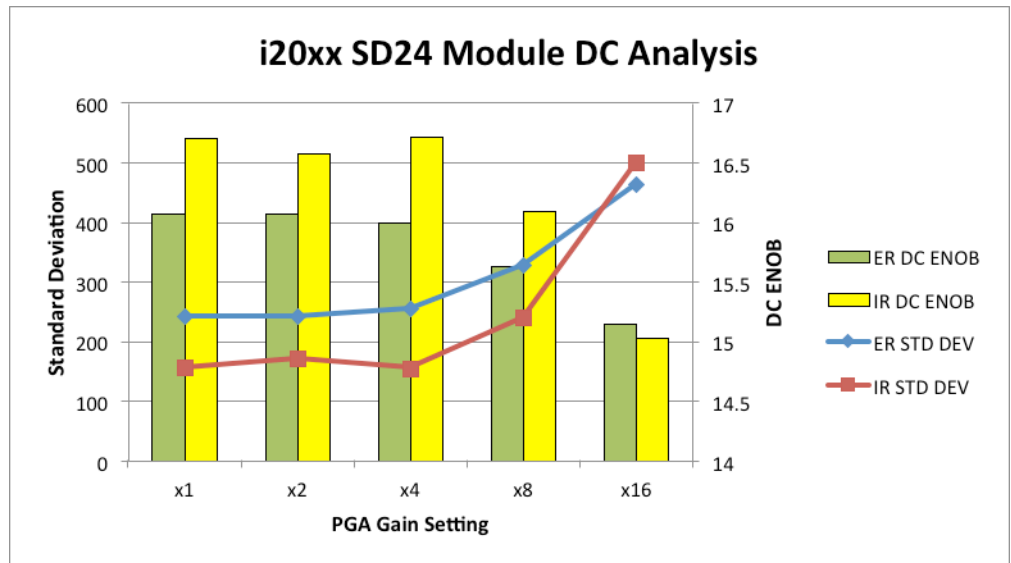

Figure 3. DC analysis of MSP430i20xx SD24 performance

The DC analysis data shown in Figure 3 and presented in Table 1 was acquired by a standard method of shorting the differential input of the SD24 and finding the standard deviation of a large sum of data. More explicitly, a code example was written to store 256 samples of 24-bit values in a block of RAM, which was then downloaded through TI's Code Composer Studio™ IDE to a text file. To calculate the ENOB for AC data, a simple formula incorporating the SINAD is used. This formula states that $ENOB = (SINAD - 1.76dB)/6.02dB$. For DC data, the standard deviation of the data is taken, from which ENOB can be calculated as $ENOB = N - \log_2(\sigma)$. In this equation, N stands for the number of bits the converter provides, while σ is the standard deviation of the data [4].

Conclusion

The MSP430i20xx family of MCUs with up to four 24-bit sigma-delta ADCs is ideally suited for high-precision industrial sensing applications. The low per-channel ADC power efficiency enables simultaneous sampling of multiple high-precision sensor outputs without exceeding current threshold levels defined by many 2-wire industrial current loop solutions. It's also an ideal fit for many multi-sensor battery-powered applications.

References

1. Jefferson Daniel de Barros Sodera, Julio Cesar Saldana, Cesar Giacomini Pentead, Hugo Daniel Hernandez, Raul Acosta, Fernando Chavez Porras, Marcos A. Valerio, Angelica dos Anjos and Paulo H. Trevisan, "On-chip 4to20mA reconfigurable current loop transmitter for smart sensor applications", Integrated Circuits and Systems Design (SBCCI), 2015, August 30, 2012
2. MSP430i20xx Family User's Guide (SLAU335)
3. MSP430i20xx Mixed Signal Microcontroller Data Sheet (SLAS887)
4. B. Baker, ENOB Video Tutorial. [Video Training]. Dallas, TX : Texas Instruments, 2011. <http://focus.ti.com/docs/training/catalog/events/event.jhtml?sku=WEB408001>

Important Notice: The products and services of Texas Instruments Incorporated and its subsidiaries described herein are sold subject to TI's standard terms and conditions of sale. Customers are advised to obtain the most current and complete information about TI products and services before placing orders. TI assumes no liability for applications assistance, customer's applications or product designs, software performance, or infringement of patents. The publication of information regarding any other company's products or services does not constitute TI's approval, warranty or endorsement thereof.

The platform bar and MSP430 are trademarks of Texas Instruments.
All other trademarks are the property of their respective owners.

E010208

IMPORTANT NOTICE

Texas Instruments Incorporated and its subsidiaries (TI) reserve the right to make corrections, enhancements, improvements and other changes to its semiconductor products and services per JESD46, latest issue, and to discontinue any product or service per JESD48, latest issue. Buyers should obtain the latest relevant information before placing orders and should verify that such information is current and complete. All semiconductor products (also referred to herein as "components") are sold subject to TI's terms and conditions of sale supplied at the time of order acknowledgment.

TI warrants performance of its components to the specifications applicable at the time of sale, in accordance with the warranty in TI's terms and conditions of sale of semiconductor products. Testing and other quality control techniques are used to the extent TI deems necessary to support this warranty. Except where mandated by applicable law, testing of all parameters of each component is not necessarily performed.

TI assumes no liability for applications assistance or the design of Buyers' products. Buyers are responsible for their products and applications using TI components. To minimize the risks associated with Buyers' products and applications, Buyers should provide adequate design and operating safeguards.

TI does not warrant or represent that any license, either express or implied, is granted under any patent right, copyright, mask work right, or other intellectual property right relating to any combination, machine, or process in which TI components or services are used. Information published by TI regarding third-party products or services does not constitute a license to use such products or services or a warranty or endorsement thereof. Use of such information may require a license from a third party under the patents or other intellectual property of the third party, or a license from TI under the patents or other intellectual property of TI.

Reproduction of significant portions of TI information in TI data books or data sheets is permissible only if reproduction is without alteration and is accompanied by all associated warranties, conditions, limitations, and notices. TI is not responsible or liable for such altered documentation. Information of third parties may be subject to additional restrictions.

Resale of TI components or services with statements different from or beyond the parameters stated by TI for that component or service voids all express and any implied warranties for the associated TI component or service and is an unfair and deceptive business practice. TI is not responsible or liable for any such statements.

Buyer acknowledges and agrees that it is solely responsible for compliance with all legal, regulatory and safety-related requirements concerning its products, and any use of TI components in its applications, notwithstanding any applications-related information or support that may be provided by TI. Buyer represents and agrees that it has all the necessary expertise to create and implement safeguards which anticipate dangerous consequences of failures, monitor failures and their consequences, lessen the likelihood of failures that might cause harm and take appropriate remedial actions. Buyer will fully indemnify TI and its representatives against any damages arising out of the use of any TI components in safety-critical applications.

In some cases, TI components may be promoted specifically to facilitate safety-related applications. With such components, TI's goal is to help enable customers to design and create their own end-product solutions that meet applicable functional safety standards and requirements. Nonetheless, such components are subject to these terms.

No TI components are authorized for use in FDA Class III (or similar life-critical medical equipment) unless authorized officers of the parties have executed a special agreement specifically governing such use.

Only those TI components which TI has specifically designated as military grade or "enhanced plastic" are designed and intended for use in military/aerospace applications or environments. Buyer acknowledges and agrees that any military or aerospace use of TI components which have **not** been so designated is solely at the Buyer's risk, and that Buyer is solely responsible for compliance with all legal and regulatory requirements in connection with such use.

TI has specifically designated certain components as meeting ISO/TS16949 requirements, mainly for automotive use. In any case of use of non-designated products, TI will not be responsible for any failure to meet ISO/TS16949.

Products

Audio	www.ti.com/audio
Amplifiers	amplifier.ti.com
Data Converters	dataconverter.ti.com
DLP® Products	www.dlp.com
DSP	dsp.ti.com
Clocks and Timers	www.ti.com/clocks
Interface	interface.ti.com
Logic	logic.ti.com
Power Mgmt	power.ti.com
Microcontrollers	microcontroller.ti.com
RFID	www.ti-rfid.com
OMAP Applications Processors	www.ti.com/omap
Wireless Connectivity	www.ti.com/wirelessconnectivity

Applications

Automotive and Transportation	www.ti.com/automotive
Communications and Telecom	www.ti.com/communications
Computers and Peripherals	www.ti.com/computers
Consumer Electronics	www.ti.com/consumer-apps
Energy and Lighting	www.ti.com/energy
Industrial	www.ti.com/industrial
Medical	www.ti.com/medical
Security	www.ti.com/security
Space, Avionics and Defense	www.ti.com/space-avionics-defense
Video and Imaging	www.ti.com/video

TI E2E Community

e2e.ti.com