



Document Name	Document No.	Ver	Date	Page
SLM7H12-L Specification	ZJQM-RD-SPC-A0183	0.0	2014/11/03	1/8

EEMB CO., LTD

Polymer Li-ion Battery

Specification

Model: SLM7H12-L

Capacity: 7Ah

Prepared	Checked	Approved

Customer:

Customer Approval (Customer confirmation) :

Customer Approval (Customer confirmation) :		
Signature	Checked	Approved

Address: Room ABCD, 25/F, Block A, Fortune Plaza, NO.7060 Shennan Road Shenzhen, China

Postal code: 518040

Phone: 0086-755-83022275

FAX: 0086-755-83021966

<http://www.eemb.com>

Document Name	Document No.	Ver	Date	Page
SLM7H12-L Specification	ZJQM-RD-SPC-A0183	0.0	2014/11/03	2/8

Catalog

Chapter	Content	Page
0	Catalog.....	2
1	Scope.....	3
2	Battery Cell Basic Characteristics.....	3
2.1	Model.....	3
2.2	Capacity.....	3
2.3	Nominal Voltage.....	3
2.4	Weight.....	3
2.5	Internal Impedance.....	3
2.6	Dimension.....	3
2.7	Charge.....	3
2.8	Discharge.....	3
2.9	Operation Temperature.....	3
2.10	Storage Temperature.....	3
2.11	Storage Relative Humidity.....	3
3	Appearance.....	3
4	Battery Cell Specification.....	3
4.1	Electrical Characteristics.....	3
4.1.1	1C ₅ A rate discharge capacity.....	3
4.1.2	High temp. discharge capacity.....	3
4.1.3	Low temp. discharge capacity.....	4
4.1.4	Cycle Life.....	4
4.1.5	Capacity Retention.....	4
4.2	Acclimatization Characteristics.....	4
4.2.1	High Temp. and High Humidity	4
4.2.2	Vibration	4
4.2.3	Drop.....	4
4.2.4	Low-pressure.....	4
4.3	Safety Characteristics.....	4
4.3.1	Overcharge.....	4
4.3.2	Short-Circuit.....	4
4.3.3	Heating.....	5
4.3.4	Temperature cycle.....	5
5	Spec of PCM.....	5-6
6	Battery Pack's dimension	6
7	Battery Pack's voltage and internal resistance.....	6
8	Warranty.....	6
9	Matters needing attention.....	7-8

Document Name	Document No.	Ver	Date	Page
SLM7H12-L Specification	ZJQM-RD-SPC-A0183	0.0	2014/11/03	3/8

1. Scope

This product specification defines the requirements of the rechargeable polymer lithium-ion battery supplied to the customer by EEMB Co., Ltd.

2. Battery Cell Basic Characteristics

No.	Item	Characteristics	Remark	
2.1	Model	SLM7H12-L		
2.2	Capacity	Nominal Capacity	7000 mAh	0.2C ₅ A
		Minimum	6700 mAh	0.2C ₅ A
2.3	Nominal Voltage	3.7 V		
2.4	Weight	Approx. 420 g		
2.5	Internal Impedance	≤ 130 mΩ	AC 1KHz(50% charge)	
2.6	Dimension	Length	≤ 130 mm	
		Width	≤ 62 mm	
		Thickness	≤ 58 mm	
2.7	Charge	Maximum Current	7000 mA	1C ₅ A (CC&CV)
		Limited Voltage	4.200±0.020 V	
		End-of Current	14 mA	
2.8	Discharge	Maximum Current	14000 mA	2.0C ₅ A
		End Voltage	2.750±0.005 V	
2.9	Operation Temperature	Charge	0 ~ 45 °C	
		Discharge	-20 ~ +60 °C	
2.10	Storage Temperature	1 month	-20 ~ +60 °C	
		3 month	-20 ~ +45 °C	
		12 month	-20 ~ +25 °C	
2.11	Storage Relative Humidity	65±20 %		

3. Appearance

It shall be free from any defects such as remarkable scratches, breaks, cracks, discoloration, leakage, or middle deformation.

Document Name	Document No.	Ver	Date	Page
SLM7H12-L Specification	ZJQM-RD-SPC-A0183	0.0	2014/11/03	4/8

4. Battery Cell Specification

4.1 Electrical Characteristics

No.	Item	Criteria	Test Instructions
5.1.1	1C ₅ A rate discharge capacity	Discharge Time \geq 57min	Full charge at 20 \pm 5 $^{\circ}$ C, rest for 30 min, then discharge at the same temperature with 1.0C ₅ A to 2.75V.
4.1.2	High temp. discharge capacity	Discharge Time \geq 54min	Full charge at 20 \pm 5 $^{\circ}$ C, store at 55 \pm 2 $^{\circ}$ C for 2h, then discharge at the same temperature with 1.0C ₅ A to 2.75V.
4.1.3	Low temp. discharge capacity	Discharge Time \geq 4.25h	Full charge at 20 \pm 5 $^{\circ}$ C, store at -10 $^{\circ}$ C \pm 2 $^{\circ}$ C for 16h~24h, then discharge at the same temperature with 0.2C ₅ A to 3.0V
4.1.4	Cycle Life	\geq 300Cycles	After full charge, rest for 10 min, discharge at constant current of 1.0C ₅ A to 2.75V. Batteries are full charge after 10 minutes. Repeat above steps till retained capacity is 80%
4.1.5	Capacity Retention	Discharge Time \geq 4.5 h	After full charge, store at 20 \pm 5 $^{\circ}$ C for 28 days. Then discharge with 0.2C ₅ A to 2.75V

4.2 Acclimatization Characteristics

No.	Item	Criteria	Test Instructions
4.2.1	High Temp. and High Humidity	No deformation, no rust, no fire or explosion; Discharge time \geq 36min	After full charge, store at 40 $^{\circ}$ C \pm 2 $^{\circ}$ C (90%~95%RH) for 48h. After test, place at 20 $^{\circ}$ C \pm 5 $^{\circ}$ C for 2h and then discharge with 1C ₅ A to end-voltage
4.2.2	Vibration	No damnification, leakage, no fire or explosion; Battery Voltage \geq 3.6V	Batteries are vibrated 30 min in three mutually perpendicular directions with amplitude of 0.38mm (10~30Hz) or 0.19mm (30~55Hz) and the scanning rate of 1oct per min
4.2.3	Drop	No leakage, no fire or explosion; Discharge Time \geq 51 min	Batteries are dropped onto a hard board with the thickness of 18~20mm from 1meter.
4.2.4	Low-pressure	No leakage, no fire or explosion	Put the batteries in a sealed vacuum and reduce internal pressure gradually to lower than 11.6 kpa. Keep for 6h

Document Name	Document No.	Ver	Date	Page
SLM7H12-L Specification	ZJQM-RD-SPC-A0183	0.0	2014/11/03	5/8

4.3 Safety Characteristics

No.	Item	Criteria	Test Instructions
4.3.1	Overcharge	No fire or explosion	Charged the cells at 3C ₅ A current 20±5°C with a voltage limit of 4.8V and Current close to 0 A
4.3.2	Short-Circuit	No fire or explosion; The maximum Temperature: 150°C	Batteries are short-circuited by connecting the positive and negative terminals for 1h with a resistance load of 0.1Ω
4.3.3	Heating	No fire or explosion	Cell is heated in a circulating air oven at a rate of (5±2)°C per minute to 130°C, and then placed for 30 minutes at 130°C
4.3.4	Temperature cycle	No leakage, no fire or explosion	After full charge , place the battery in the temperature control box of 20±5°C, do the following steps: (1)Put the battery into test chamber of 75°C±2°C and keep for 6h. (2)Lower the temperature to -40±2°C and keep for 6h (3)Temperature conversion time is no longer than 30 min (4)Repeat the above three steps for 10 cycles.

Note: Unless otherwise specified, all tests stated in this specification are conducted at the following conditions: Temp. : 20±5°C; Relative Humidity: 25%~85%.

5. Specification of PCM

The specification shall be applied to Lithium polymer battery protection circuit module manufactured by EEMB CO., LTD.

5.1.0 Basic Specification(T=25°C)

Item	Symbol	Content		Criterion	
Over charge Protection	V _{DET1}	Over charge detection voltage(For reference)		4.25±0.05V/cell	
	tV _{DET1}	Over charge detection delay time		0.5S-1.40S	
	V _{REL1}	Over charge release voltage(For reference)		4.15±0.1V/cell	
Over discharge protection	V _{DET2}	Over discharge detection voltage (For reference)		2.5±0.10V/cell	
	tV _{DET2}	Over discharge detection delay time		50ms-200ms	
	V _{REL2}	Over discharge release voltage(For reference)		3.0±0.1V/cell	
Limited to Max peak value current		Peak value	Constant time	10A	3S
Limited to Max loading current		Constant		7A	
Short protection		Detection condition		Exterior short circuit	
		Release condition		Cut short circuit	
Interior resistance	R _{DS}	Main loop electrify resistance		R _{DS} ≤70mΩ	
Current consumption	I _{DD}	Current consume in normal operation		20μA Type 50μA Max	

Document Name	Document No.	Ver	Date	Page
SLM7H12-L Specification	ZJQM-RD-SPC-A0183	0.0	2014/11/03	6/8

5.2.0 PCM General Circuit Diagram(FYI)

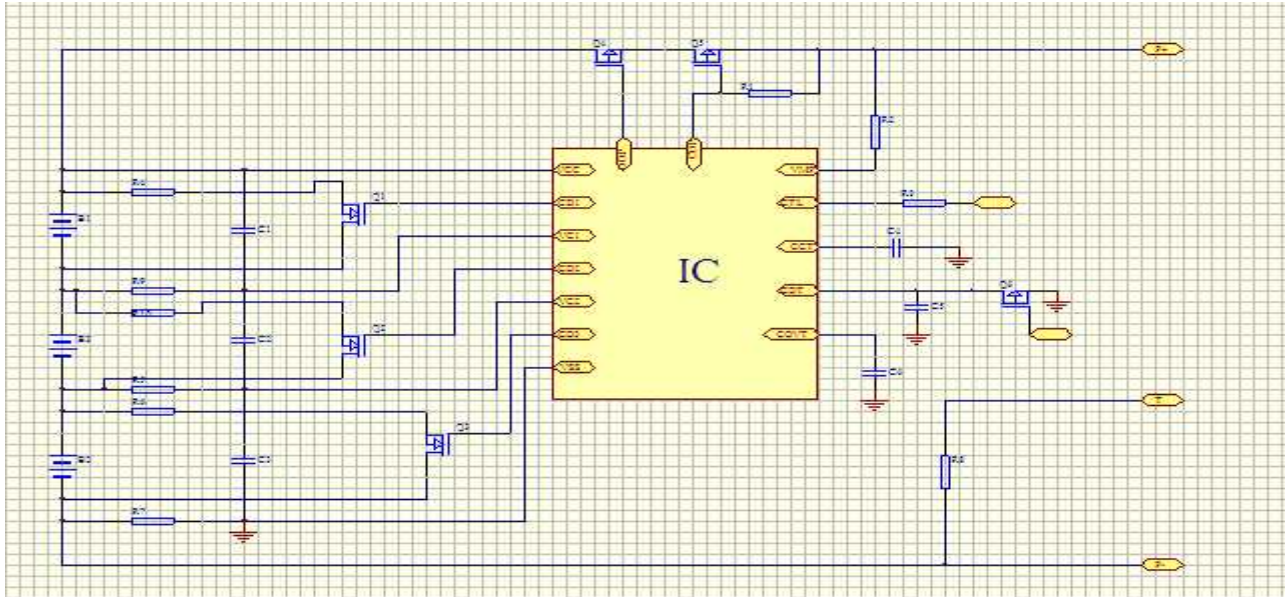

6. Battery Pack's Dimension



Pack's dimension:
L (max) =150mm
H (max) =95mm
W (max) =65mm

7. Battery pack's voltage and internal resistance

Battery Shipment Voltage: 11.49~11.7V

Internal Resistance: $\leq 250m\ \Omega$

8. Warranty

One year warranty after the date of production

Document Name	Document No.	Ver	Date	Page
SLM7H12-L Specification	ZJQM-RD-SPC-A0183	0.0	2014/11/03	7/8

9. Matters needing attention

Strictly observes the following needing attention. EEMB will not be responsible for any accident occurred by handling outside of the precautions in this specification.

! Danger

- Strictly prohibits heat or throw cell into fire.
- Strictly prohibits throw and wet cell in liquid such as water, gasoline or drink etc.
- Strictly prohibits use leave cell close to fire or inside of a car where temperature may be above 60°C. Also do not charge / discharge in such conditions.
- Strictly prohibits put batteries in your pockets or a bag together with metal objects such as necklaces. Hairpins, coins, or screws. Do not store or transportation batteries with such objects.
- Strictly prohibits short circuit the (+) and (-) terminals with other metals.
- Do not place Cell in a device with the (+) and (-) in the wrong way around.
- Strictly prohibits pierce Cell with a sharp object such as a needle.
- Strictly prohibits disassemble or modify the cell.
- Strictly prohibits welding a cell directly.
- Do not use a Cell with serious scar or deformation.
- Thoroughly read the user's manual before use, inaccurate handling of lithium ion rechargeable cell may cause leakage, heat, smoke, an explosion, or fire, capacity decreasing.

! Warning

- Strictly prohibits put cell into a microware oven, dryer, or high-pressure container.
- Strictly prohibits use cell with dry cells and other primary batteries, or new and old battery or batteries of a different package, type, or brand.
- Stop charging the Cell if charging is not completed within the specified time.
- Stop using the Cell if abnormal heat, odor, discoloration, deformation or abnormal condition is detected during use, charge, or storage.
- Keep away from fire immediately when leakage or foul odor is detected.
- If liquid leaks onto your skin or clothes, wash well with fresh water immediately.
- If liquid leaking from the Cell gets into your eyes, do not rub your eyes. Wash them well with clean edible oil and go to see a doctor immediately.

! Caution

- Before using the Cell, be sure to read the user's manual and cautions on handling thoroughly.
- Charging with specific charger according to product specification. Charge with CC/CV method. Strictly prohibits reversed charging. Connect cell reverse will not charge the cell. At the same time, it will reduce the charge-discharge characteristics and safety characteristics, this will lead to product heat and leakage.
- Store batteries out of reach of children so that they are not accidentally swallowed.
- If younger children use the Cell, their guardians should explain the proper handling.
- Before using the Cell, be sure to read the user's manual and cautions on handling thoroughly.
- Batteries have life cycles. If the time that the Cell powers equipment becomes much shorter than usual, the Cell life is at an end. Replace the Cell with a new same one.
- When not using Cell for an extended period, remove it from the equipment and store in a place with low humidity and low temperature.

Document Name	Document No.	Ver	Date	Page
SLM7H12-L Specification	ZJQM-RD-SPC-A0183	0.0	2014/11/03	8/8

- While the Cell pack is charged, used and stored, keep it away from objects or materials with static electric charges.
- If the terminals of the Cell become dirty, wipe with a dry clothe before using the Cell.
- Storage the cells in storage temperature range as the specifications, after full discharged, we suggest that charging to 11.1~12.0V with no using for a long time.
- Do not exceed these ranges of the following temperature ranges:
 - Charge temperature range : 0°C to 45°C;
 - Discharge temperature range : -20°C to 60°C.
 - Store less than 1 month : -20°C - +60°C
 - Store less than 3 months: -20°C - +45°C
 - Store less than 1 year : -20°C - +25°C

! Special Notice

Keep the cells in **50% charged state** during long period storage. We recommend to charge the battery up to 50% of the total capacity every 3 months after receipt of the battery and maintain the voltage 11.1~12.0V. And store the battery in cool and dry place.