

3V AM / FM 1CHIP TUNER IC

TA8127N and TA8127F are the AM / FM 1Chip Tuner ICs, which are designed for Portable Radios and 3V Headphone Radios.

FEATURES

- Built-in
FM F/E, AM / FM IF and FM MPX
- AM Detector Coil and IF Coupling Condenser are not needed.
- Compact Package
TA8127N : Shrink DIP 24 pin (1.78mm pitch)
TA8127F : Mini Flat Package 24 pin
- Operating Supply Voltage Range
 $V_{CC} = 1.8 \sim 7.0V$ ($T_a = 25^\circ C$)

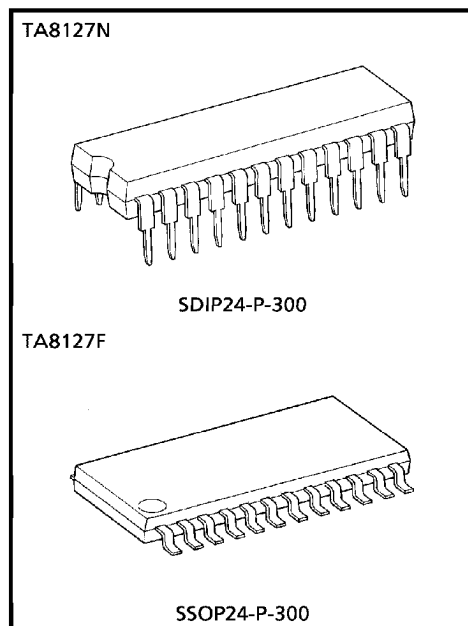

Weight SDIP24-P-300 : 1.2g (Typ.)
SSOP24-P-300 : 0.31g (Typ.)

© The information contained herein is presented only as a guide for the applications of our products. No responsibility is assumed by TOSHIBA CORPORATION for any infringements of intellectual property or other rights of the third parties which may result from its use. No license is granted by implication or otherwise under any intellectual property or other rights of TOSHIBA CORPORATION or others.

© These TOSHIBA products are intended for use in general commercial applications (office equipment, communication equipment, measuring equipment, domestic appliances, etc.). please make sure that you consult with us before you use these TOSHIBA products in equipment which requires extraordinarily high quality and/or reliability, and in equipment which may involve life threatening or critical application, including but not limited to such uses as atomic energy control, airplane or spaceship instrumentation, traffic signals, medical instrumentation, combustion control, all types of safety devices, etc. TOSHIBA cannot accept and hereby disclaims liability for any damage which may occur in case the TOSHIBA products are used in such equipment or applications without prior consultation with TOSHIBA.



TA8127N - 1

1994 - 3 - 8

TOSHIBA CORPORATION

BLOCK DIAGRAM

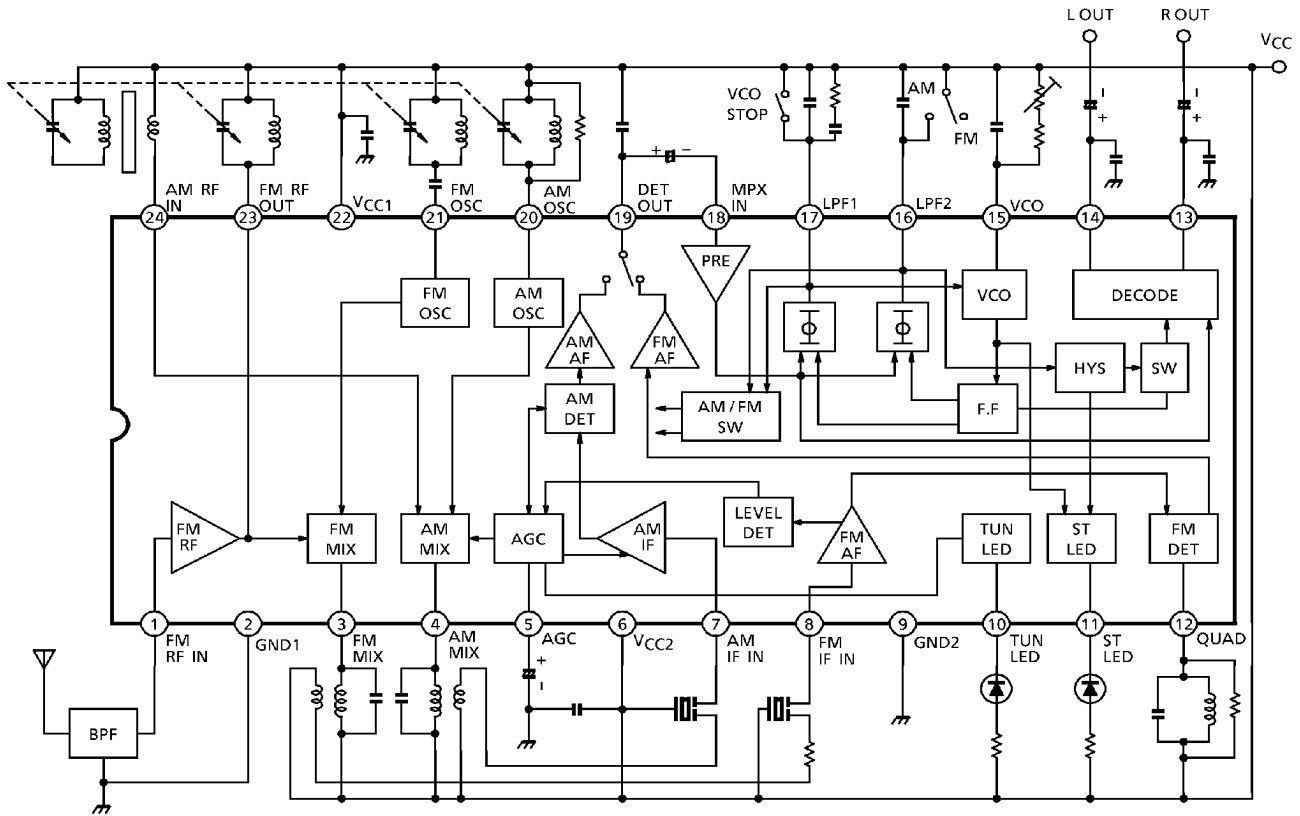

TA8127N - 2
1994 - 3 - 8
TOSHIBA CORPORATION

EXPLANATION OF TERMINALS

PIN NO.	ITEM	INTERNAL CIRCUIT	DC VOLTAGE (V) (AT NO SIGNAL)	
			AM	FM
1	FM-RF IN		0	0.7
2	GND1 (GND for RF Stage)	—	0	0
3	FM MIX		3.0	3.0
4	AM MIX		3.0	3.0
5	AGC (AM AGC)		0	0
6	VCC2 (VCC for IF/MPX Stage)	—	3.0	3.0
7	AM IF IN		3.0	3.0
8	FM IF IN		3.0	3.0

TA8127N - 3
1994 - 3 - 8
TOSHIBA CORPORATION

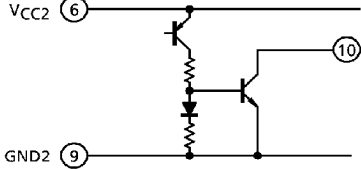
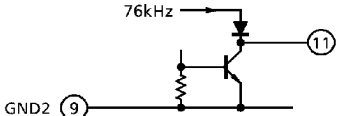
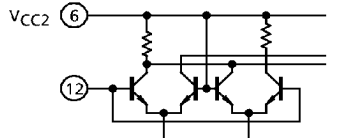
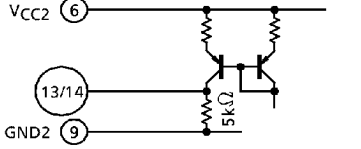
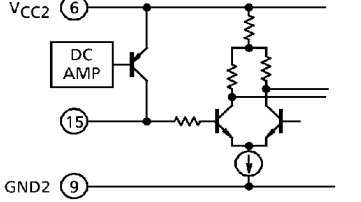
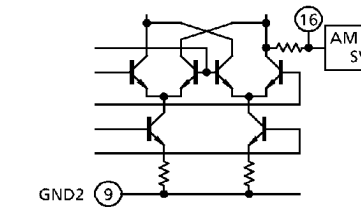
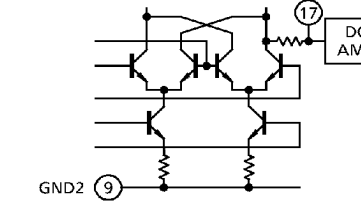
PIN NO.	ITEM	INTERNAL CIRCUIT	DC VOLTAGE (V) (AT NO SIGNAL)	
			AM	FM
9	GND2 (GND for IF / MPX Stage)	—	0	0
10	TUN LED (Tuning LED)		—	—
11	ST LED (Stereo LED)		—	—
12	QUAD (FM QUAD. Detector)		3.0	3.0
13	R-OUT (R-ch Output)		1.0	1.0
14	L-OUT (L-ch Output)			
15	VCO		2.5	2.5 (VCO STOP MODE)
16	LPF2 <ul style="list-style-type: none"> ● LPF Terminal for Synchronous Detector ● Bias Terminal for AM / FM SW Circuit $V_{16} = V_{CC} \rightarrow \text{AM (VCO Stop)}$ $V_{16} = \text{Open} \rightarrow \text{FM}$		3.0	2.2 (VCO STOP MODE) 2.7
17	LPF1 <ul style="list-style-type: none"> ● LPF Terminal for Phase Detector ● VCO Stop Terminal $V_7 = V_{CC} \rightarrow \text{VCO Stop}$		2.7	2.2

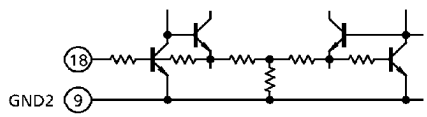
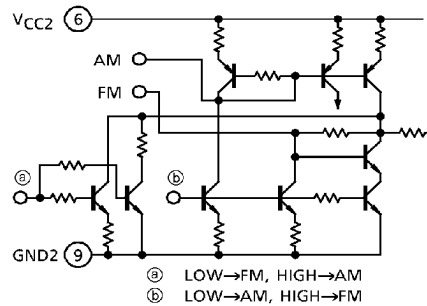
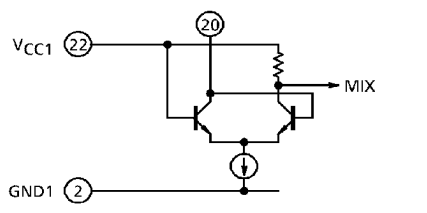
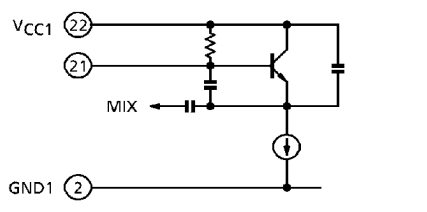
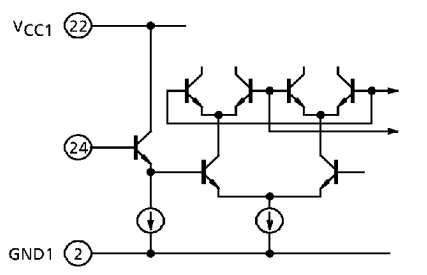
PIN NO.	ITEM	INTERNAL CIRCUIT	DC VOLTAGE (V) (AT NO SIGNAL)	
			AM	FM
18	MPX IN		0.7	0.7
19	DET OUT		1.5	1.2
20	AM OSC		3.0	3.0
21	FM OSC		3.0	3.0
22	VCC1 (VCC for RF Stage)	—	3.0	3.0
23	FM RF OUT	cf. pin①	3.0	3.0
24	AM RF IN		3.0	3.0

TA8127N - 5
1994 - 3 - 8
TOSHIBA CORPORATION

MAXIMUM RATINGS (Ta = 25°C)

CHARACTERISTIC		SYMBOL	RATING	UNIT
Supply Voltage		V _{CC}	8	V
LED Current		I _{LED}	10	mA
LED Voltage		V _{LED}	8	V
Power Dissipation	TA8127N	P _D (Note)	1200	mW
	TA8127F		400	
Operating Temperature		T _{opr}	-25~75	°C
Storage Temperature		T _{stg}	-55~150	°C

Note : Derated above 25°C in the proportion of 9.6mW/°C for TA8127N and of 3.2mW/°C for TA8127F.

TA8127N - 6
1994 - 3 - 8
TOSHIBA CORPORATION

ELECTRICAL CHARACTERISTICS

Unless otherwise specified,

$T_a = 25^\circ\text{C}$, $V_{CC} = 3\text{V}$, F/E : $f = 83\text{MHz}$, $f_m = 1\text{kHz}$

FM IF : $f = 10.7\text{MHz}$, $\Delta f = \pm 22.5\text{kHz}$, $f_m = 1\text{kHz}$

AM : $f = 1\text{MHz}$, $\text{MOD} = 30\%$, $f_m = 1\text{kHz}$

MPX : $f_m = 1\text{kHz}$

CHARACTERISTIC		SYMBOL	TEST CIRCUIT	TEST CONDITION	MIN.	TYP.	MAX.	UNIT
Supply Current		$I_{CC}(\text{FM})$	1	$V_{in} = 0$, FM Mode	—	13.2	20.0	mA
		$I_{CC}(\text{AM})$	1	$V_{in} = 0$, AM Mode	—	8.4	13.5	
F/E	Input Limiting Voltage	$V_{in}(\text{lim.})$	1	-3dB Limiting	—	10.0	—	$\text{dB}\mu\text{V EMF}$
	Local OSC Voltage	V_{OSC}	2	$f_{OSC} = 72.3\text{MHz}$	—	105	—	mV_{rms}
FM IF	Input Limiting Voltage	$V_{in}(\text{lim.})$ IF	1	-3dB Limiting	40	46	53	$\text{dB}\mu\text{V EMF}$
	Recovered Output Voltage	V_{OD}	1	$V_{in} = 80\text{dB}\mu\text{V EMF}$	55	80	110	mV_{rms}
	Signal to Noise Ratio	S/N	1	$V_{in} = 80\text{dB}\mu\text{V EMF}$	—	70	—	dB
	Total Harmonic Distortion	THD	1	$V_{in} = 80\text{dB}\mu\text{V EMF}$	—	0.4	—	%
	AM Rejection Ratio	AMR	1	$V_{in} = 80\text{dB}\mu\text{V EMF}$	—	32	—	dB
	Lamp ON sensitivity	V_L	1	$I_L = 1\text{mA}$	45	51	56	$\text{dB}\mu\text{V EMF}$
AM	Gain	G_V	1	$V_{in} = 26\text{dB}\mu\text{V EMF}$	40	70	110	mV_{rms}
	Recovered Output Voltage	V_{OD}	1	$V_{in} = 60\text{dB}\mu\text{V EMF}$	55	80	110	
	Signal to Noise Ratio	S/N	1	$V_{in} = 60\text{dB}\mu\text{V EMF}$	—	42	—	dB
	Total Harmonic Distortion	THD	1	$V_{in} = 60\text{dB}\mu\text{V EMF}$	—	1.0	—	%
	Lamp ON Sensitivity	V_L	1	$I_L = 1\text{mA}$	20	25	30	$\text{dB}\mu\text{V EMF}$
Pin ¹⁹ Output Resistance		R_{19}	1	FM Mode	—	0.75	—	$\text{k}\Omega$
				AM Mode	—	12.5	—	

TA8127N - 7

1994 - 3 - 8

TOSHIBA CORPORATION

CHARACTERISTIC		SYMBOL	TEST CIRCUIT	TEST CONDITION	MIN.	TYP.	MAX.	UNIT	
MPX	Input Resistance	R_{IN}	—	—	—	24	—	$k\Omega$	
	Output Resistance	R_{OUT}	—	—	—	5	—		
	Max. Composite Signal Input Voltage	V_{in} (max.) STEREO	1	L + R = 90%, P = 10% $f_m = 1kHz$, THD = 3%	—	350	—	mV_{rms}	
	Separation	Sep	1	L + R = $135mV_{rms}$ P = $15mV_{rms}$	$f_m = 100Hz$	—	42	—	dB
					$f_m = 1kHz$	35	42	—	
					$f_m = 10kHz$	—	42	—	
	Total Harmonic Distortion	Monaural	THD (MONAURAL)	1	$V_{in} = 150mV_{rms}$	—	0.2	—	%
		Stereo	THD (STEREO)		L + R = $135mV_{rms}$, P = $15mV_{rms}$	—	0.2	—	
	Voltage Gain		G_V (MPX)	1	$V_{in} = 150mV_{rms}$	-5	-3	-1	dB
	Channel Balance		C.B.	1	$V_{in} = 150mV_{rms}$	-2	0	2	
	Stereo Lamp Sensitivity	ON	$V_L(ON)$	1	Pilot Input	—	8	16	mV_{rms}
		OFF	$V_L(OFF)$		Pilot Input	2	6	—	
Stereo Lamp Hysteresis		V_H	1	To LED turn off from LED turn on	—	2	—	mV_{rms}	
Capture Range		C.R.	1	P = $15mV_{rms}$	—	± 3	—	%	
Signal to Noise Ratio		S/N	1	$V_{in} = 150mV_{rms}$	—	70	—	dB	

TA8127N - 8

1994 - 3 - 8

TOSHIBA CORPORATION

TEST CIRCUIT 1

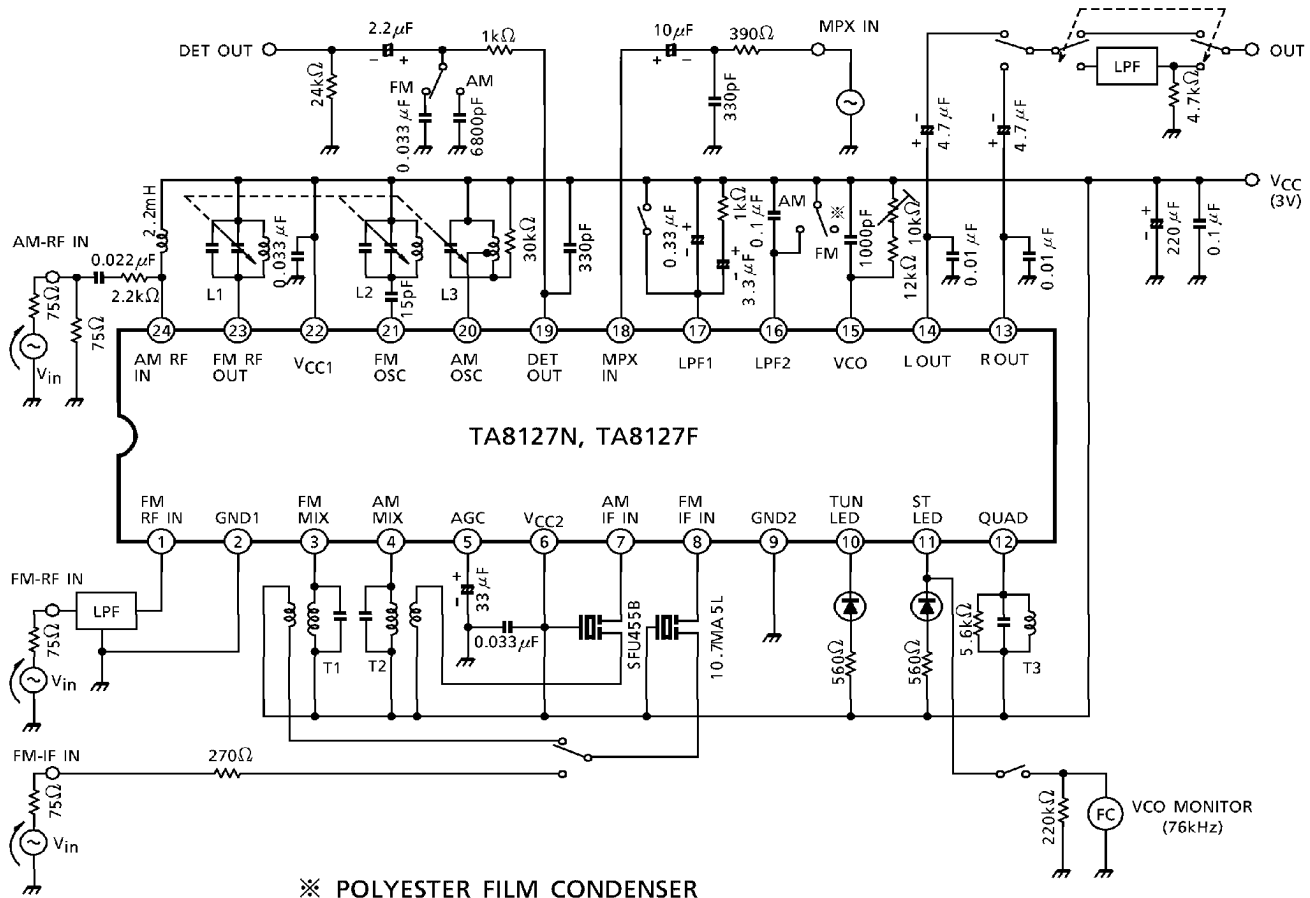

※ POLYESTER FILM CONDENSER

Using other types of condensers, there are some cases that the MPX does not do normal stereo action at high temperature or low temperature.

TA8127N - 9
1994 - 3 - 8
TOSHIBA CORPORATION

TEST CIRCUIT 2

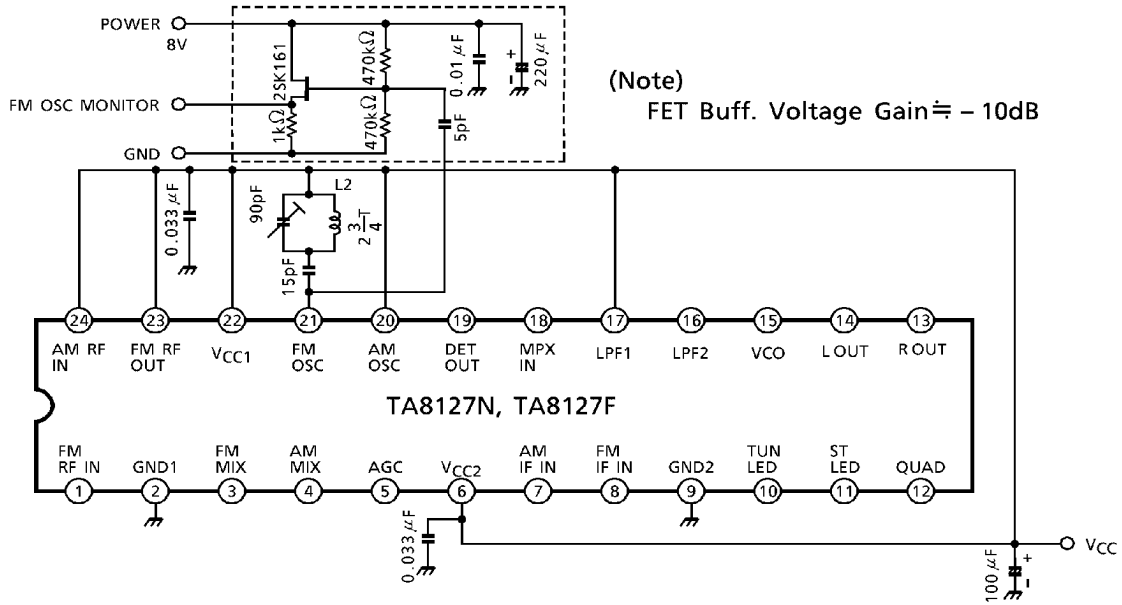

COIL DATA

COIL No.	TEST FREQ. (Hz)	L (μH)	C ₀ (pF)	Q ₀	TURNS					WIRE (mm φ)	REFERENCE
					1-2	2-3	1-3	1-4	4-6		
L ₁ FM RF	100M	—	—	100	—	—	—	2 $\frac{1}{2}$	—	0.5UEW	Ⓢ 53T-037-202
L ₂ FM OSC	100M	—	—	100	—	—	2 $\frac{3}{4}$	—	—	0.5UEW	Ⓢ 0258-244
L ₃ AM OSC	796k	288	—	115	13	73	—	—	—	0.08UEW	Ⓢ 4147-1356-038
T ₁ FM MIX	10.7M	—	75	100	—	—	13	—	2	0.1UEW	Ⓢ 2153-414-041
T ₂ AM MIX	455k	—	180	120	—	—	180	—	15	0.08UEW	Ⓢ 2150-2162-165
T ₃ FM DET	10.7M	—	47	165	—	—	16	—	—	0.09UEW	Ⓢ 2153-4095-122

Ⓢ : SUMIDA ELECTRIC CO., LTD

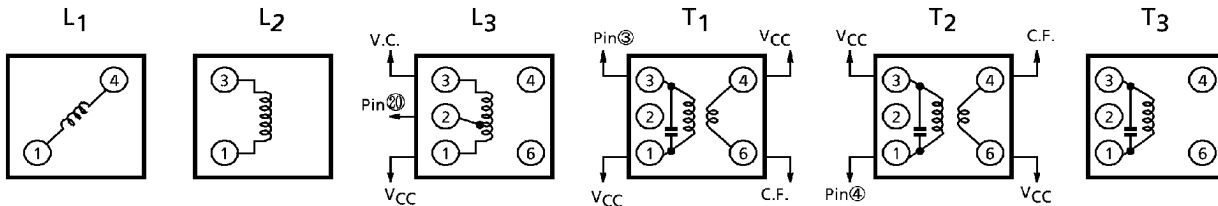

TA8127N - 10
1994 - 3 - 8
TOSHIBA CORPORATION

HINT ON USE OF TA8127N and TA8127F

External Parts of MPX VCO

(1) Temperature characteristic of MPX VCO free-run frequency. The temperature characteristic of MPX VCO is shown in the diagram as below. Select one with a better temperature characteristic (C, R and VR.) in use. We recommend,

- C : POLYESTER FILM
- R, VR. : CARBON FILM

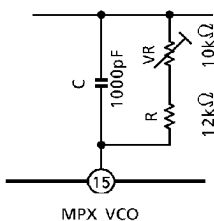
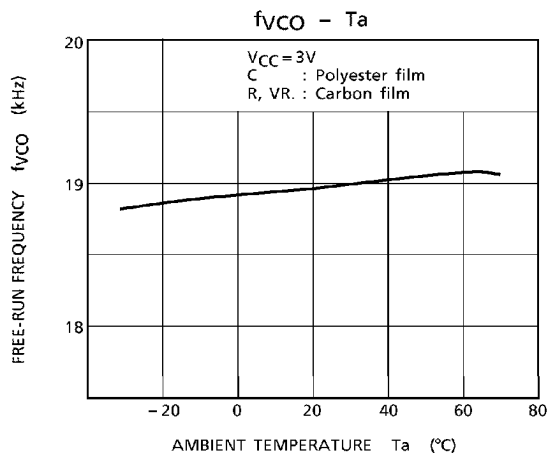

(2) Value of the external parts

We recommend to set up these value as below.

- R = 12kΩ
- VR = 10kΩ
- C = 1000pF

FM (F/E + IF)
VOD, Vno, THD, AMR - Vin

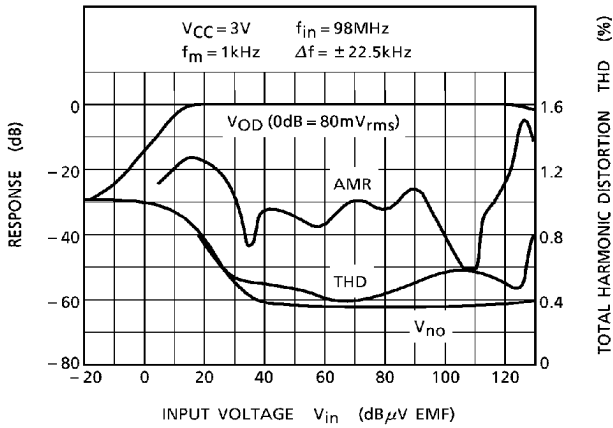

FM (IF)
VOD, Vno, THD, AMR - Vin

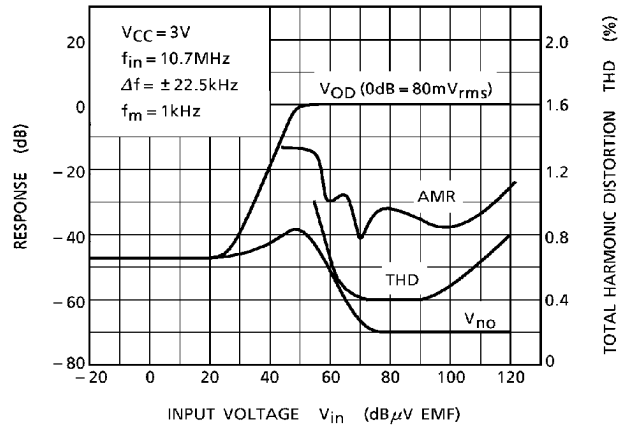

FM (IF)
VOD, THD - Δf

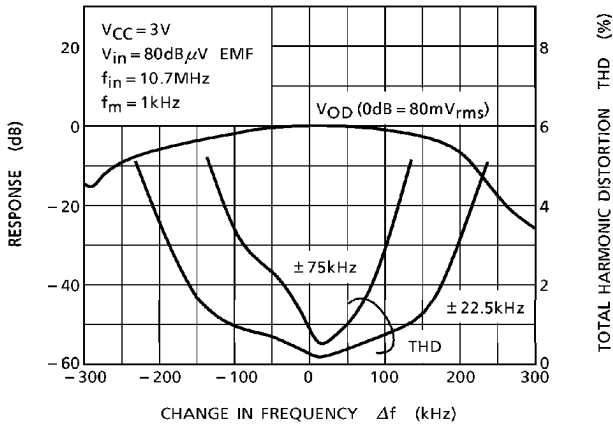

FM (IF)
VOD, Vin (lim.) - VCC

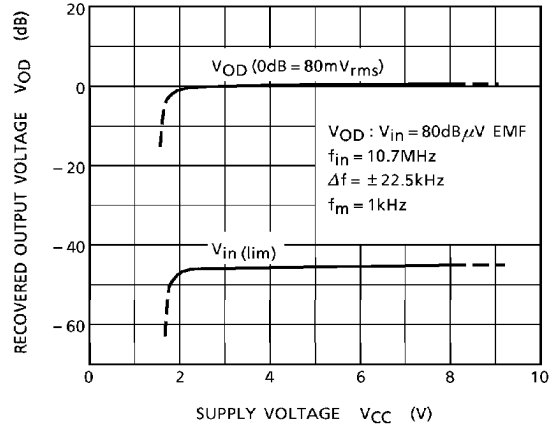

FM (IF)
VOD - Ta

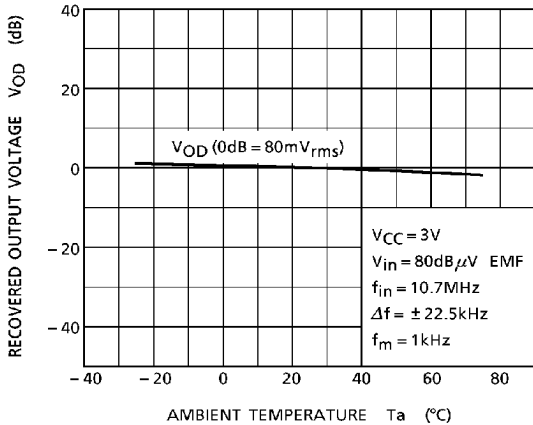

AM
VOD, Vno, THD - Vin

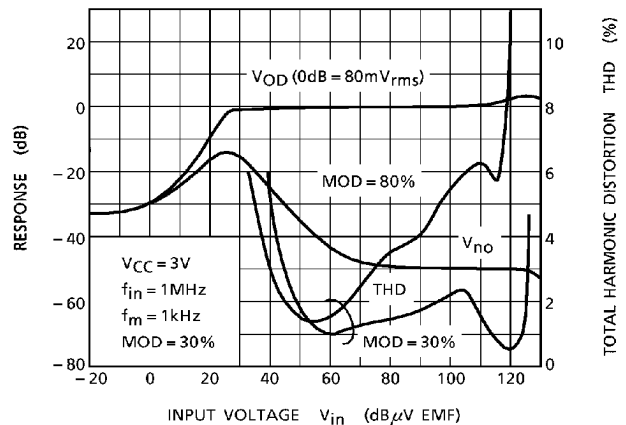

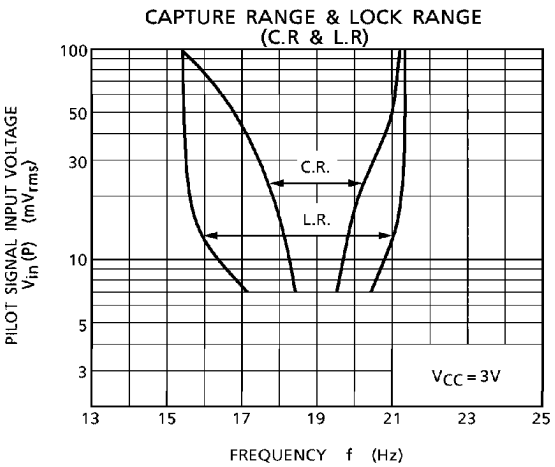
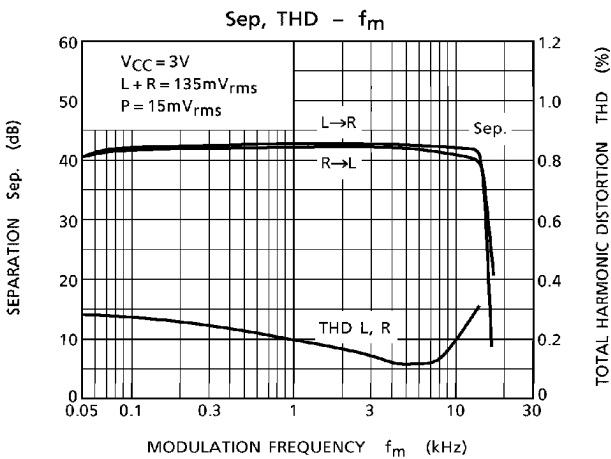
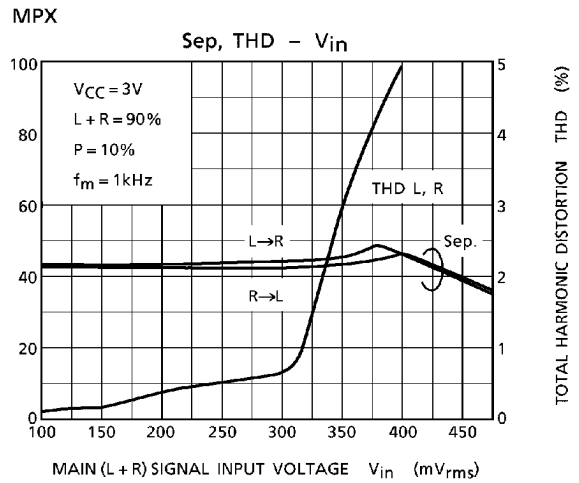
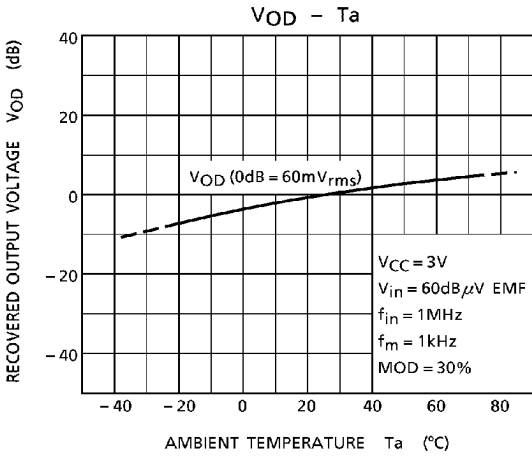
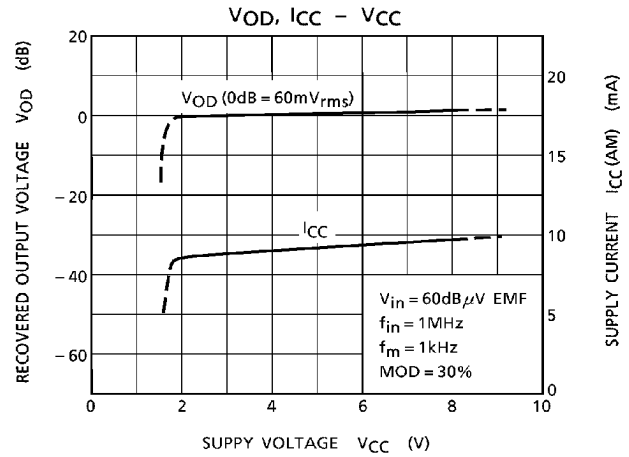
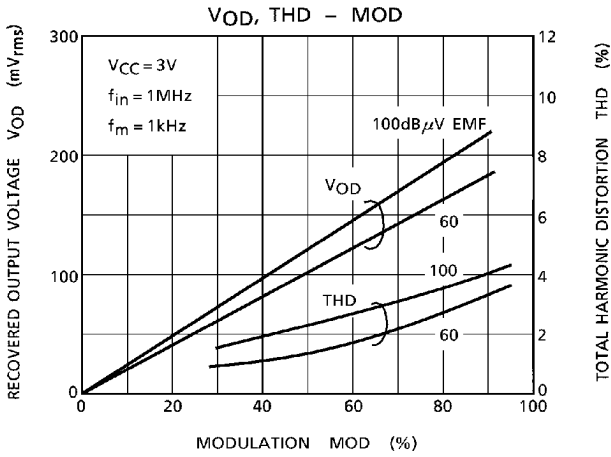

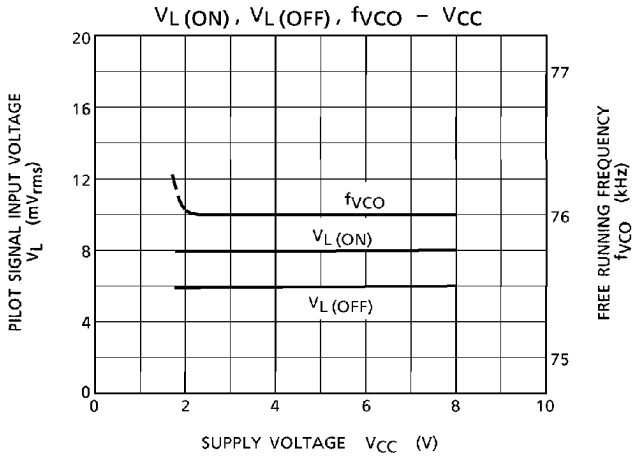
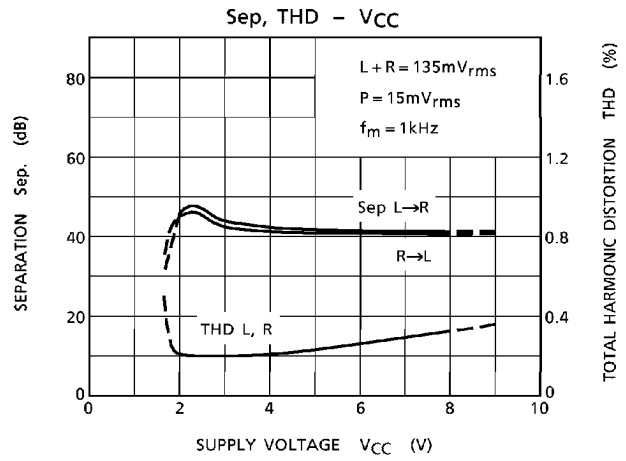
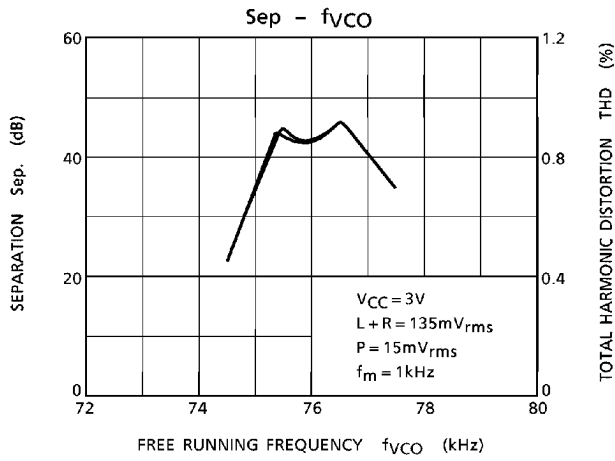

OUTLINE DRAWING
SDIP24-P-300

Unit : mm

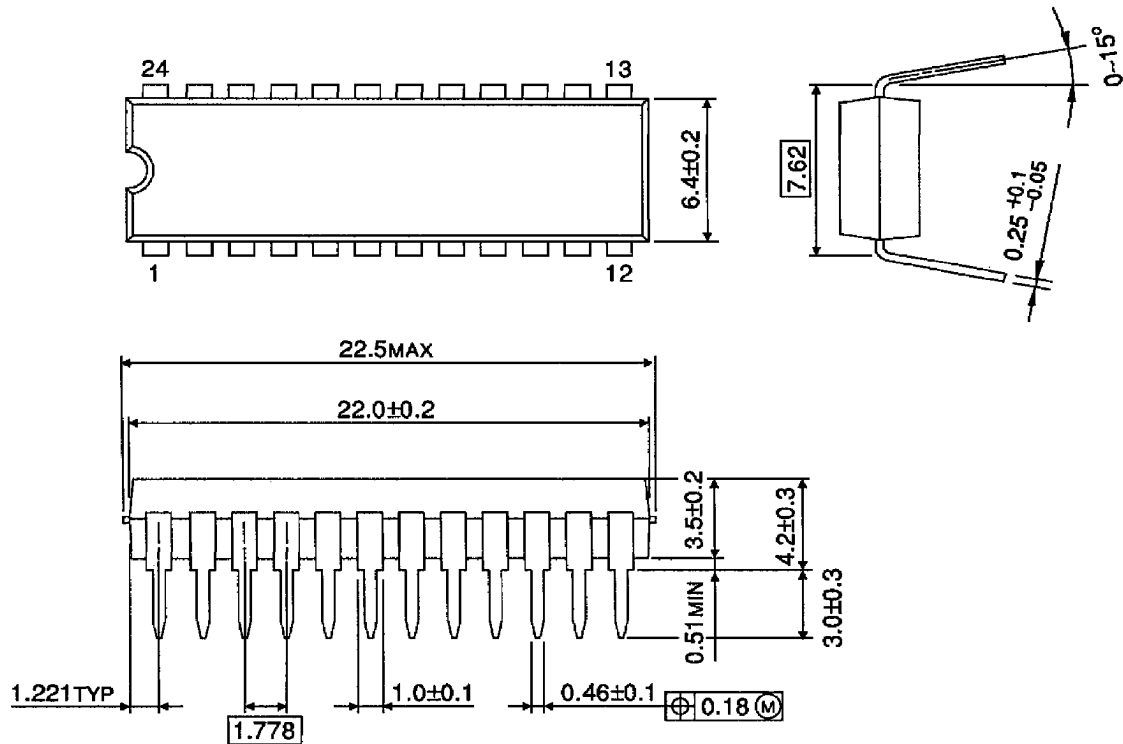

Weight : 1.2g (Typ.)

TA8127N - 15
1994 - 3 - 8
TOSHIBA CORPORATION

OUTLINE DRAWING
SSOP24-P-300

Unit : mm

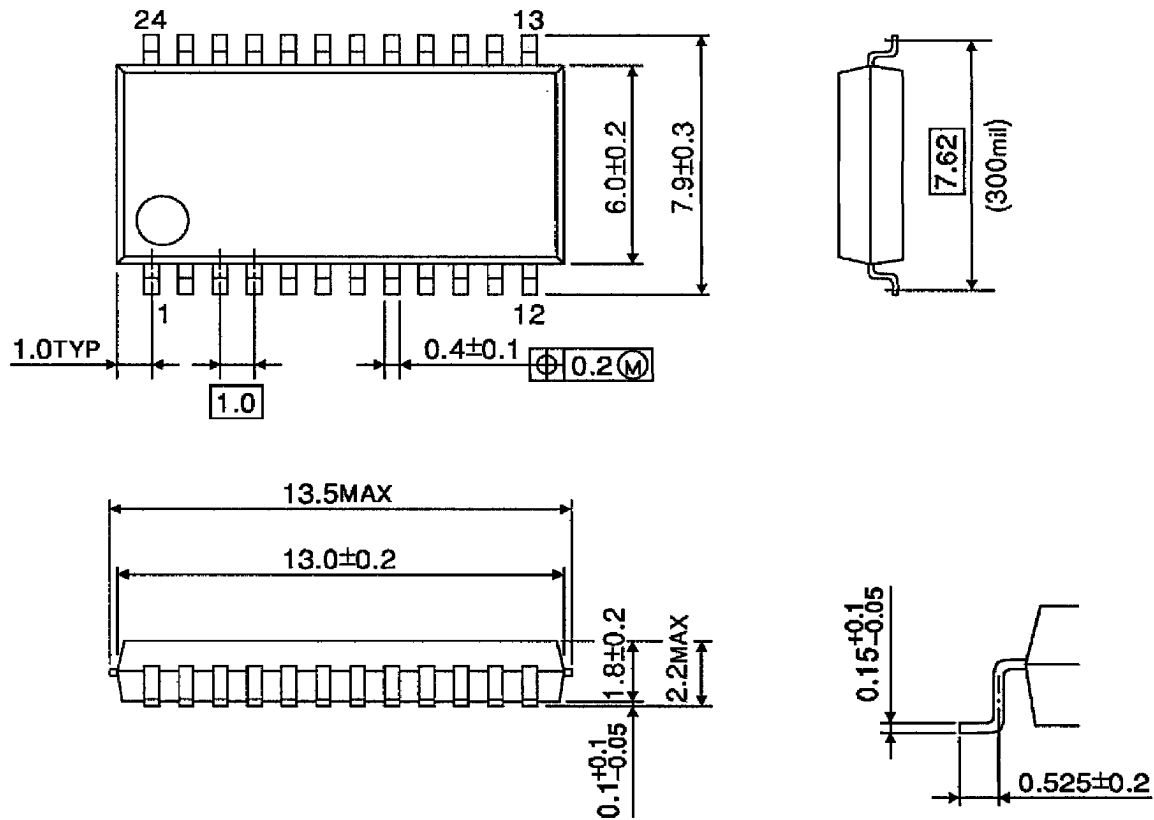

Weight : 0.31g (Typ.)

TA8127N - 16*
1994 - 3 - 8
TOSHIBA CORPORATION