

VIDEO CONTROL COMBINATION CIRCUIT WITH AUTOMATIC CUT-OFF CONTROL

GENERAL DESCRIPTION

The TDA3507 is a monolithic integrated circuit which performs video control functions in a PAL/SECAM decoder.

The required input signals are: luminance and negative colour difference $-(R-Y)$ and $-(B-Y)$, and a 3-level sandcastle pulse for control purposes. Linear RGB signals can be inserted from an external source. RGB output signals are available for driving the video output stages. This circuit provides automatic cut-off control of the picture tube.

The TDA3507 is the same as the TDA3505 but with RGB channel bandwidths of (typical) 16 MHz and an automatic cut-off cycle that ends in line 15.

Features

- Capacitive coupling of the colour difference and luminance input signals with black level clamping in the input stages
- Linear saturation control acting on the colour difference signals
- $(G-Y)$ and RGB matrix
- Linear transmission of inserted signals
- Equal black levels for inserted and matrixed signals
- 3 identical channels for the RGB signals
- Linear contrast and brightness controls, operating on both the inserted and matrixed RGB signals
- Peak beam current limiting input
- Clamping, horizontal and vertical blanking of the three input signals controlled by a 3-level sandcastle pulse
- 3 DC gain controls for the RGB output signals (white point adjustment)
- Emitter-follower outputs for driving the RGB output stages
- Input for automatic cut-off control with compensation for leakage current of the picture tube

PACKAGE OUTLINE

28-lead DIL; plastic (SOT117).

QUICK REFERENCE DATA

parameter	conditions	symbol	min.	typ.	max.	unit
Supply voltage (pin 6)		$V_P = V_{6-24}$	—	12	—	V
Supply current		$I_P = I_6$	—	100	—	mA
Composite video input signal (peak-to-peak value)		$V_{15-24(p-p)}$	—	0,45	—	V
Colour difference input signals (peak-to-peak value)						
—(B—Y)		$V_{18-24(p-p)}$	—	1,33	—	V
—(R—Y)		$V_{17-24(p-p)}$	—	1,05	—	V
Inserted RGB signals (black-to-white value)		$V_{12,13,14-24}$	—	1,0	—	V
Three-level sandcastle pulse		V_{10-24}	—	2,5	—	V
			—	4,5	—	V
			—	8,0	—	V
Control voltage ranges						
brightness		V_{20-24}	1,0	—	3,0	V
contrast		V_{19-24}	2,0	—	4,3	V
saturation		V_{16-24}	2,0	—	4,3	V

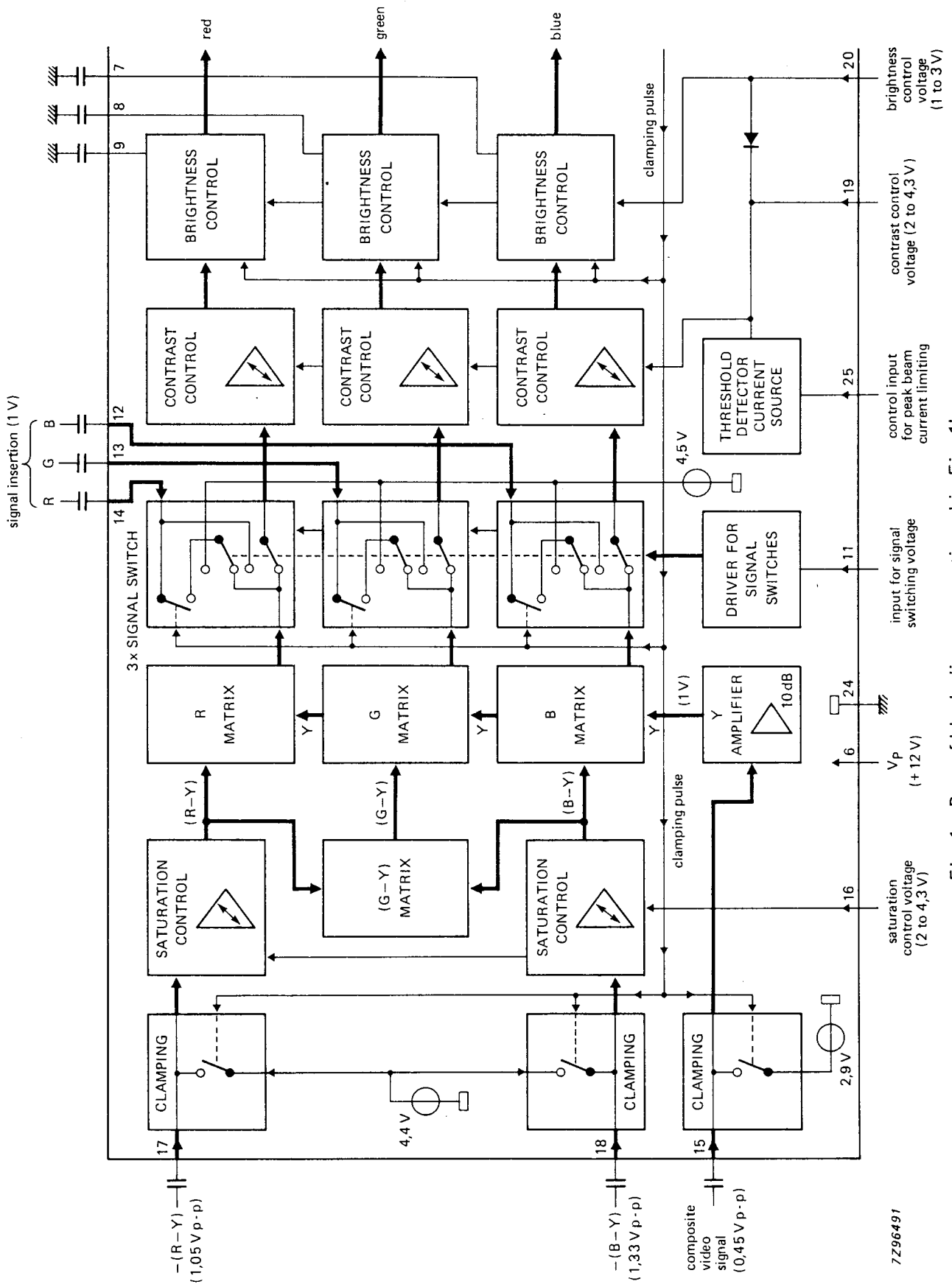
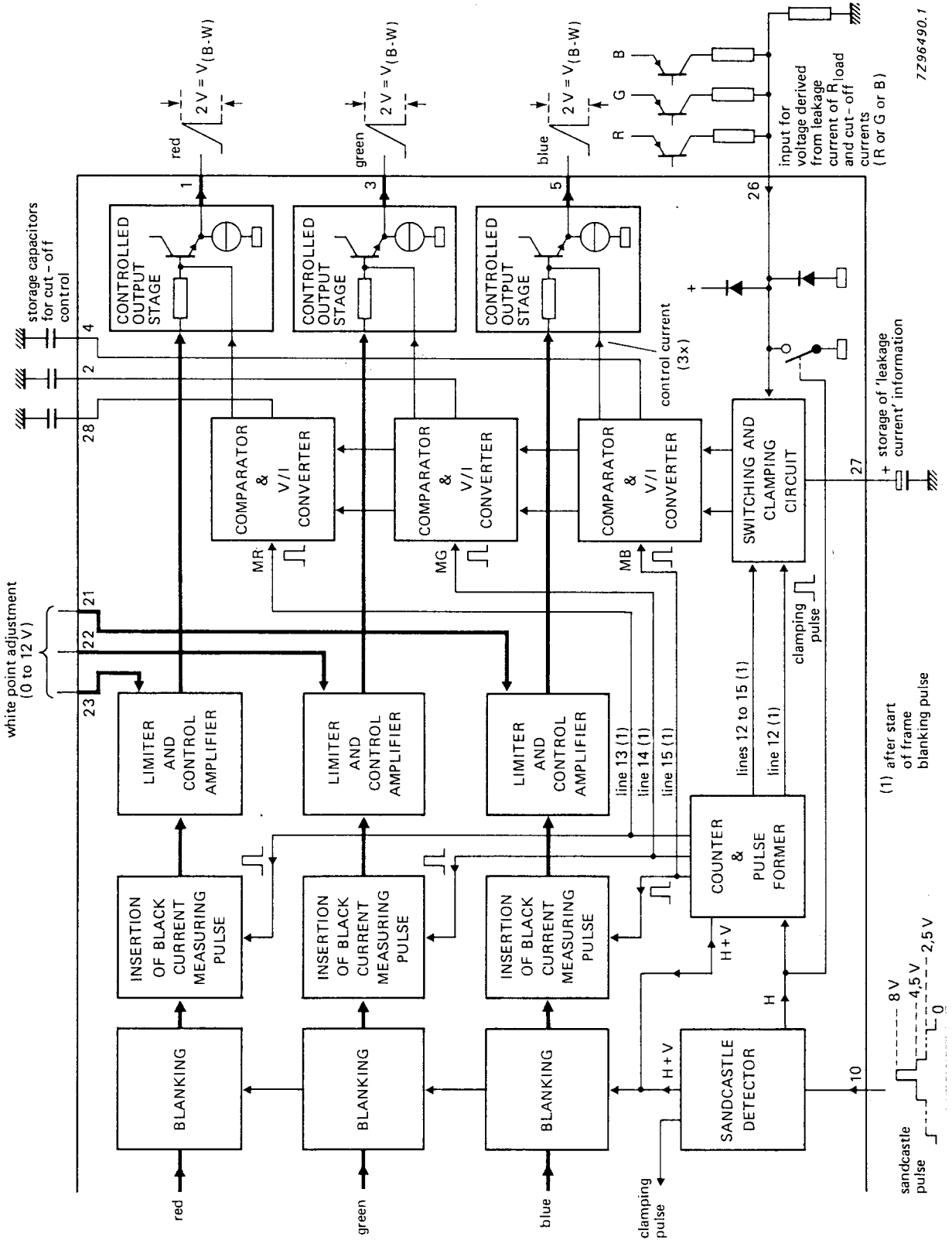

Fig. 1a Part of block diagram, continued in Fig. 1b.

7296491



7Z96490.1

Fig. 1b Part of block diagram, continued from Fig. 1a.

PINNING

pin	description
1	red output
2	green storage capacitor for cut-off control
3	green output
4	blue storage capacitor for cut-off control
5	blue output
6	positive supply voltage (+12 V)
7	blue storage for brightness
8	green storage for brightness
9	red storage for brightness
10	sandcastle pulse input
11	fast switch for RGB inputs
12	blue input (external signal)
13	green input (external signal)
14	red input (external signal)
15	luminance input
16	saturation control input
17	-(R-Y) colour difference input
18	-(B-Y) colour difference input
19	contrast control input
20	brightness control input
21	white point adjustment, blue
22	white point adjustment, green
23	white point adjustment, red
24	ground (0 V)
25	control input for peak beam current limiting
26	automatic cut-off control input
27	storage capacitor for leakage current
28	red storage capacitor for cut-off control

RATINGS

Limiting values in accordance with the Absolute Maximum System (IEC 134)

parameter	symbol	min.	max.	unit
Supply voltage (pin 6)	$V_P = V_{6-24}$	—	13,2	V
Voltage ranges				
at pins 10, 21, 22, 23, 25, 26	V_{n-24}	0	V_P	V
at pin 11	V_{11-24}	-0,5	3,0	V
at pins 16, 19, 20	$V_{16,19,20-24}$	0	0,5 V_P	V
at pins 1, 2, 3, 4, 5, 7, 8, 9, 12, 13, 14, 15, 17, 18, 27, 28	no external DC voltage			
Currents				
at pins 1, 3, 5	- $I_{1,3,5}$	—	3	mA
at pin 19	I_{19}	—	10	mA
at pin 20	I_{20}	—	5	mA
at pin 25	- I_{25}	—	5	mA
Total power dissipation	P_{tot}	—	1,7	W
Storage temperature range	T_{stg}	-25	+150	°C
Operating ambient temperature range	T_{amb}	0	+70	°C

CHARACTERISTICS

$V_P = V_{6-24} = 12,0 \text{ V}$; $V_{12,13,14(p-p)} = 1,0 \text{ V}$; $V_{15-24(p-p)} = 0,45 \text{ V}$; $V_{17-24(p-p)} = 1,05 \text{ V}$;
 $V_{18-24(p-p)} = 1,33 \text{ V}$; $T_{amb} = 25 \text{ }^\circ\text{C}$; measured in Fig. 2; nominal settings of brightness, contrast,
 saturation and white point adjustment; all voltages are referred to pin 24; unless otherwise specified

parameter	conditions	symbol	min.	typ.	max.	unit
Supply (pin 6)						
Supply voltage		$V_P = V_6$	10,8	12,0	13,2	V
Supply current		I_P	—	100	130*	mA
Colour difference inputs (pins 17, 18)						
—(R—Y) input signal (pin 17) (peak-to-peak value)	for saturated colour bar with 75% of maximum amplitude	$V_{17(p-p)}$	—	1,05	1,48	V
—(B—Y) input signal (pin 18) (peak-to-peak value)	for saturated colour bar with 75% of maximum amplitude	$V_{18(p-p)}$	—	1,33	1,88	V
Input current during scanning		$I_{17,18}$	—	—	1,0	μA
Input resistance		$R_{17,18-24}$	1,0	—	—	$\text{M}\Omega$
Internal DC voltage due to clamping	note 1	$V_{17,18}$	3,8	4,4	4,8	V
Saturation control (pin 16)						
Control voltage for maximum saturation	note 1	V_{16}	4,0	4,2	4,4	V
Control voltage for nominal saturation	6 dB below max. note 1	V_{16}	2,9	3,1	3,3	V
Control voltage for —26 dB saturation referred to maximum	note 1	V_{16}	1,9	2,1	2,3	V
Minimum saturation	$V_{16} = 1,8 \text{ V}$	d	46	50	—	dB
Input current		I_{16}	—	—	20	μA
(G—Y) matrix						
Matrixed according to the equation $V_{(G-Y)} = -0,51 V_{(R-Y)} - 0,19 V_{(B-Y)}$						
Luminance input (pin 15)						
Composite video input signal (peak-to-peak value)		$V_{15(p-p)}$	—	450	630	mV
Input resistance		R_{15-24}	100	—	—	$\text{k}\Omega$
Input capacitance		C_{15-24}	—	—	5	pF

* < 115 mA after warm-up

parameter	conditions	symbol	min.	typ.	max.	unit
Luminance input (continued)						
Input current during scanning		I_{15}	—	—	1	μA
Linearity	nominal settings	m	0,85	—	—	
Internal DC voltage due to clamping	note 1	V_{15}	2,5	2,9	3,3	V
RGB channels						
<i>Signal switching input (pin 11)</i>						
Normal state; no insertion		V_{11}	0	—	0,4	V
Level for insertion-on		V_{11}	0,9	—	3,0	V
Input capacitance		C_{11-24}	—	—	10	pF
Input current	$V_{11} = 0 \text{ to } 3 \text{ V}$	I_{11}	−100	—	+450	μA
<i>Signal insertion (pins 12, 13, 14)</i>						
External RGB input signals (black-to-white value)		$V_{12,13,14}$	—	1,0	1,4	V
Input current during scanning		$I_{12,13,14}$	—	—	1,0	μA
Internal DC voltage due to clamping	notes 1, 2	$V_{12,13,14}$	4,0	4,5	5,0	V
Contrast control (pin 19)						
Control voltage for maximum contrast	note 1	V_{19}	4,0	4,2	4,4	V
Control voltage for nominal contrast	3 dB below max.	V_{19}	3,4	3,6	3,8	V
Control voltage for −10 dB below max.		V_{19}	2,6	2,8	3,0	V
Minimum contrast referred to max.	$V_{19} = 2 \text{ V}$	d	18	21	29	dB
Input current	$V_{25} > 6 \text{ V}$	I_{19}	—	—	2	μA
Difference between RGB channels	contrast −10 dB below max.		—	—	0,6	dB
Peak beam current limiting (pin 25)						
Internal DC bias voltage	note 1	V_{25}	5,3	5,5	5,7	V
Input resistance		R_{25-24}	—	10	—	$\text{k}\Omega$
Input current at contrast control input	$V_{25} = 4,5 \text{ V}$	I_{19}	10	20	34	mA

CHARACTERISTICS (continued)

parameter	conditions	symbol	min.	typ.	max.	unit
Brightness control (pin 20)	note 1					
Control voltage range		V_{20}	1	—	3	V
Input current		$-I_{20}$	—	—	10	μA
Change of black level in the control range related to the luminance signal (black/white)	$\Delta V_{20} = 1 \text{ V}$		—	± 50	—	%
Tracking			95	—	—	%
Internal signal limiting (RGB)						
Signal limiting referred to nominal luminance and nominal black level						
black			—	—25	—	%
white			115	120	125	%
White point adjustment (pins 21, 22, 23)	note 1					
AC voltage gain	note 3					
$V_{21,22,23} = 5,5 \text{ V}$		G_V	—	100	—	%
$V_{21,22,23} = 0 \text{ V}$		G_V	—35	—40	—	%
$V_{21,22,23} = 12 \text{ V}$		G_V	+35	+40	—	%
Input resistance		$R_{21,22,23-24}$	—	20	—	$\text{k}\Omega$
RGB outputs (emitter follower) (pins 1, 3, 5)						
Output voltage; black-to-white positive		$V_{1,3,5}$	1,5	2,0	2,5	V
Black level without automatic cut-off control	note 1; $V_{28,2,4} = 10 \text{ V}$	$V_{1,3,5}$	6,1	6,9	7,7	V
Difference in black level between RGB channels due to variation of contrast control		$\Delta V_{1,3,5}$	—	—	10	mV
Cut-off control range	note 1	$V_{1,3,5}$	4,0	4,6	—	V
Internal current source		$I_{1,3,5}$	2,0	3,0	—	mA

parameter	conditions	symbol	min.	typ.	max.	unit
Automatic cut-off control (pin 26)	notes 1,4					
Input voltage range		V ₂₆	0	—	6,5	V
Voltage difference between cut-off current measurement (note 5) and leakage current measurement (note 6)		V ₂₆	0,5	0,64	0,72	V
<i>Input pin 26 switches to ground during horizontal flyback</i>						
Gain data	at nominal brightness, contrast, saturation and white point settings					
Voltage gain with respect to luminance input (pin 15)		G _{1,3,5-15}	14	16	18	dB
Frequency response of luminance path	0 to 5 MHz	d _{1,3,5-15}	—	—	3	dB
Voltage gain with respect to colour difference inputs (pins 17 and 18)		G ₅₋₁₈ G ₁₋₁₇	3	6	9	dB
Frequency response of colour difference paths	0 to 2 MHz	d ₅₋₁₈ d ₁₋₁₇	—	—	3	dB
Voltage gain with respect to inserted signals		G ₁₋₁₄ G ₃₋₁₃ G ₅₋₁₂	4	6	8	dB
Frequency response of inserted signal paths	0 to 16 MHz	d ₁₋₁₄ d ₃₋₁₃ d ₅₋₁₂	—	3	—	dB
Frequency response of inserted signal paths	0 to 13 MHz	d ₁₋₁₄ d ₃₋₁₃ d ₅₋₁₂	—	—	3	dB
Rise and fall times of RGB output signals (pins 1, 3, 5)		t _r ,t _f	—	40	—	ns
Difference in transit times between R, G and B channels		Δt _{1,3,5}	—	0	15	ns

CHARACTERISTICS (continued)

parameter	conditions	symbol	min.	typ.	max.	unit
Gain data (continued)						
Delay time between signal switching and signal insertion		t_d	-25	—	+25	ns
Difference in gain between normal mode and signal insertion mode		$\Delta G_{1,3,5}$	—	—	10	%
Sandcastle pulse detector (pin 10)						
Levels for separating the following pulses:	note 7					
horizontal and vertical blanking pulses	note 8	V_{10}	1,0	1,5	2,0	V
required pulses (H+V)		V_{10}	2,1	2,5	2,9	V
horizontal pulses		V_{10}	3,0	3,5	4,0	V
required pulses (H)		V_{10}	4,1	4,5	5,0	V
clamping pulses	note 9	V_{10}	6,5	7,0	7,5	V
required pulses		V_{10}	7,6	—	12,0	V
no keying		V_{10}	—	—	1,0	V
Input current		$-I_{10}$	—	—	110	μA

Notes to the characteristics

- Values are proportional to the supply voltage.
- When $V_{11,24} < 0,4$ V during clamping time — the black levels of the inserted RGB signals are clamped on the black levels of the internal RGB signals.
When $V_{11,24} > 0,9$ V during clamping time — the black levels of the inserted RGB signals are clamped on an internal DC voltage (correct clamping of the external RGB signals is possible only when they are synchronous with the sandcastle pulse).
- When pins 21, 22 and 23 are not connected, an internal bias voltage of 5,5 V is supplied.
- Automatic cut-off control measurement occurs in the following lines after start of the vertical blanking pulse:
 - line 12: measurement of leakage current (R + G + B)
 - line 13: measurement of red cut-off current
 - line 14: measurement of green cut-off current
 - line 15: measurement of blue cut-off current
- Black level of the measured channel is nominal; the other two channels are blanked to ultra-black.
- All three channels blanked to ultra-black.
The cut-off control cycle occurs when the vertical blanking part of the sandcastle pulse contains more than 3 line pulses.
The internal blanking continues until the end of the last measured line.
The vertical blanking pulse is not allowed to contain more than 34 line pulses, otherwise another control cycle begins.

7. The sandcastle pulse is compared with three internal thresholds (proportional to V_p) and the given levels separate the various pulses.
8. Blanked to ultra-black (-25%).
9. Pulse duration $\geq 3,5 \mu s$.

APPLICATION INFORMATION

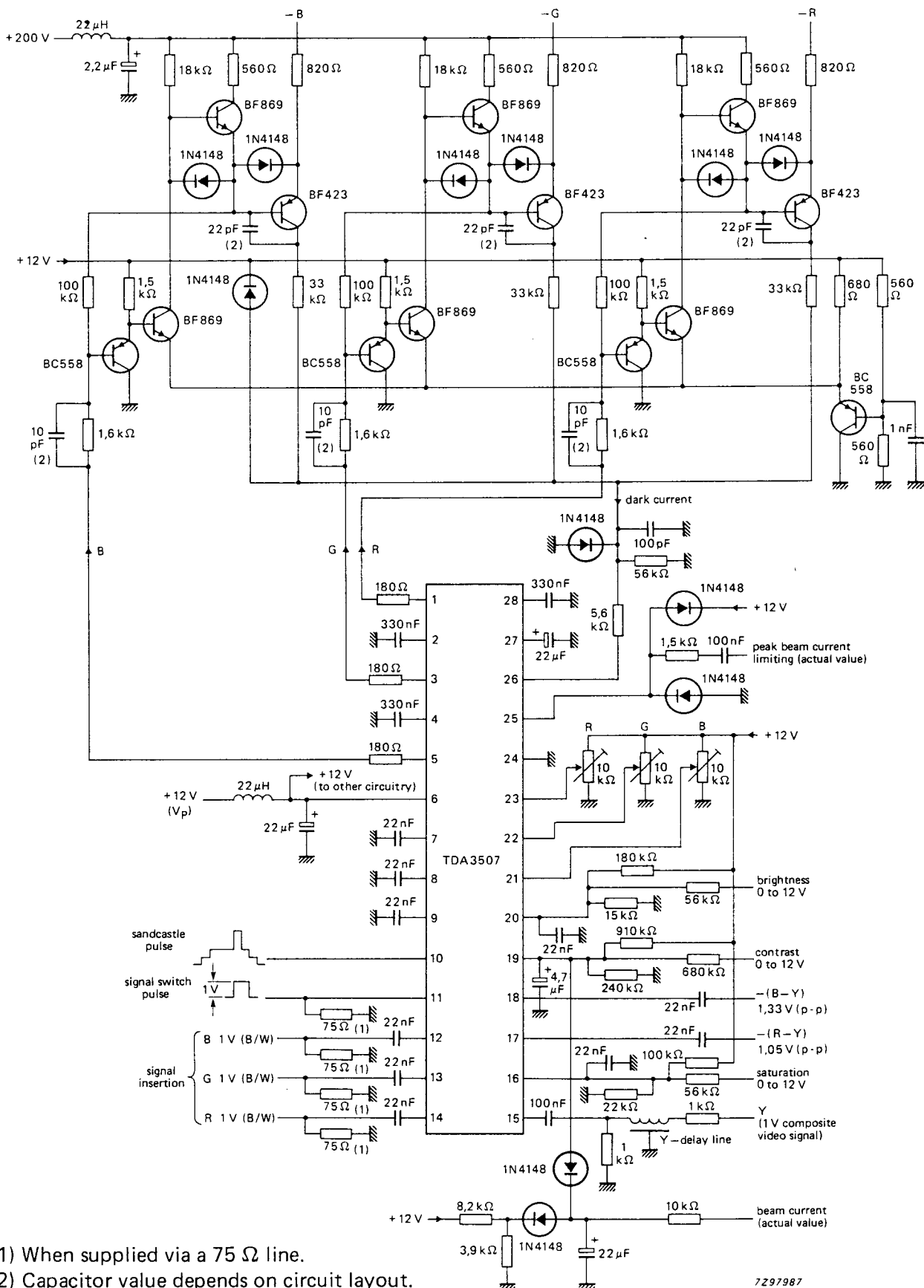

Fig. 2 Typical application circuit diagram using the TDA3507.