

VIDEO SWITCH

- 1 VIDEO OUTPUT 75Ω- 1V_{PP} NOT SWITCHED
- 1 SWITCHED VIDEO OUTPUT 2V_{PP}
- VIDEO CROSSTALK : 50dB TYPICAL
- SHORT CIRCUIT PROTECTION OF INPUTS AND OUTPUTS
- CLAMPED VIDEO INPUTS

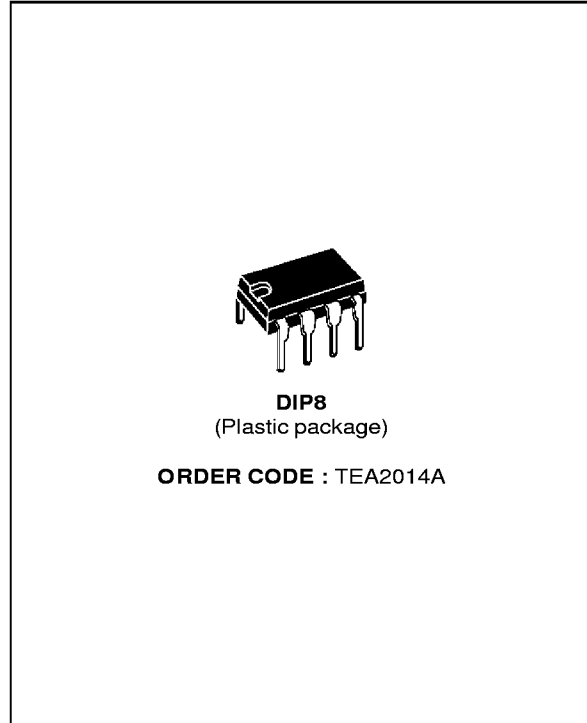

DESCRIPTION

This integrated circuit provides all video switching allowing connections between the peri TV plug and video sections in the TV set. The TEA2014A is supplied in a DIP8.

PIN CONNECTIONS

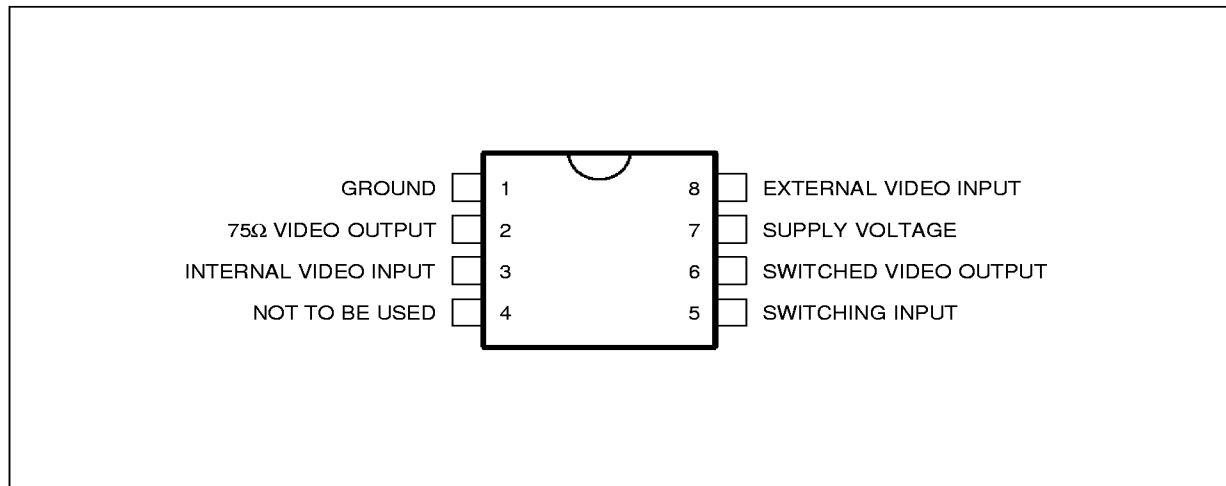

2014A-01.EPS

ABSOLUTE MAXIMUM RATINGS

Symbol	Parameter	Value	Unit
V _{CC}	Supply Voltage	18	V
T _{oper}	Operating Temperature with Load > 150 Ω on PIN 2 with Load = 75 Ω on PIN 2	0, + 100 0, + 70	°C
T _j	Junction Temperature	- 40, + 150	°C
T _{stg}	Storage Temperature	- 40, + 150	°C
-	Minimum DC Load Resistor PIN 6	600	Ω
-	Minimum DC Load Resistor PIN 2	75	Ω

2014A-01.TBL

THERMAL DATA

Symbol	Parameter	Value	Unit
R _{th (j-a)}	Junction-ambient Thermal Resistance	90	°C/W

2014A-02.TBL

ELECTRICAL CHARACTERISTICS

T_{amb} = + 25 °C, V_{CC} = 9 V (unless otherwise specified)

Symbol	Parameter	Min.	Typ.	Max.	Unit
V _{CC}	Supply Voltage Range	8	-	14	V
I _{CC}	Supply Current (no load on Pin 2 and Pin 6)	-	-	20	mA
I _{CC}	Supply Current (with 75 Ω Pin 2.1, with 600 Ω between Pin 6.1)	-	45	-	mA
P _{tot}	Total Power Dissipation with Load	-	400	-	mW

INPUTS (pin 8 and pin 3)

-	Internal Video Input Swing from Picture IF (positive Video)	-	-	4.5	V _{pp}
-	Internal Video Input Impedance (positive video)	50	-	-	kΩ
-	Internal Video Input Bias Current (positive video)	6	25	40	μA
-	External Video Input Swing (positive video)	-	-	2	V _{pp}
-	External Video Input Impedance (positive video)	50	-	-	kΩ

SWITCHED OUTPUT (pin 6) - R_{LOAD} = 600 Ω

-	Video Output Swing	4	-	-	V _{pp}
-	Video Output Dynamic Impedance	-	-	25	Ω
-	Video DC Output Voltage (sync. pulse level note 1)	1.7	2	2.4	V
-	Video Bandwith Pin 6 – from Internal Input Pin 3 (- 1 dB)	6	-	-	MHz
-	Video Bandwith Pin 6 – from External Input Pin 8 (- 3 dB)	6	-	-	MHz
-	Output Gain Pin 6 – Pin 8	+ 5	+ 6	+ 7	dB
-	Output Gain Pin 6 – Pin 3	- 1	- 0.5	0	dB

EXTERNAL OUTPUT (pin 2) - R_{LOAD} = 75 Ω

-	Video Output Swing	2.2	-	-	V _{pp}
-	Video Output Dynamic Impedance	-	10	-	Ω
-	Video DC Output Voltage (sync. pulse level , note)	1.7	2	2.4	V
-	Video Bandwidth (- 1dB)	6	-	-	MHz
-	Video Output Gain (pin 2 – pin 3)	- 1.8	- 1	- 0.4	dB

SWITCHING INPUT (pin 5)

-	Switching Input Unactive Low Level or Unconnected Pin (TV receiving)	0	-	3	V
-	Switching Input Active Level (ext. receiving)	7	-	V _{CC}	V
-	Switching Input Impedance	10	-	-	kΩ

2014A-03.TBL

Note : Use a video signal with a synchro pulse in order to make the clamp work in a correct way. (75Ω to the ground and 10μF in series).

ELECTRICAL CHARACTERISTICS (continued)

T_{amb} = + 25 °C, V_{CC} = 9 V (unless otherwise specified)

Symbol	Parameter	Min.	Typ.	Max.	Unit
OTHER DYNAMIC FEATURES					
–	Video rejection Between Two Inputs 1MHz 1kHz	– – 50	– 50 –	– –	dB dB
–	Linearity Distortion Luma (test line 17) Chroma (test line 331) Intermodulation Luma – Chroma (test line 331)	– – –	2 2 5	– – –	% % %
–	Supply Voltage Rejection (1 kHz)	40	50	–	dB

2014A-04.TBL

TYPICAL APPLICATION

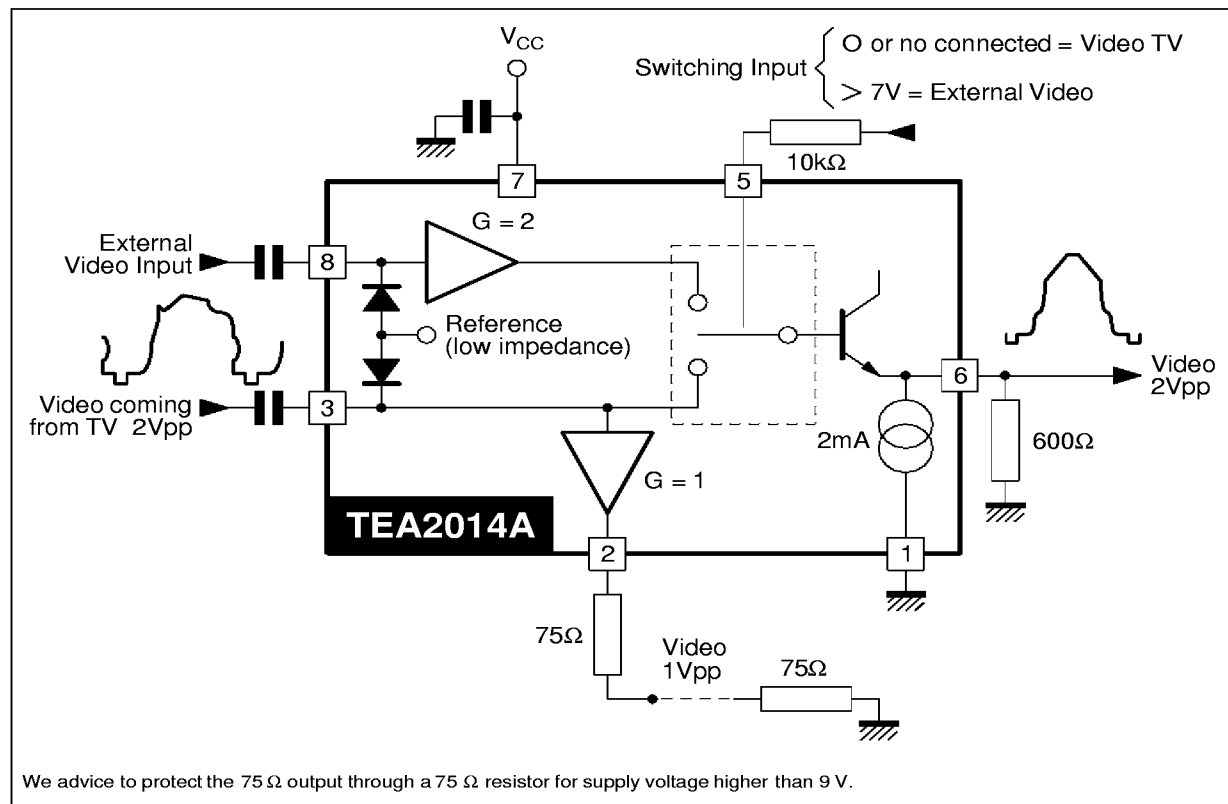

2014A-02.EPS

TEA2014A

PACKAGE MECHANICAL DATA
8 PINS – PLASTIC DIP

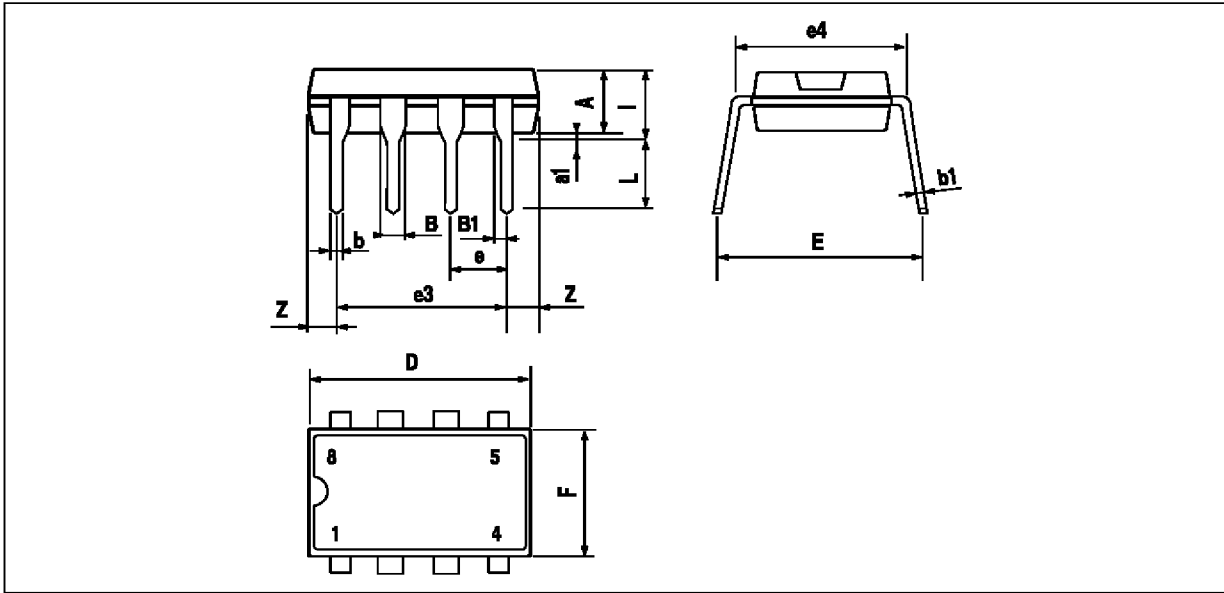

PM-DIP8EFS

Dimensions	Millimeters			Inches		
	Min.	Typ.	Max.	Min.	Typ.	Max.
A		3.32			0.131	
a1	0.51			0.020		
B	1.15		1.65	0.045		0.065
b	0.356		0.55	0.014		0.022
b1	0.204		0.304	0.008		0.012
D			10.92			0.430
E	7.95		9.75	0.313		0.384
e		2.54			0.100	
e3		7.62			0.300	
e4		7.62			0.300	
F			6.6			0.260
l			5.08			0.200
L	3.18		3.81	0.125		0.150
Z			1.52			0.060

DIP8.TBL

Information furnished is believed to be accurate and reliable. However, SGS-THOMSON Microelectronics assumes no responsibility for the consequences of use of such information nor for any infringement of patents or other rights of third parties which may result from its use. No licence is granted by implication or otherwise under any patent or patent rights of SGS-THOMSON Microelectronics. Specifications mentioned in this publication are subject to change without notice. This publication supersedes and replaces all information previously supplied. SGS-THOMSON Microelectronics products are not authorized for use as critical components in life support devices or systems without express written approval of SGS-THOMSON Microelectronics.

© 1996 SGS-THOMSON Microelectronics - All Rights Reserved

Purchase of I²C Components of SGS-THOMSON Microelectronics, conveys a license under the Phillips I²C Patent. Rights to use these components in a I²C system, is granted provided that the system conforms to the I²C Standard Specifications as defined by Phillips.

SGS-THOMSON Microelectronics GROUP OF COMPANIES

Australia - Brazil - Canada - China - France - Germany - Hong Kong - Italy - Japan - Korea - Malaysia - Malta - Morocco
The Netherlands - Singapore - Spain - Sweden - Switzerland - Taiwan - Thailand - United Kingdom - U.S.A.