

ULTRALOW-NOISE, HIGH PSRR, FAST RF 200-mA LOW-DROPOUT LINEAR REGULATORS IN NANOSTAR™ WAFER CHIP SCALE AND SOT23

FEATURES

- 200-mA RF Low-Dropout Regulator With Enable
- Available in 1.8-V, 2.5-V, 2.8-V, 2.85-V, 3-V, 3.3-V, 4.75-V, and Adj (1.22 V to 5.5 V)
- High PSRR (70 dB at 10 kHz)
- Ultralow Noise (32 μV)
- Fast Start-Up Time (50 μs)
- Stable With a 2.2- μF Ceramic Capacitor
- Excellent Load/Line Transient Response
- Very Low Dropout Voltage (112 mV at Full Load, TPS79330)
- 5-Pin SOT23 (DBV) and NanoStar Wafer Chip Scale (YEQ) Packages

APPLICATIONS

- RF: VCOs, Receivers, ADCs
- Audio
- Cellular and Cordless Telephones
- Bluetooth™, Wireless LAN
- Handheld Organizers, PDAs

DESCRIPTION

The TPS793xx family of low-dropout (LDO) low-power linear voltage regulators features high power supply rejection ratio (PSRR), ultralow noise, fast start-up, and excellent line and load transient responses in NanoStar wafer chip scale and SOT23 packages. NanoStar packaging gives an ultrasmall footprint as well as an ultralow profile and package weight, making it ideal for portable applications such as handsets and PDAs. Each device in the family is stable, with a small 2.2- μF ceramic capacitor on the output. The TPS793xx family uses an advanced, proprietary BiCMOS fabrication process to yield extremely low dropout voltages (e.g., 112 mV at 200 mA, TPS79330). Each device achieves fast start-up times (approximately 50 μs with a 0.001- μF bypass capacitor) while consuming very low quiescent current (170 μA typical). Moreover, when the device is placed in standby mode, the supply current is reduced to less than 1 μA . The TPS79328 exhibits approximately 32 μV_{RMS} of output voltage noise with a 0.1- μF bypass capacitor. Applications with analog components that are noise sensitive, such as portable RF electronics, benefit from the high PSRR and low-noise features as well as the fast response time.

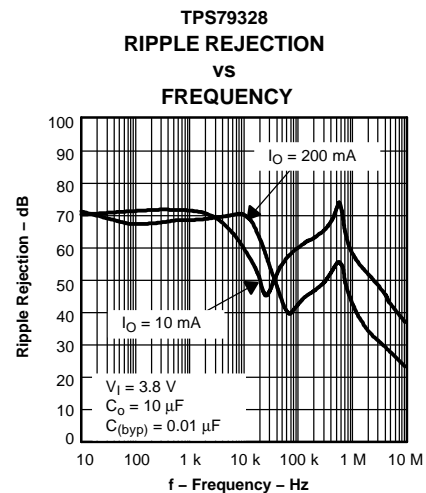
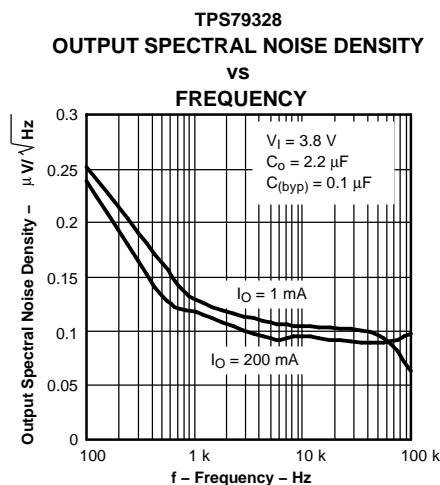
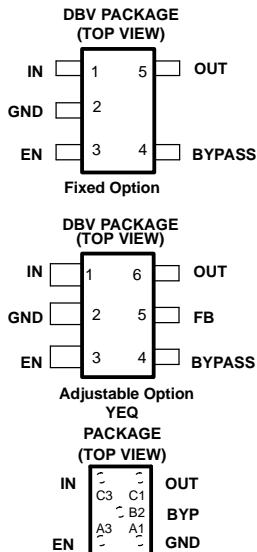

Please be aware that an important notice concerning availability, standard warranty, and use in critical applications of Texas Instruments semiconductor products and disclaimers thereto appears at the end of this data sheet.

Bluetooth is a trademark of Bluetooth Sig, Inc.
NANOSTAR is a trademark of Texas Instruments.

AVAILABLE OPTIONS⁽¹⁾

T _J	VOLTAGE	PACKAGE	PART NUMBER	SYMBOL
-40°C to 125°C	1.22 to 5.5 V	SOT23 (DBV)	TPS79301DBVR	PGVI
	1.8 V		TPS79318DBVR	PHHI
	1.8 V	CSP (YEQ)	TPS79318YEQ	E3
	2.5 V	SOT23 (DBV)	TPS79325DBVR	PGWI
	2.5 V	CSP (YEQ)	TPS79325YEQ	E4
	2.8 V	SOT23 (DBV)	TPS79328DBVR	PGXI
	2.8 V	CSP (YEQ)	TPS79328YEQ	E2
	2.85 V	SOT23 (DBV)	TPS793285DBVR	PHII
	2.85 V	CSP (YEQ)	TPS793285YEQ	E5
	3 V	SOT23 (DBV)	TPS79330DBVR	PGYI
	3 V	CSP (YEQ)	TPS79330YEQ	E6
	3.3 V	SOT23 (DBV)	TPS79333DBVR	PHUI
	4.75 V		TPS793475DBVR	PHJI

(1) DBVR indicates tape and reel of 3000 parts. YEQR indicates tape and reel of 3000 parts. YEQT indicates tape and reel of 250 parts.

ABSOLUTE MAXIMUM RATINGS

over operating temperature range (unless otherwise noted)⁽¹⁾

	UNIT
V _{IN} range	-0.3 V to 6 V
V _{EN} range	-0.3 V to V _{IN} + 0.3 V
V _{OUT} range	-0.3 V to 6 V
Peak output current	Internally limited
ESD rating, HBM	2 kV
ESD rating, CDM	500 V
Continuous total power dissipation	See Dissipation Ratings Table
Operating junction temperature range, DBV package	-40°C to 150°C
Operating junction temperature range, YEQ package	-40°C to 125°C
Storage temperature range, T _{stg}	-65°C to 150°C

(1) Stresses beyond those listed under *absolute maximum ratings* may cause permanent damage to the device. These are stress ratings only, and functional operation of the device at these or any other conditions beyond those indicated under *recommended operating conditions* is not implied. Exposure to absolute-maximum-rated conditions for extended periods may affect device reliability.

DISSIPATION RATINGS TABLE

BOARD	PACKAGE	R _{θJC}	R _{θJA}	DERATING FACTOR ABOVE T _A = 25°C	T _A ≤ 25°C POWER RATING	T _A = 70°C POWER RATING	T _A = 85°C POWER RATING
Low-K ⁽¹⁾	DBV	65°C/W	255°C/W	3.9 mW/°C	390 mW	215 mW	155 mW
High-K ⁽²⁾	DBV	65°C/W	180°C/W	5.6 mW/°C	560 mW	310 mW	225 mW
Low-K ⁽¹⁾	YEQ	27°C/W	255°C/W	3.9 mW/°C	390 mW	215 mW	155 mW
High-K ⁽²⁾	YEQ	27°C/W	190°C/W	5.3 mW/°C	530 mW	296 mW	216 mW

- (1) The JEDEC low-K (1s) board design used to derive this data was a 3-inch x 3-inch, two layer board with 2 ounce copper traces on top of the board.
- (2) The JEDEC high-K (2s2p) board design used to derive this data was a 3-inch x 3-inch, multilayer board with 1 ounce internal power and ground planes and 2 ounce copper traces on top and bottom of the board.

ELECTRICAL CHARACTERISTICS

over recommended operating temperature range $T_J = -40$ to 125 °C, $V_{EN} = V_{IN}$, $V_{IN} = V_{OUT(nom)} + 1$ V⁽¹⁾, $I_{OUT} = 1$ mA, $C_{OUT} = 10$ μ F, $C_{BYPASS} = 0.01$ μ F (unless otherwise noted). Typical values are at 25°C.

PARAMETER	TEST CONDITIONS	MIN	TYP	MAX	UNIT		
V_{IN} Input voltage ⁽¹⁾		2.7		5.5	V		
I_{OUT} Continuous output current		0		200	mA		
V_{FB} Internal reference (TPS79301)		1.201	1.225	1.250	V		
Output voltage range (TPS79301)		V_{FB}		$5.5 - V_{DO}$	V		
T_J Operating junction temperature		-40		125	°C		
Output voltage	TPS79318	$0 \mu A < I_{OUT} < 200$ mA,	2.8 V < $V_{IN} < 5.5$ V	1.764	1.8	1.836	V
	TPS79325	$0 \mu A < I_{OUT} < 200$ mA,	3.5 V < $V_{IN} < 5.5$ V	2.45	2.5	2.55	V
	TPS79328	$0 \mu A < I_{OUT} < 200$ mA,	3.8 V < $V_{IN} < 5.5$ V	2.744	2.8	2.856	V
	TPS793285	$0 \mu A < I_{OUT} < 200$ mA,	3.85 V < $V_{IN} < 5.5$ V	2.793	2.85	2.907	V
	TPS79330	$0 \mu A < I_{OUT} < 200$ mA,	4 V < $V_{IN} < 5.5$ V	2.94	3	3.06	V
	TPS79333	$0 \mu A \leq I_{OUT} < 200$ mA,	4.3 V < $V_{IN} < 5.5$ V	3.234	3.3	3.366	V
	TPS793475	$0 \mu A < I_{OUT} < 200$ mA,	5.25 V < $V_{IN} < 5.5$ V	4.655	4.75	4.845	V
Quiescent current (GND current)	$0 \mu A < I_{OUT} < 200$ mA		170	220	μ A		
Load regulation ($\Delta V_{OUT}/I_{OUT}$)	$0 \mu A < I_{OUT} < 200$ mA, $T_J = 25^\circ\text{C}$		5		mV		
Line regulation ($\Delta V_{OUT}/V_{IN}$) ⁽¹⁾	$V_{OUT} + 1$ V < $V_{IN} \leq 5.5$ V		0.05	0.12	%/V		
Output noise voltage (TPS79328)	BW = 200 Hz to 100 kHz, $I_{OUT} = 200$ mA	$C_{BYPASS} = 0.001$ μ F		55	μ V _{RMS}		
		$C_{BYPASS} = 0.0047$ μ F		36			
		$C_{BYPASS} = 0.01$ μ F		33			
		$C_{BYPASS} = 0.1$ μ F		32			
Time, start-up (TPS79328)	$R_L = 14$ Ω , $C_{OUT} = 1$ μ F	$C_{BYPASS} = 0.001$ μ F		50	μ s		
		$C_{BYPASS} = 0.0047$ μ F		70			
		$C_{BYPASS} = 0.01$ μ F		100			
Output current limit	$V_{OUT} = 0$ V	285		600	mA		
Standby current	$V_{EN} = 0$ V, 2.7 V < $V_{IN} < 5.5$ V		0.07	1	μ A		
High level enable input voltage	2.7 V < $V_{IN} < 5.5$ V	1.7		V_{IN}	V		
Low level enable input voltage	2.7 V < $V_{IN} < 5.5$ V	0		0.7	V		
Input current (EN)	$V_{EN} = 0$	-1		1	μ A		
Input current (FB) (TPS79301)	FB = 1.8 V			1	μ A		
Power supply ripple rejection	TPS79328	f = 100 Hz, $T_J = 25^\circ\text{C}$, $I_{OUT} = 10$ mA		70	dB		
		f = 100 Hz, $T_J = 25^\circ\text{C}$, $I_{OUT} = 200$ mA		68			
		f = 10 kHz, $T_J = 25^\circ\text{C}$, $I_{OUT} = 200$ mA		70			
		f = 100 kHz, $T_J = 25^\circ\text{C}$, $I_{OUT} = 200$ mA		43			
Dropout voltage ⁽²⁾ ($V_{IN} = V_{OUT(typ)} - 0.1$ V)	TPS79328	$I_{OUT} = 200$ mA		120	200	mV	
	TPS793285	$I_{OUT} = 200$ mA		120	200		
	TPS79330	$I_{OUT} = 200$ mA		112	200		
	TPS79333	$I_{OUT} = 200$ mA		102	180		
	TPS793475	$I_{OUT} = 200$ mA		77	125		
UVLO threshold	V_{CC} rising	2.25		2.65	V		
UVLO hysteresis			100		mV		

(1) Minimum V_{IN} is 2.7 V or $V_{OUT} + V_{DO}$, whichever is greater.

(2) Dropout is not measured for the TPS79318 and TPS79325 since minimum $V_{IN} = 2.7$ V.

FUNCTIONAL BLOCK DIAGRAMS

ADJUSTABLE VERSION

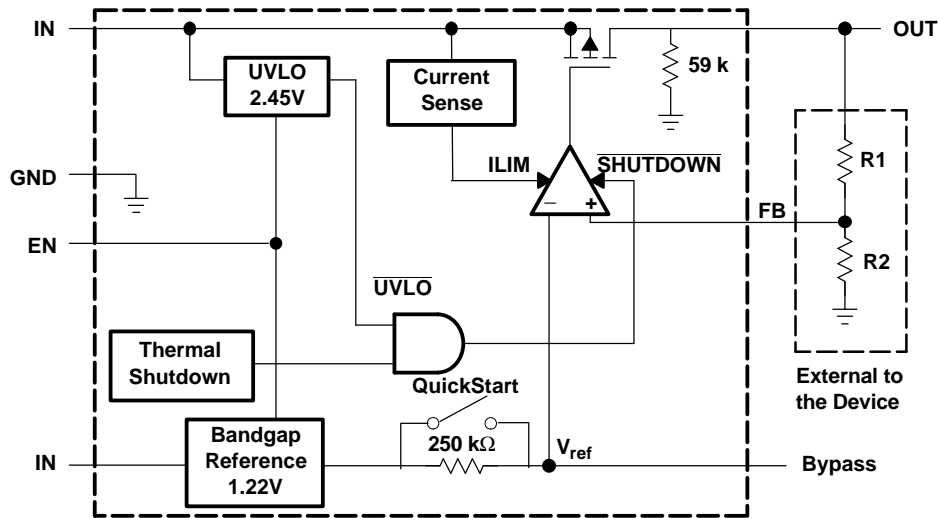

FIXED VERSION

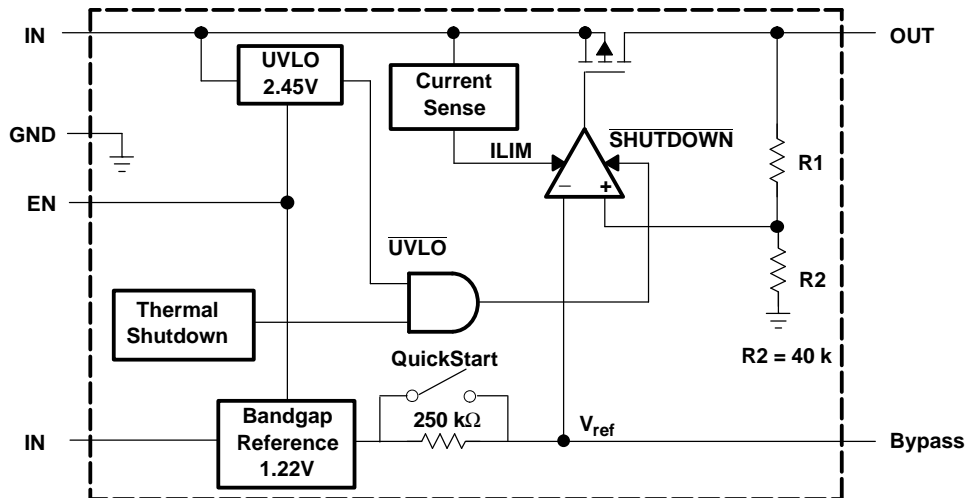

Terminal Functions

TERMINAL				DESCRIPTION
NAME	SOT23 ADJ	SOT23 FIXED	CSP FIXED	
BYPASS	4	4	B2	An external bypass capacitor, connected to this terminal in conjunction with an internal resistor, creates a low-pass filter to further reduce regulator noise.
EN	3	3	A3	The EN terminal is an input which enables or shuts down the device. When EN goes to a logic high, the device will be enabled. When the device goes to a logic low, the device is in shutdown mode.
FB	5	N/A	N/A	This terminal is the feedback input voltage for the adjustable device.
GND	2	2	A1	Regulator ground
IN	1	1	C3	Unregulated input to the device.
OUT	6	5	C1	Output of the regulator.

TYPICAL CHARACTERISTICS (SOT23 PACKAGE)

TPS79328
OUTPUT VOLTAGE
VS
OUTPUT CURRENT

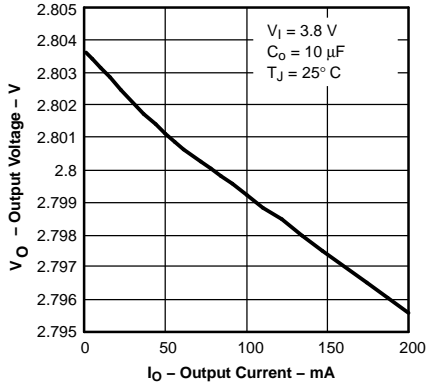

Figure 1.

TPS79328
OUTPUT VOLTAGE
VS
JUNCTION TEMPERATURE

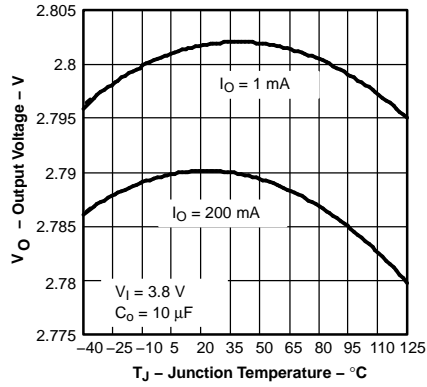

Figure 2.

TPS79328
GROUND CURRENT
VS
JUNCTION TEMPERATURE

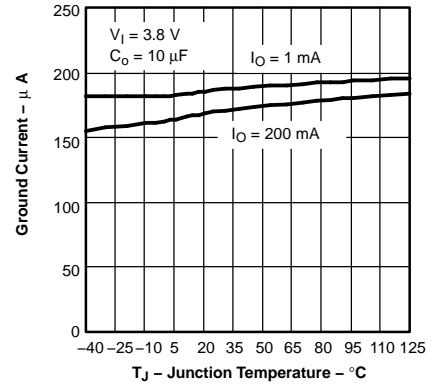

Figure 3.

TPS79328
OUTPUT SPECTRAL NOISE DENSITY
VS
FREQUENCY

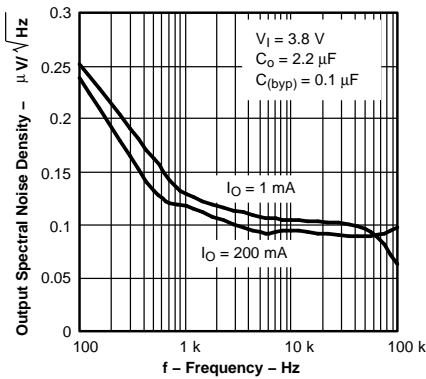

Figure 4.

TPS79328
OUTPUT SPECTRAL NOISE DENSITY
VS
FREQUENCY

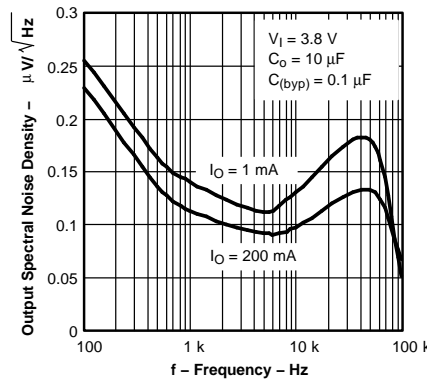

Figure 5.

TPS79328
OUTPUT SPECTRAL NOISE DENSITY
VS
FREQUENCY

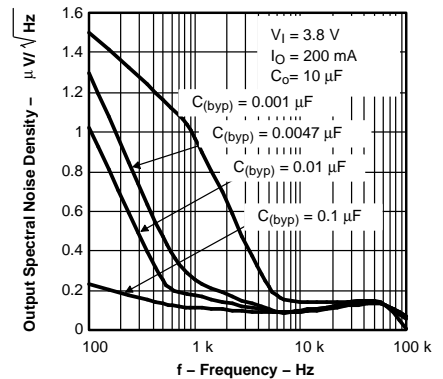

Figure 6.

ROOT MEAN SQUARED OUTPUT
NOISE
VS
BYPASS CAPACITANCE

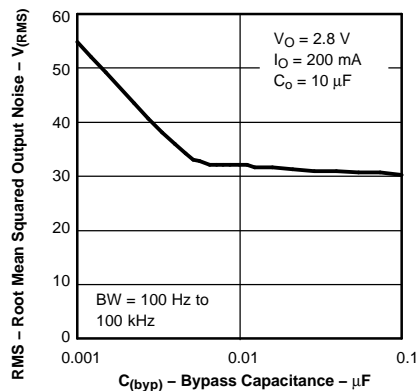

Figure 7.

OUTPUT IMPEDANCE
VS
FREQUENCY

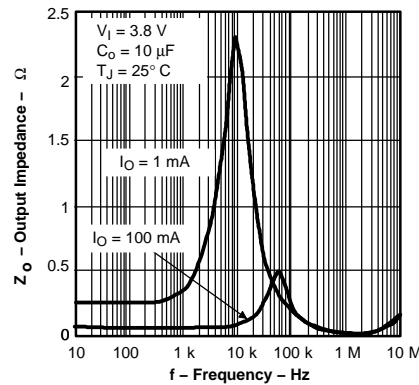

Figure 8.

TPS79328
DROPOUT VOLTAGE
VS
JUNCTION TEMPERATURE

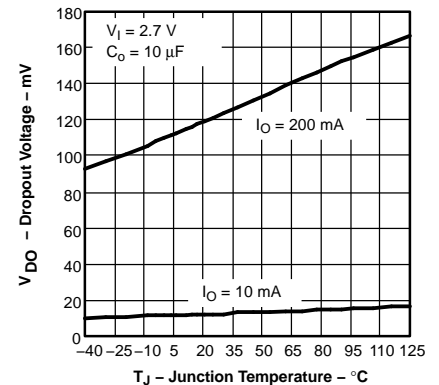

Figure 9.

TYPICAL CHARACTERISTICS (SOT23 PACKAGE) (continued)

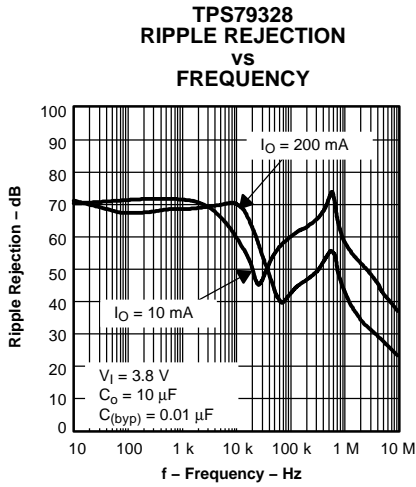

Figure 10.

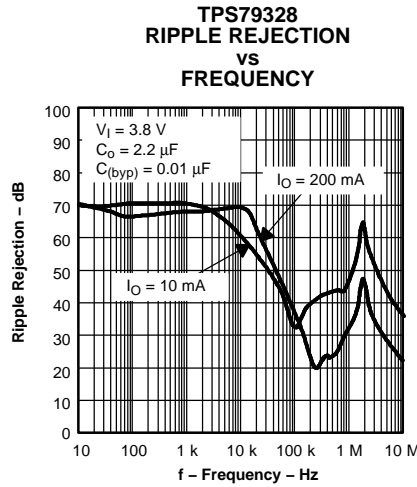

Figure 11.

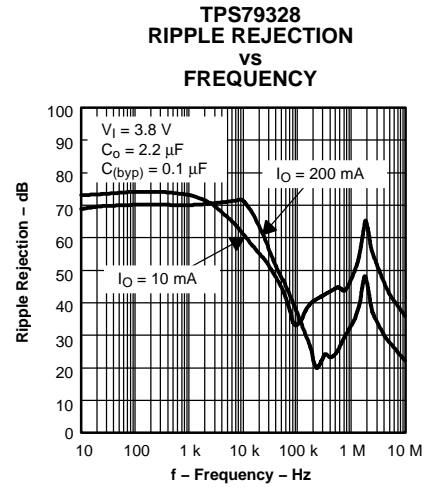

Figure 12.

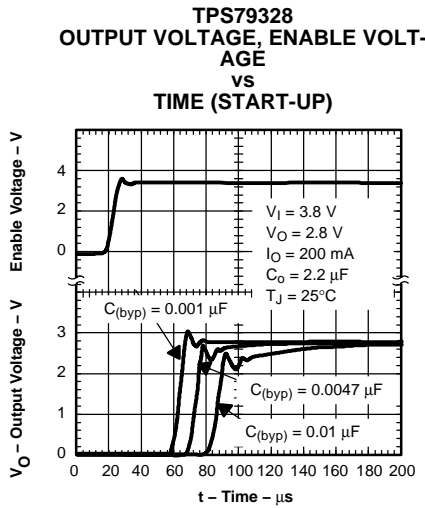

Figure 13.

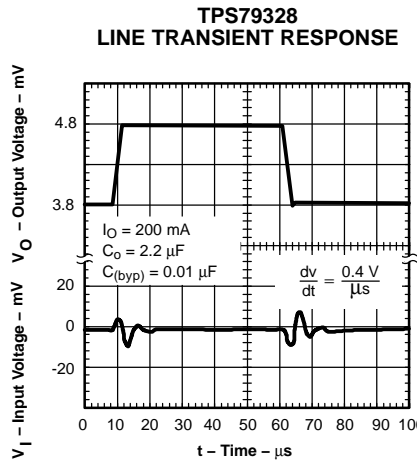

Figure 14.

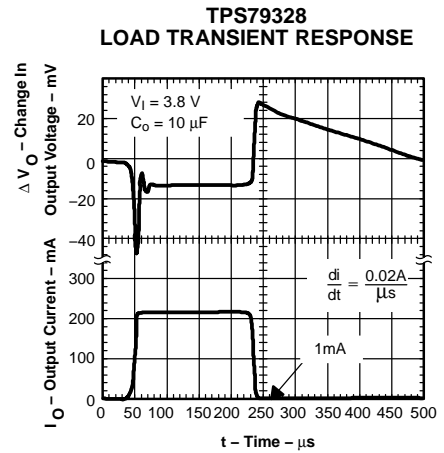

Figure 15.

TYPICAL CHARACTERISTICS (SOT23 PACKAGE) (continued)

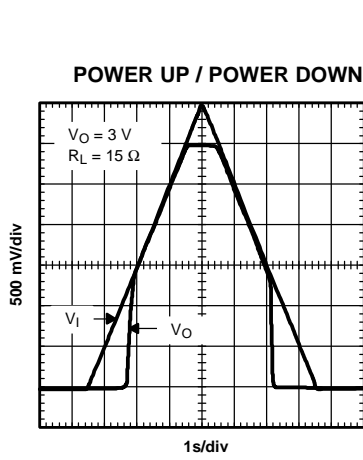

Figure 16.

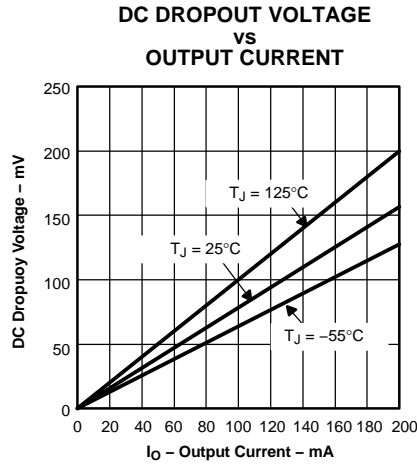

Figure 17.

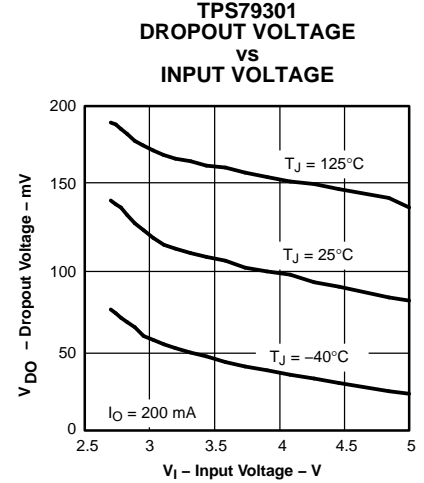

Figure 18.

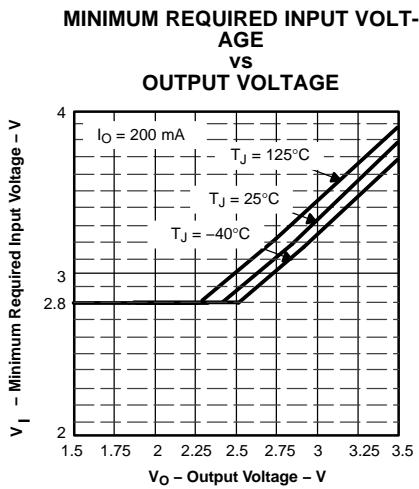

Figure 19.

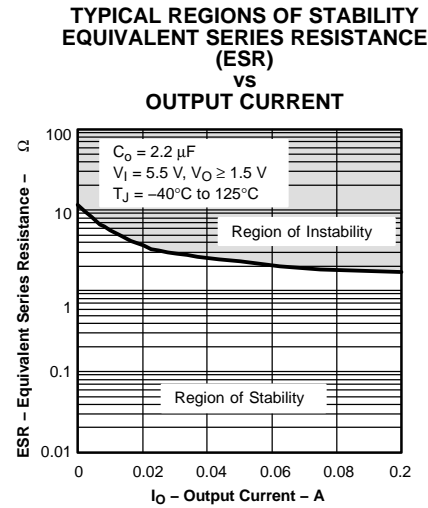

Figure 20.

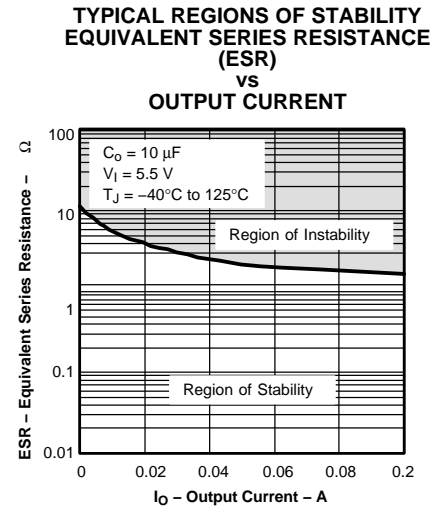

Figure 21.

APPLICATION INFORMATION

The TPS793xx family of low-dropout (LDO) regulators has been optimized for use in noise-sensitive battery-operated equipment. The device features extremely low dropout voltages, high PSRR, ultralow output noise, low quiescent current (170 μA typically), and enable-input to reduce supply currents to less than 1 μA when the regulator is turned off.

A typical application circuit is shown in Figure 22.

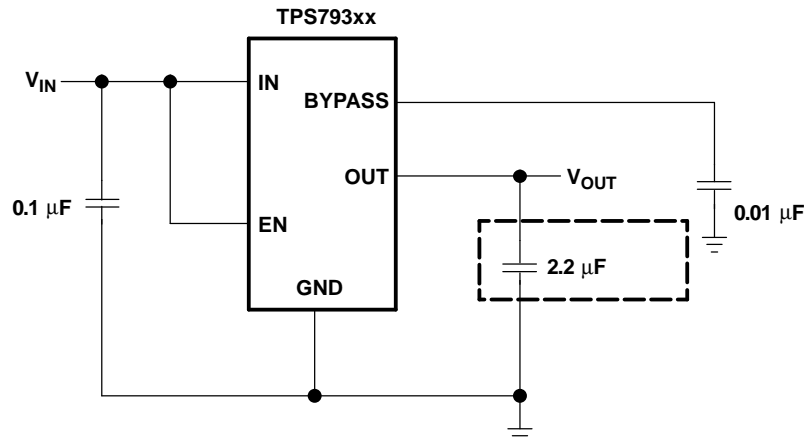

Figure 22. Typical Application Circuit

External Capacitor Requirements

A 0.1- μF or larger ceramic input bypass capacitor, connected between IN and GND and located close to the TPS793xx, is required for stability and improves transient response, noise rejection, and ripple rejection. A higher-value input capacitor may be necessary if large, fast-rise-time load transients are anticipated or the device is located several inches from the power source.

Like most low dropout regulators, the TPS793xx requires an output capacitor connected between OUT and GND to stabilize the internal control loop. The minimum recommended capacitance is 2.2 μF . Any 2.2- μF or larger ceramic capacitor is suitable, provided the capacitance does not vary significantly over temperature. If load current is not expected to exceed 100 mA, a 1.0- μF ceramic capacitor can be used.

The internal voltage reference is a key source of noise in an LDO regulator. The TPS793xx has a BYPASS pin which is connected to the voltage reference through a 250-k Ω internal resistor. The 250-k Ω internal resistor, in conjunction with an external bypass capacitor connected to the BYPASS pin, creates a low pass filter to reduce the voltage reference noise and, therefore, the noise at the regulator output. In order for the regulator to operate properly, the current flow out of the BYPASS pin must be at a minimum, because any leakage current creates an IR drop across the internal resistor thus creating an output error. Therefore, the bypass capacitor must have minimal leakage current. The bypass capacitor should be no more than 0.1- μF to ensure that it is fully charged during the quickstart time provided by the internal switch shown in the Functional Block Diagrams

As an example, the TPS79328 exhibits only 32 μV_{RMS} of output voltage noise using a 0.1- μF ceramic bypass capacitor and a 2.2- μF ceramic output capacitor. Note that the output starts up slower as the bypass capacitance increases due to the RC time constant at the BYPASS pin that is created by the internal 250-k Ω resistor and external capacitor.

Board Layout Recommendation to Improve PSRR and Noise Performance

To improve ac measurements like PSRR, output noise, and transient response, it is recommended that the board be designed with separate ground planes for V_{IN} and V_{OUT} , with each ground plane connected only at the GND pin of the device. In addition, the ground connection for the bypass capacitor should connect directly to the GND pin of the device.

APPLICATION INFORMATION (continued)

Power Dissipation and Junction Temperature

Specified regulator operation is assured to a junction temperature of 125°C; the maximum junction temperature should be restricted to 125°C under normal operating conditions. This restriction limits the power dissipation the regulator can handle in any given application. To ensure the junction temperature is within acceptable limits, calculate the maximum allowable dissipation, $P_{D(max)}$, and the actual dissipation, P_D , which must be less than or equal to $P_{D(max)}$.

The maximum power dissipation limit is determined using Equation 1:

$$P_{D(max)} = \frac{T_{Jmax} - T_A}{R_{\theta JA}} \quad (1)$$

Where:

- T_{Jmax} is the maximum allowable junction temperature.
- $R_{\theta JA}$ is the thermal resistance junction-to-ambient for the package (see the Dissipation Ratings Table).
- T_A is the ambient temperature.

The regulator dissipation is calculated using Equation 2:

$$P_D = (V_{IN} - V_{OUT}) \times I_{OUT} \quad (2)$$

Power dissipation resulting from quiescent current is negligible. Excessive power dissipation triggers the thermal protection circuit.

Programming the TPS79301 Adjustable LDO Regulator

The output voltage of the TPS79301 adjustable regulator is programmed using an external resistor divider as shown in Figure 23. The output voltage is calculated using Equation 3:

$$V_{OUT} = V_{REF} \times \left(1 + \frac{R_1}{R_2} \right) \quad (3)$$

Where:

- $V_{REF} = 1.2246$ V typ (the internal reference voltage)

Resistors R1 and R2 should be chosen for approximately 50- μ A divider current. Lower value resistors can be used for improved noise performance, but the solution consumes more power. Higher resistor values should be avoided as leakage current into/out of FB across R1/R2 creates an offset voltage that artificially increases/decreases the feedback voltage and thus erroneously decreases/increases V_{OUT} . The recommended design procedure is to choose $R_2 = 30.1$ k Ω to set the divider current at 50 μ A, $C_1 = 15$ pF for stability, and then calculate R1 using Equation 4:

$$R_1 = \left(\frac{V_{OUT}}{V_{ref} - 1} \right) \times R_2 \quad (4)$$

In order to improve the stability of the adjustable version, it is suggested that a small compensation capacitor be placed between OUT and FB. For voltages <1.8 V, the value of this capacitor should be 100 pF. For voltages >1.8 V, the approximate value of this capacitor can be calculated as shown in Equation 5:

$$C_1 = \frac{(3 \times 10^{-7}) \times (R_1 + R_2)}{(R_1 \times R_2)} \quad (5)$$

The suggested value of this capacitor for several resistor ratios is shown in the table below. If this capacitor is not used (such as in a unity-gain configuration) or if an output voltage <1.8 V is chosen, then the minimum recommended output capacitor is 4.7 μ F instead of 2.2 μ F.

APPLICATION INFORMATION (continued)

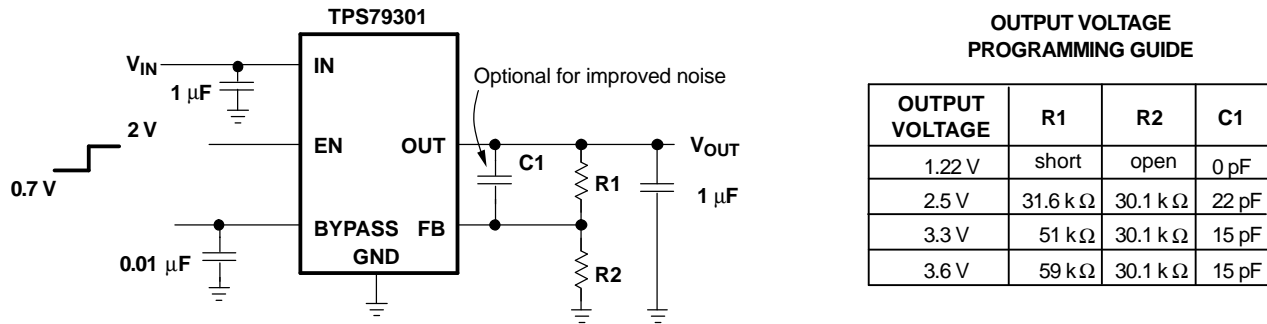

Figure 23. TPS79301 Adjustable LDO Regulator Programming

Regulator Protection

The TPS793xx PMOS-pass transistor has a built-in back diode that conducts reverse current when the input voltage drops below the output voltage (e.g., during power down). Current is conducted from the output to the input and is not internally limited. If extended reverse voltage operation is anticipated, external limiting might be appropriate.

The TPS793xx features internal current limiting and thermal protection. During normal operation, the TPS793xx limits output current to approximately 400 mA. When current limiting engages, the output voltage scales back linearly until the overcurrent condition ends. While current limiting is designed to prevent gross device failure, care should be taken not to exceed the power dissipation ratings of the package or the absolute maximum voltage ratings of the device. If the temperature of the device exceeds approximately 165°C, thermal-protection circuitry shuts it down. Once the device has cooled down to below approximately 140°C, regulator operation resumes.

APPLICATION INFORMATION (continued)

TPS793xxYEQ NanoStar™ Wafer Chip Scale Information

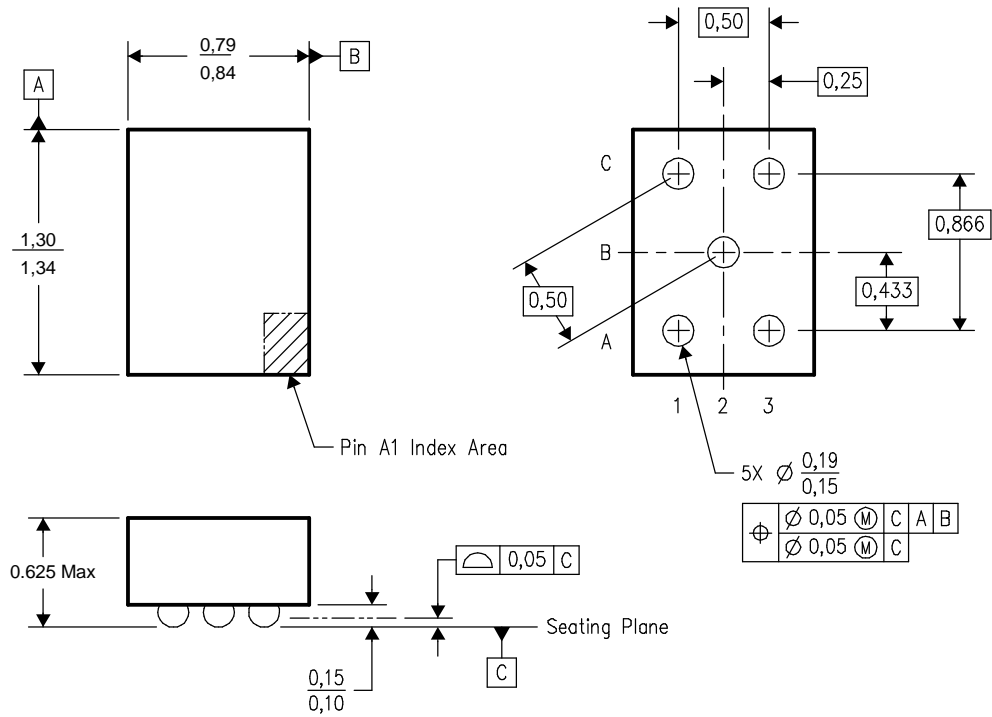

- NOTES: A. All linear dimensions are in millimeters.
 B. This drawing is subject to change without notice.
 C. NanoStar™ package configuration.
 D. This package is tin-lead (SnPb), consult the factory for availability of lead-free material.

NanoStar is a trademark of Texas Instruments.

Figure 24. NanoStar™ Wafer Chip Scale Package

DBV (R-PDSO-G5)

PLASTIC SMALL-OUTLINE PACKAGE

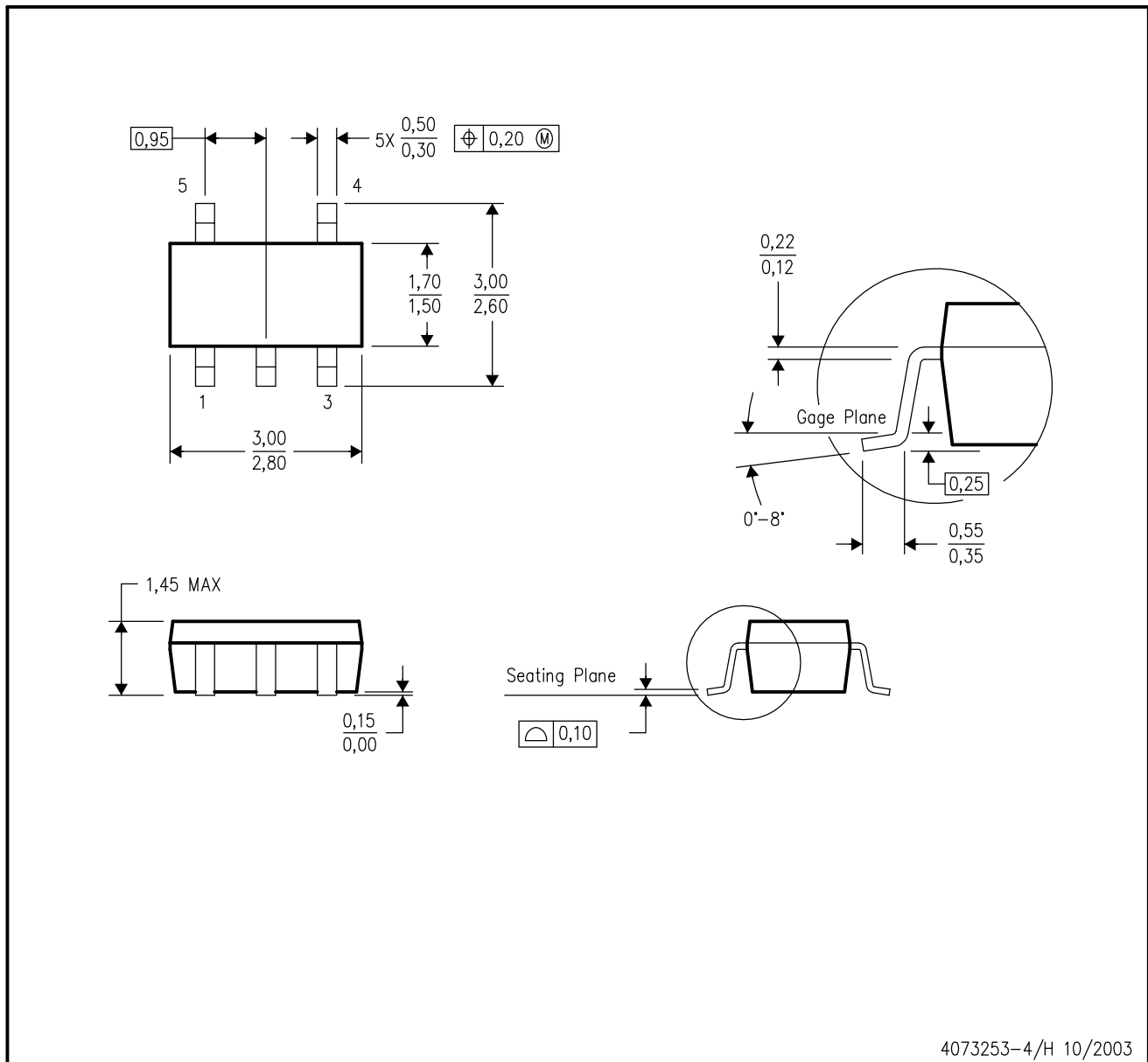

- NOTES:
- A. All linear dimensions are in millimeters.
 - B. This drawing is subject to change without notice.
 - C. Body dimensions do not include mold flash or protrusion.
 - D. Falls within JEDEC MO-178 Variation AA.

DBV (R-PDSO-G6)

PLASTIC SMALL-OUTLINE PACKAGE

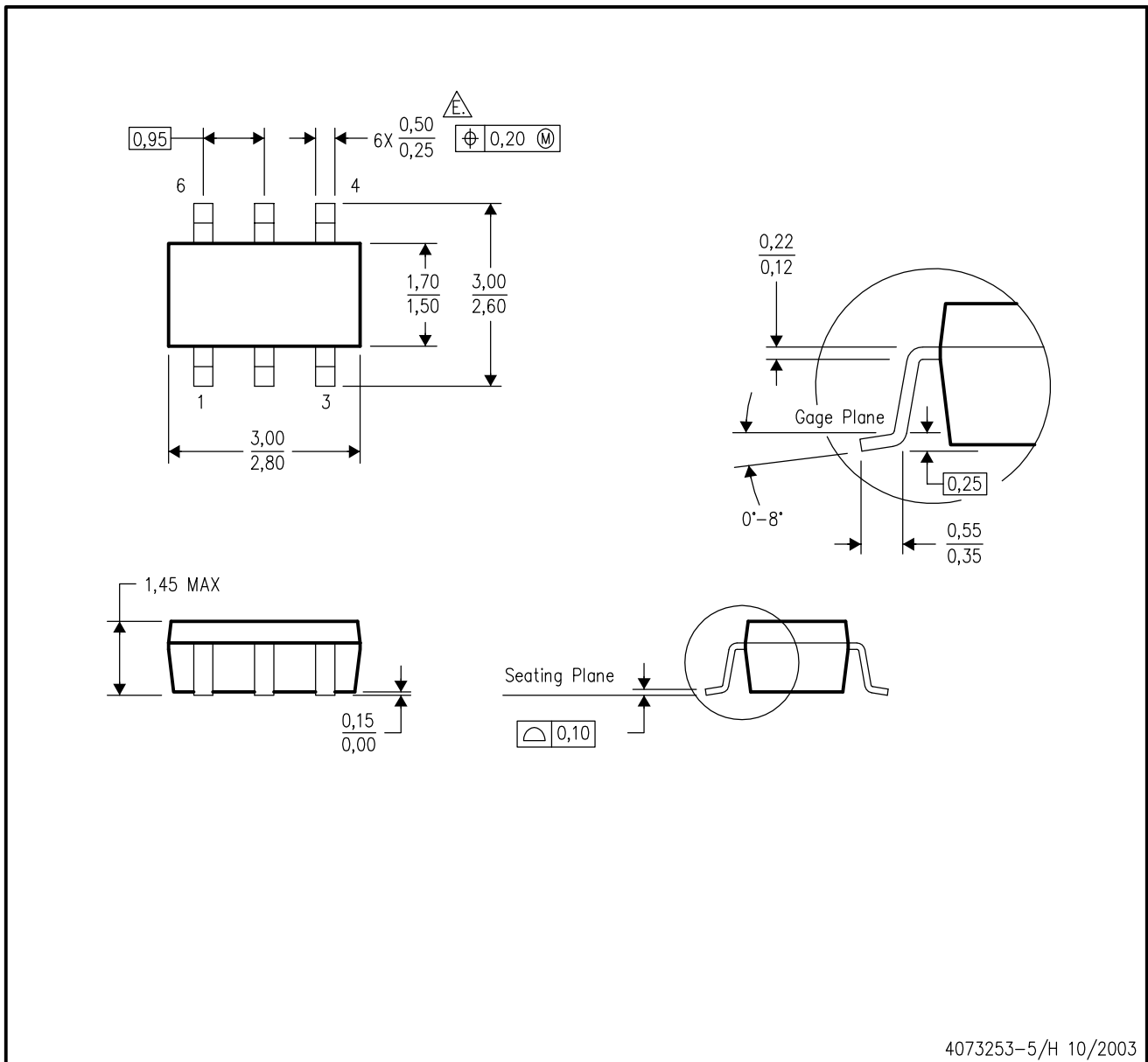

4073253-5/H 10/2003

- NOTES:
- A. All linear dimensions are in millimeters.
 - B. This drawing is subject to change without notice.
 - C. Body dimensions do not include mold flash or protrusion.
 - D. Leads 1,2,3 may be wider than leads 4,5,6 for package orientation.
 - $\triangle E$ Falls within JEDEC MO-178 Variation AB, except minimum lead width.

YEQ (R-XBGA-N5)

DIE-SIZE BALL GRID ARRAY

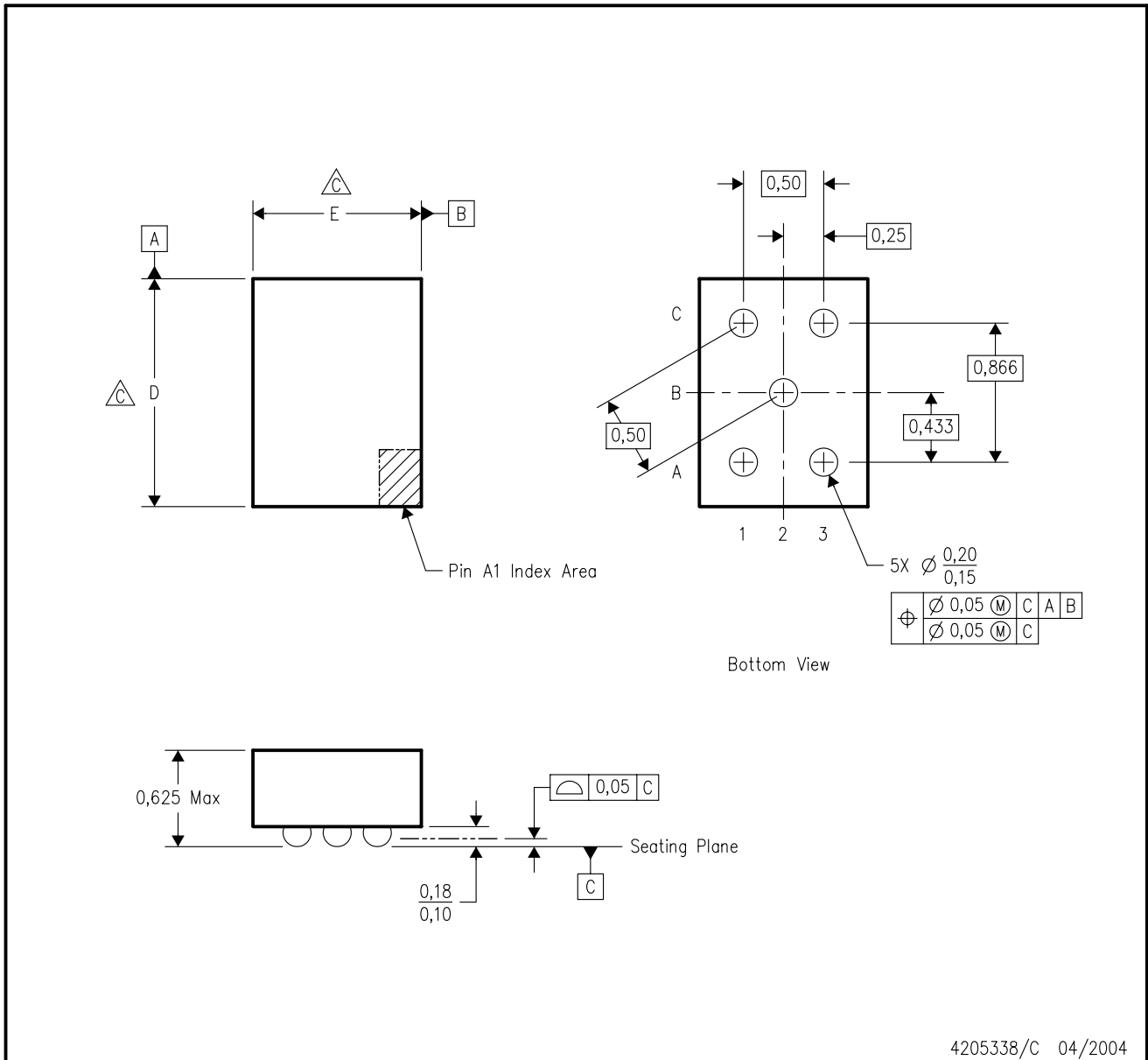

- Notes:
- A. All linear dimensions are in millimeters.
 - B. This drawing is subject to change without notice.
 - △ Devices in this YEQ package can have dimension D ranging from 1.17 to 1.67 and dimension E ranging from 0.80 to 1.30. To determine the exact package size of a particular device, refer to the device datasheet or contact a local TI representative.
 - D. NanoStar™ package configuration.
 - E. This package contains tin-lead (SnPb) balls. Refer to the 5 YZQ package (drawing 4205677) for lead-free balls.

NanoStar is a trademark of Texas Instruments.

IMPORTANT NOTICE

Texas Instruments Incorporated and its subsidiaries (TI) reserve the right to make corrections, modifications, enhancements, improvements, and other changes to its products and services at any time and to discontinue any product or service without notice. Customers should obtain the latest relevant information before placing orders and should verify that such information is current and complete. All products are sold subject to TI's terms and conditions of sale supplied at the time of order acknowledgment.

TI warrants performance of its hardware products to the specifications applicable at the time of sale in accordance with TI's standard warranty. Testing and other quality control techniques are used to the extent TI deems necessary to support this warranty. Except where mandated by government requirements, testing of all parameters of each product is not necessarily performed.

TI assumes no liability for applications assistance or customer product design. Customers are responsible for their products and applications using TI components. To minimize the risks associated with customer products and applications, customers should provide adequate design and operating safeguards.

TI does not warrant or represent that any license, either express or implied, is granted under any TI patent right, copyright, mask work right, or other TI intellectual property right relating to any combination, machine, or process in which TI products or services are used. Information published by TI regarding third-party products or services does not constitute a license from TI to use such products or services or a warranty or endorsement thereof. Use of such information may require a license from a third party under the patents or other intellectual property of the third party, or a license from TI under the patents or other intellectual property of TI.

Reproduction of information in TI data books or data sheets is permissible only if reproduction is without alteration and is accompanied by all associated warranties, conditions, limitations, and notices. Reproduction of this information with alteration is an unfair and deceptive business practice. TI is not responsible or liable for such altered documentation.

Resale of TI products or services with statements different from or beyond the parameters stated by TI for that product or service voids all express and any implied warranties for the associated TI product or service and is an unfair and deceptive business practice. TI is not responsible or liable for any such statements.

Following are URLs where you can obtain information on other Texas Instruments products and application solutions:

Products		Applications	
Amplifiers	amplifier.ti.com	Audio	www.ti.com/audio
Data Converters	dataconverter.ti.com	Automotive	www.ti.com/automotive
DSP	dsp.ti.com	Broadband	www.ti.com/broadband
Interface	interface.ti.com	Digital Control	www.ti.com/digitalcontrol
Logic	logic.ti.com	Military	www.ti.com/military
Power Mgmt	power.ti.com	Optical Networking	www.ti.com/opticalnetwork
Microcontrollers	microcontroller.ti.com	Security	www.ti.com/security
		Telephony	www.ti.com/telephony
		Video & Imaging	www.ti.com/video
		Wireless	www.ti.com/wireless

Mailing Address: Texas Instruments
Post Office Box 655303 Dallas, Texas 75265

Copyright © 2004, Texas Instruments Incorporated