



Shenzhen Yesok Electronics Power Co., Ltd.

Branch: HONGKONG YESOK ELECTRONICS POWER CO., LIMITED.

Add: A Building, Lian Tang Keng Industrial Park, Baotian 2nd Road, Xixiang, Baoan, Shenzhen Guangdong, China.

Tel: 86-755-61113030

Fax: 86-755-61113278

Email: sales@yyoss.cn

Website: www.yyoss.cn

www.yesokpower.com

www.yyoss.com.cn

100W Single output waterproof led driver (Constant Voltage Type)

YSV-100 Series

	Features
	1. 3 years warranty
	2. High efficiency 91%
	3. High reliability
	4. Economical design
	5. Protections: Short-circuit /Over-load /Over-voltage /Over-temperature / Lightning protection (Alternative)
	6. Working temperature : -40°C ~ + 70°C
	7. IP67 design
8. 2~3 times burn-in tests (+50°C/-40°C at full load with over 14 hours)	

Application

led strips, electronics display screen, outdoor instruments and machines..... etc

Specification Sheet

Model	YSV-100 Series	YSV-100-12	YSV-100-24	YSV-100-36	YSV-100-48	
Output	Rated Voltage (Note 1)	12VDC	24VDC	36VDC	48VDC	
	Output Current Range	0 ~ 8.33A	0 ~4.16A	0 ~ 2.77A	0 ~ 2.08A	
	Rated Power (Max)	100W	100W	100W	100W	
	Ripple and Noise (Max)(Note 2)	120mVp-p	150mVp-p	150mVp-p	180mVp-p	
	Voltage Tolerance	±3.0%	±3.0%	±2.0%	±2.0%	
	Line Regulation	±1%	±1%	±1%	±1%	
	Load Regulation	±1.0%	±1.0%	±1.0%	±1.0%	
	Set-up, Rise Time	1500ms 80ms/230VAC, 2000ms 80ms/110VAC				
Input	Hold-up Time	50ms/230VAC at full load, 25ms/110VAC at full load				
	Voltage Range	170~264VAC / 90~132VAC / 90~264VAC				
	Frequency Range	47~63Hz				
	Efficiency (Note 3)	86.0%	89.0%	91.0%	91.0%	
	AC Current	1.23A ~ 0.45A				
	Inrush Current	Cold Start at 70A/230VAC, Input at Ta: 25°C cold start.				
Protection	Leakage Current	< 0.5mA at 230VAC, 60Hz Input				
	Over-Voltage	110% ~ 130% (Shut down O/P voltage, repower on to recover)				
	Over-load	130% ~ 150% (Shut down O/P voltage, repower on to recover)				
	Short Circuit	Hiccup mode, recovers automatically after faulty problem is removed				
	Lightning Protection (Alternative)	Gas discharge tube automatically open to discharge, repower on to recover				
Environment	Over-temperature	85°C±10°C (Shut down O/P voltage, re-power on to recover)				
	Working Environment (Note 4)	-40°C ~ +70°C				
	Working Humidity	20~90% RH non-condensing				
	Storage Environment & Humidity	-40°C ~ +80°C				
	TEMP. Coefficient	±0.05%/°C (0~50°C)				
Safety & EMC	Vibration	10 ~ 500Hz, 2G 10min./1cycle, period for 60min. each along X, Y, Z axes				
	Safety Standards	EN-61347-1, EN61347-2-13, IP67, ROHS Tests, Design refer to UL8750				
	Withstand Voltage	I/P-O/P: 3KVAC, IP-FG:1.5KVAC, OP-FG: 500VAC				
	Isolation Resistance	I/P-O/P IP-FG OP-FG: 100M Ohms/500VDC / 25°C / 70% RH				
Others	EMC Emission	Compliance to EN55015: 2007, EN61547:1995+A1:2000; EN61000-3-2: 2006; EN61000-3-3: 2008				
	Life Span (Note 5)	≥50000Hrs (25~30°C)				
	No Load power consumption	≤1.5W				
	MTBF (Note 6)	250K hrs min, MIL-HDBK-217F (25°C)				
	Dimension (Note 7)	236*64*45 mm (L*W*H)				
Notes	Packing (Note 8)	15pcs/carton				
	Weight	1.1Kg/pcs				
	All parameter are measured at normal temperature (+25 ~ +28°C)					
1. The rated voltage can be customized, such as 18V/27V... can be customized						
2. Ripple & Noise are measured at 20KHz of bandwidth by using a 12" twisted pair-wire terminated with a 0.1 uf & 47uf parallel capacitor (at full load)						
3. The efficiency measured at Max output voltage, and 230VAC with full load, if with 110VAC the efficiency will be lowered 1% ~ 2%; Working 1~2 hours, efficiency will be higher 0.5% ~ 1% than the initial stage						
4. This series can work -45°C (at full load), if need related parameter contact us.						
5. This measured at 120VAC, 80% ~85% load with environmental temperature about +25°C~+30°C, the outer housing temperature with +55°C or so.						
6. This measured at 120VAC, 80% ~85% load with environmental temperature about +25°C~+30°C, the outer housing temperature with +55°C or so.						
7. More details see the following mechanical draft.						
8. The 15pcs packing method is not suitable for led drivers with waterproof connector						

Mechanical Specification

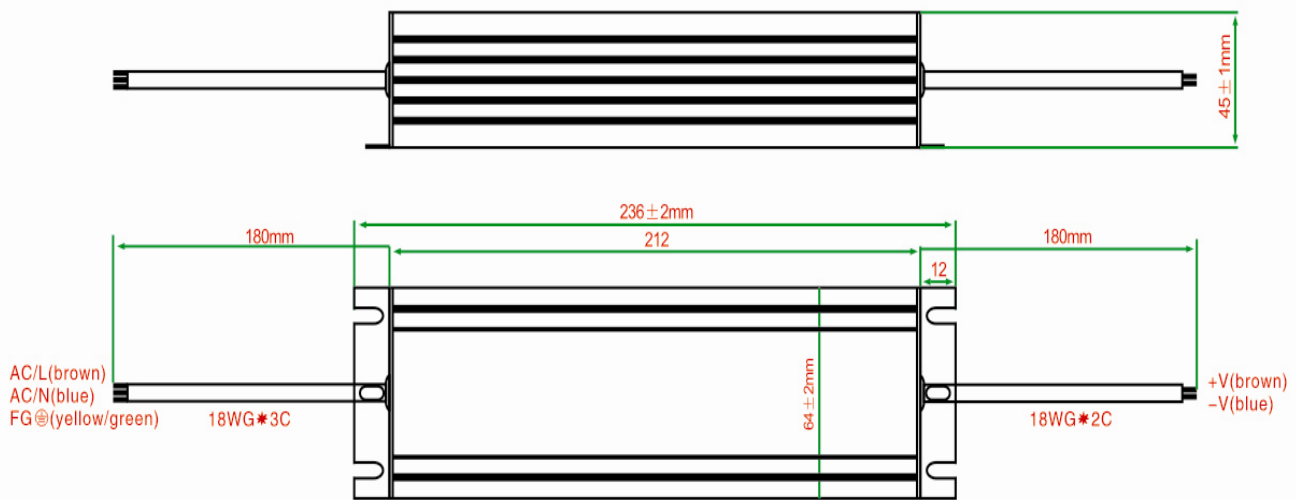

Block Diagram

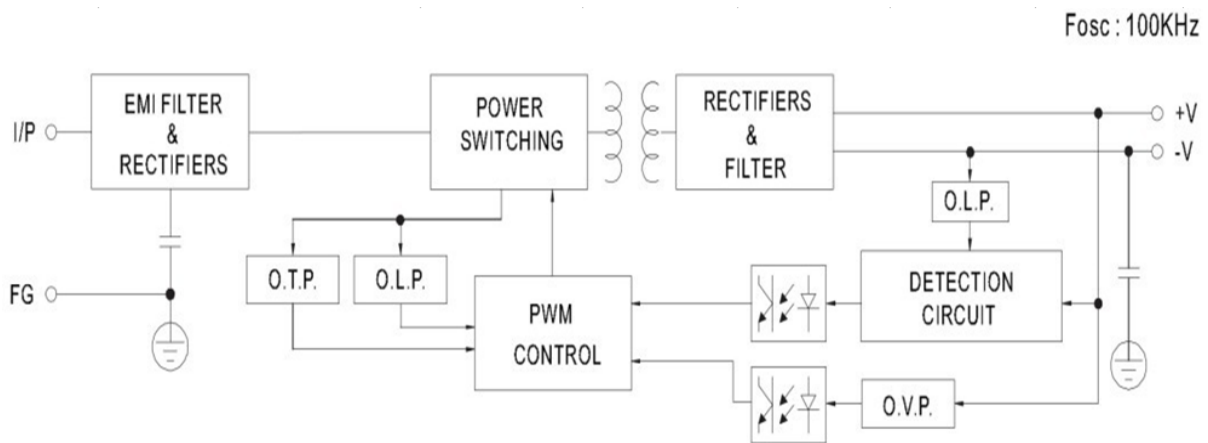

Derating Curve

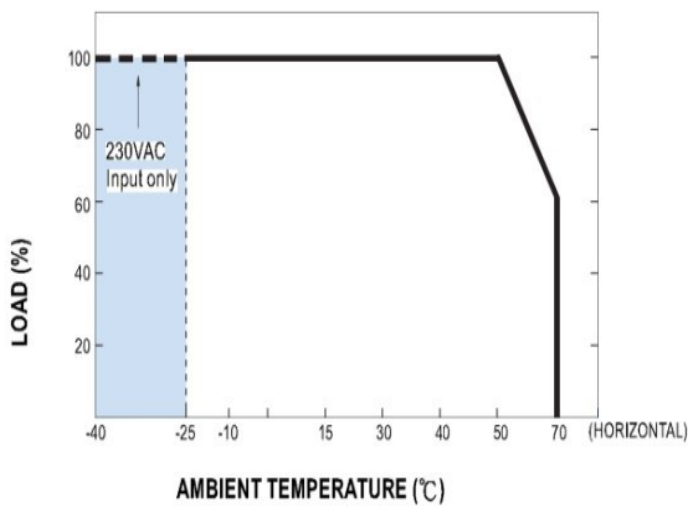

Static Characteristics

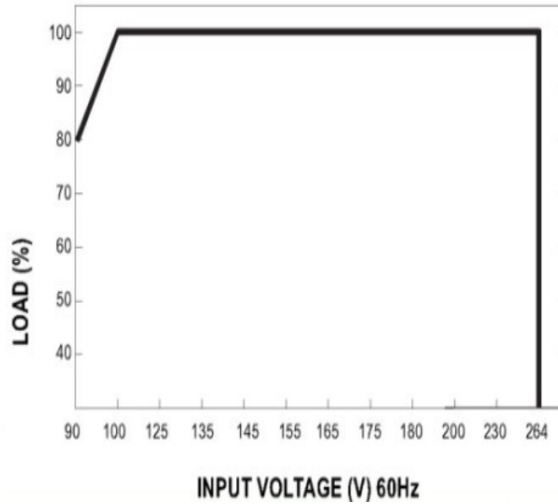

Efficiency & Load of (48V) (110VAC / 230VAC)

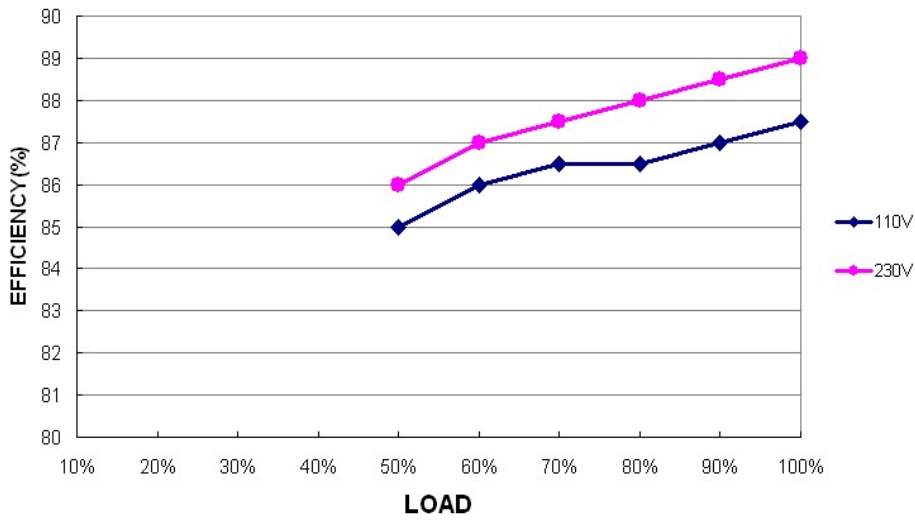

Waterproof connector (Alternative or customized)

The waterproof connector is usually used to easily assemble and replace in projects. It has waterproof performance when in use.

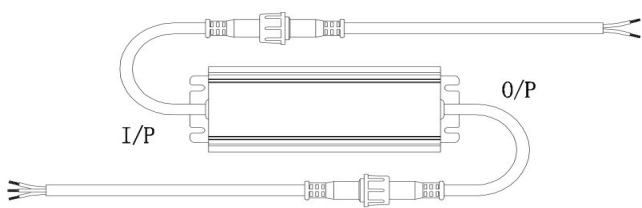

The type of connector can be customized or customer can independently buy in the market

